

Type	THERMOGLAZE Frozen Donut System
Model	TG25

THERMOGLAZE TG25

Frozen Donut System

Belshaw Adamatic's Thermoglaze TG25 is a system that thaws, heats, and glazes pre-fried, frozen donuts with results that equal (and often surpass) the quality of freshly made product.

- The TG25 can process all the varieties of frozen donuts currently available including ring donuts, fritters, long johns, cream and jam-filled donuts and many others. Thermoglaze is easy to operate, can be used in front of customers, and requires no ventilation hood.
- The TG25 processes approximately 24 dozen donuts per hour. Heating time and temperature can be modified to suit the product.
- The TG25 uses half-size 12½" X 17" glazing screens holding 12 typical donuts each.
- Donuts (or similar product) are thawed in the 8-shelf Thermolizer, located at the right of the machine, with adjustable temperature and humidity controls. Donuts can be held in the Thermolizer for up to 5 hours, enabling finished donuts to be produced on demand in under 5 minutes. After thawing/holding in the Thermolizer, the screens full of donuts are conveyed through the oven.
- Once heated in the oven, glaze is pumped up to a dispenser which coats each donut with a 1/8" thick curtain of glaze as they pass through.
- After glazing the screens can be placed on a cooling rack. On the opposite side to the Thermolizer, an additional 8-shelf storage (usable either for donuts, or screens) is provided.
- For iced donuts, the flow of glaze is turned off, and donuts can be iced on a Belshaw H&I-2 or H&I-4 icer.



Thermoglaze TG25. 8-shelf Thermolizer is shown at right (with door open). Storage shelves are shown at left.



TG25 top view



TG25 glazing donuts

90 Years of Quality Donut & Bakery Equipment

BELSHAW ADAMATIC BAKERY GROUP

814 44th St NW, Suite 103
Auburn, WA 98001 USA

PART OF ALI GROUP S.P.A.

CONTACT

800.578.2547 (USA/Canada)
(+1) 206.322.5474 Worldwide
info@belshaw.com

© 2015 Current version available at www.belshaw-adamatic.com

WEB

www.belshaw-adamatic.com

Type	THERMOGLAZE Frozen Donut System
Model	TG25

Thermoglaze TG25 Standard Features

- All stainless steel construction
- Capacity 24 dozen donuts/hour at thaw time of 20 minutes
- No ventilation hood or fire suppression system required. (Verify with local authorities)
- Heavy duty glaze pump
- Adjustable speed and temperature
- Quiet operation
- Glaze pump can be switched on/off as required
- Easy to clean oven interior
- Mobile with 4" (25mm) casters
- 8 shelves of storage space below for glaze, screens, etc
- Lock-out feature to prevent machine starting while cleaning is in progress
- ETL Certified, conforms to UL-197, CSA C22.2, and NSF-4

Integrated Thermolizer features

- 8 shelves. At 12 donuts per screen, the thermolizer holds 96 donuts at a time
- Capacity at thaw time of 20 min: 24 dozen donuts/hour
- Thermostat controlled dry heater for ambient warmth
- Thermostat controlled water element to produce steam
- Blower system for recirculating warm humid air
- 2 clear plexiglass doors
- Powered from central control box on TG25

CERTIFICATIONS



Certified by ETL to UL-197, UL-710B, NSF-4 and CSA C22.2 standards.

Screens

- TG25 uses 1/2-size glazing screens 12.5" x 17" (32 x 43 cm), Part #TJ-0001. 20-40 screens recommended

Electrical data (Requires two electrical connections)

Oven/Glazer

- Volts: 220V/60/1
- Amps: 28 A
- Kilowatts: 6.5 KW
- Plug: NEMA #6-50P
- Cord: 72" (1.8m)

Thermolizer

- Volts: 220V/60/1
- Amps: 10.5 A
- Kilowatts: 2.3 KW
- Plug: NEMA #6-20P
- Cord: 96" (2.4m)

Shipping Data

- Shipped on pallet
- Width: 73" (185 cm)
- Depth: 42" (107 cm)
- Height: 62" (158 cm)
- Volume: 110 cubic feet (3.12 cubic meters)
- Shipping weight: 649 lbs (295 kg)
- Freight class: 85

Optional accessory: H&I-2 or H&I-4 Icer



Water-warmed icing tables for applying icings to donuts warmed on the Thermoglaze system.

- H&I-2 Icer: Two 13" bowls
- H&I-4 Icer: Four 13" bowls
- H&I-2/4 info available at www.belshaw.com

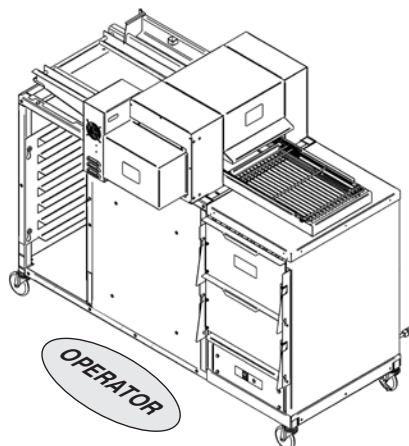
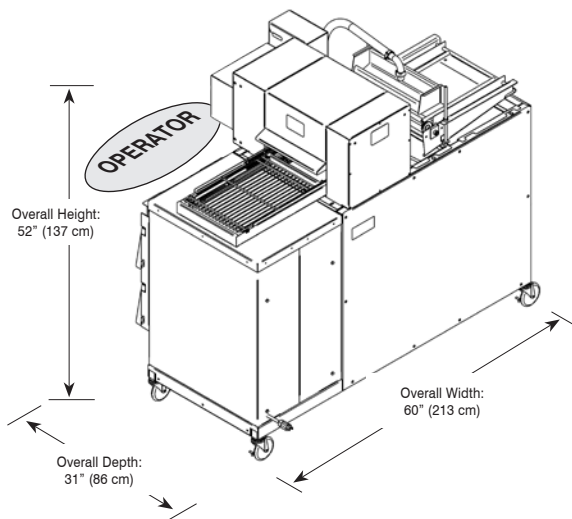

12.5" x 17" Screen for TG25

90 Years of Quality Donut & Bakery Equipment

BELSHAW ADAMATIC BAKERY GROUP

814 44th St NW, Suite 103
Auburn, WA 98001 USA

PART OF ALI GROUP S.P.A.

CONTACT

800.578.2547 (USA/Canada)
(+1) 206.322.5474 Worldwide
info@belshaw.com

© 2015 Current version available at www.belshaw-adamatic.com

WEB

www.belshaw-adamatic.com