



[www.monoequip.com](http://www.monoequip.com)

Enter **Serial No.** here. \_\_\_\_\_

In the event of an enquiry please quote this serial number.



## OPERATING AND MAINTENANCE MANUAL

# **MK2 DOUGH DIVIDER**

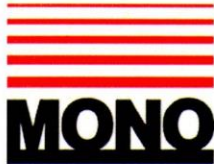

## DECLARATION OF CONFORMITY

We hereby declare that this machine complies with the essential health and safety requirements of :-

- The Machinery Directive 2006 / 42 / EC
- The Low voltage Directive 2006 / 95 / EC
- The requirements of the Electromagnetic Compatibility Directive 2004 / 108EC, 91 / 263 / EEC, 92 / 31 / EEC
- The General Safety of Machinery and food processing Standards applicable
- Materials and Articles intended to come into contact with food - Regulation (EC) No. 1935 / 2004
- Good manufacturing practice for Materials intended to come into contact with food - Regulation (EC) No. 2023 / 2006

<b>Signed</b>	
G.A. Williams – Quality Manager	

<b>Date</b>	
-------------	--

<b>Machine FG Code.</b>		<b>Machine Serial No.</b>	
-------------------------	--	---------------------------	--

A technical construction file for this machine is retained at the following address:

**MONO EQUIPMENT**  
Queensway,  
Swansea West Industrial Park,  
Swansea  
SA5 4EB  
UK

**MONO EQUIPMENT** is a business name of **AFE GROUP Ltd**  
Registered in England No.3872673 VAT registration No.923428136

Registered office: Unit 35,  
Bryggen Road,  
North Lynn Industrial Estate,  
Kings Lynn Norfolk,  
PE30 2HZ

**Failure to adhere to the cleaning and maintenance instructions detailed in this booklet could effect the warranty of this machine.**

□ **DISPOSAL**

**CARE SHOULD BE TAKEN WHEN THE MACHINE COMES TO THE END OF ITS WORKING LIFE. ALL PARTS SHOULD BE DISPOSED OF IN THE APPROPRIATE PLACE, EITHER BY RECYCLING OR OTHER MEANS OF DISPOSAL THAT COMPLIES WITH LOCAL REGULATIONS.**

(IN UK, ENVIRONMENTAL PROTECTION ACT 1990 APPLIES)

# CONTENTS

---

## 1.0 Introduction

## 2.0 General Dimensions

### 2.1 Dimensions

## 3.0 Specifications

## 4.0 Safety

## 5.0 Installation

## 6.0 Isolation

## DIVIDING MECHANISM CYCLE

## 7.0 Daily Cleaning Instructions

- Hopper Assembly
- Dividing Head Assembly
- Dividing Head Components
- Oil Collection
- Off Take

## 8.0 Weekly Cleaning Instructions

## DIVIDING MECHANISM CYCLE

## 9.0 Operating Machine

## 10.0 Setting and Machine Adjustments

- Adjusting Weight of Dough Pieces
- Dough Pieces of Less Than 450g.
- Adjusting Module Pressure

## 11.0 Maintenance

- Weekly
- Monthly
- “As Required”

## 12.0 Breakdowns

- Trouble Shooting

## 13.0 Spares and Service Information

- Spares Parts List

## 14.0 Electrical Information Section

- Electrical Diagrams

# 1.0 INTRODUCTION

MONO's MK2 Dough Divider is accurate, reliable and compact. It has a large capacity hopper, simple controls and adjustments.

The in-line discharge gives a very compact machine. This is of particular benefit in small bakeries, or where the divider is to be used with an automatic bread plant.

The dough divider has the capacity to accurately scale 1000 dough pieces every hour, between 10oz (284g) and 50 oz (1400g).

# 2.0 GENERAL DIMENSIONS

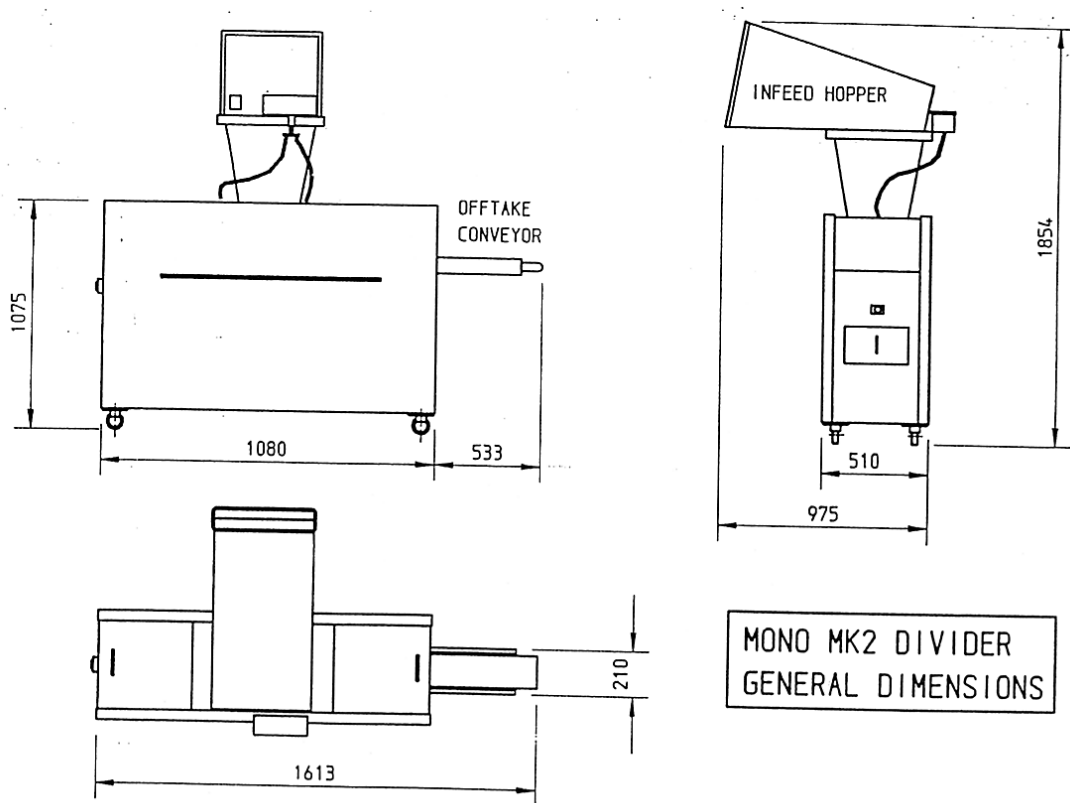

# 2.1 DIMENSIONS

Height: 1854mm (73").  
Depth: 1613mm (63 1/2").  
Width: 585mm (23").

## 3.0 SPECIFICATIONS

---

**Total power:** 0.78kW; single or, three phase.

**Capacity:** Up to 1000 accurately scaled dough pieces every hour, between 284g and 1400g (10oz - 50oz).

**Weight:** 465kg.

**Noise Level:** Less than 85dB.

## 4.0 SAFETY

---

- 1 Never use a machine in a faulty condition and always report damage.
- 2 **No one under 16 may operate** this machine.
- 3 **No one under 18 may clean** this machine under any circumstances.
- 4 Only trained authorised persons may remove any part from this machine that requires a tool to do so.
- 5 Always ensure hands are dry before touching any electrical appliance (including cable and plug).
- 6 All operatives must be fully trained.
- 7 People undergoing training on the machine must be under direct supervision of Trainer.
8. Do not operate with any panels removed.
- 9 All guards must be fixed in place with bolts or screws unless protected by a safety switch.
- 10 The bar (1) at the opening of the swan neck canopy (2) must not be removed.

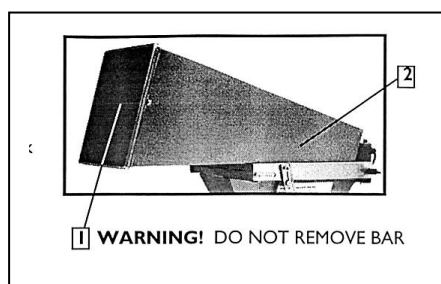

11. No loose clothing or jewellery to be worn while operating machine.
- 12 Switch off power at the mains isolator switch when machine is not in use and before carrying out cleaning or maintenance checks.
- 13 The Bakery Manager or Supervisor must carry out daily safety checks.

**14**    **WARNING:**  
NEVER LEAVE MACHINE WITH DOUGH IN SUCTION CHAMBER  
AS DANGEROUS PRESSURES BUILD UP AS THE DOUGH PROVES.

**15**    **WARNING:**  
**NEVER PUT YOUR HAND INTO THE SUCTION CHAMBER.** EVEN WITH  
THE MACHINE EMPTY AND DISCONNECTED FROM THE MAINS SUPPLY,  
THE HIGH LOADING OF THE COMPRESSION SPRING COULD PROPEL  
THE SUCTION PISTON WITHOUT WARNING AND CAUSE SERIOUS  
PERSONAL INJURY.  
NEVER PUT YOUR HAND INTO THE SUCTION CHAMBER, EVEN WITH  
PISTON REMOVED, AS THERE IS A DANGER OF INJURY IF BACKSLIDE  
(34), OR SUCTION PISTON (29) MOVES.

**16**    **WARNING!** ONLY CLEAN INTERIOR OF SUCTION CHAMBER WITH  
TRIANGULAR SCRAPER (3). PAY PARTICULAR ATTENTION TO TOP OF  
CHAMBER WHERE KNIFE BEARS.

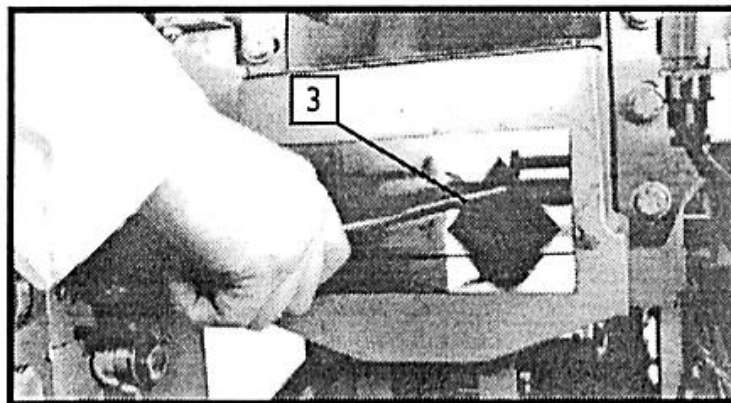

**17**    Any internal maintenance must be carried out by fully trained maintenance  
personnel only.



## 5.0 INSTALLATION

---

- 1 The MK2 Dough Divider should be connected to a wall isolator.
- 2 Check machine after installation to ensure conveyor belt travels in the direction indicated (see arrow). This should be done by 'inching' the motor. If motor rotation is incorrect transpose any two of the three phase carrying wires.

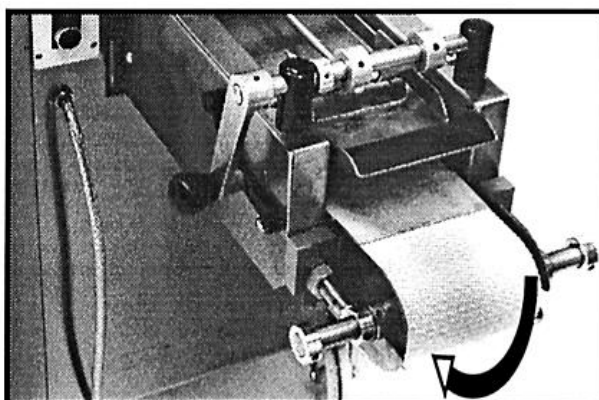

- 3 Before use **MONO** dough dividers are delivered with a protective coating of grease on the dividing head components. This should be removed before use by following the 'daily' cleaning procedure see 7.0
- 4 Ensure machine is standing on a solid floor and is level. Fill oil tank with your company recommended food safe oil and lubricate machine through all grease points. (Recommended grease **Lithium EP2**, high temperature, multi purpose grease).
- 5 The divider should be used on a level floor for best results

## 6.0 ISOLATION

---

**To stop the dough divider in an emergency, switch off at the wall isolator, or the machine's emergency stop button (4).**

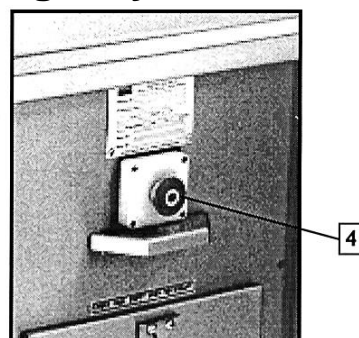

# DIVIDING MECHANISM CYCLE

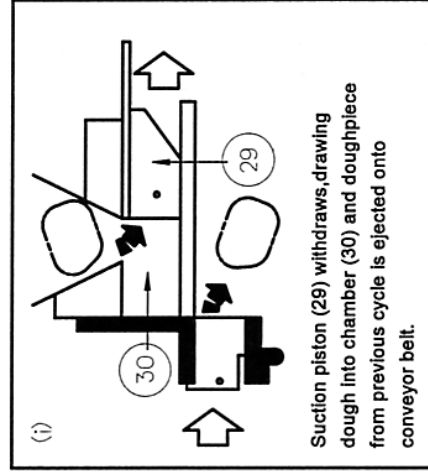
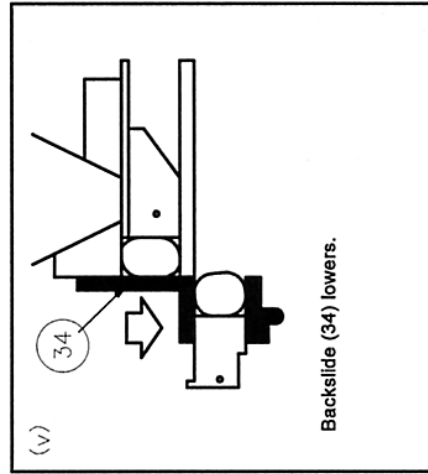
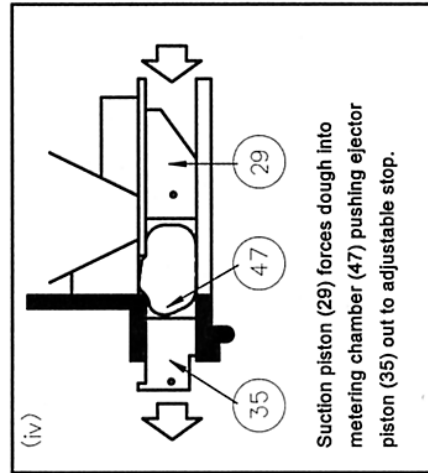
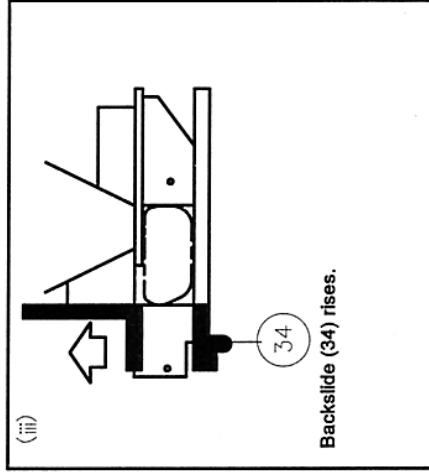
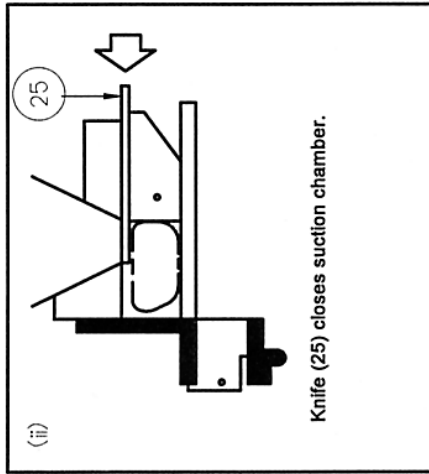
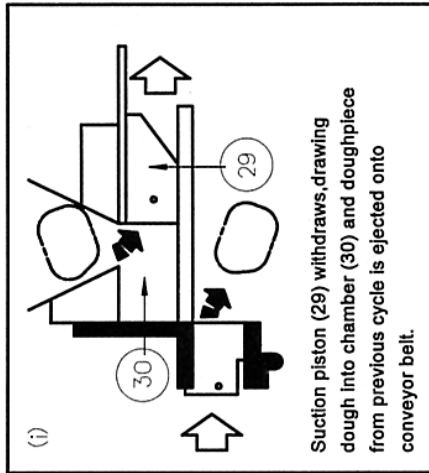

# **7.0 DAILY CLEANING INSTRUCTIONS**

## □ **Hopper Assembly.**

**NOTE:**

**ISOLATE MACHINE FROM MAINS SUPPLY BEFORE CLEANING.**

- 1 Remove dough residue from interior of canopy (2) (using a plastic scraper).
- 2 Gain access to hopper (5).
- 3 Remove dough residue as above.
- 4 Using triangular shaped scraper supplied, scrape cast metal chamber inside hopper.
- 5 Smear (spray) interior of hopper (5) with divider oil.
- 6 Close and secure canopy (2).

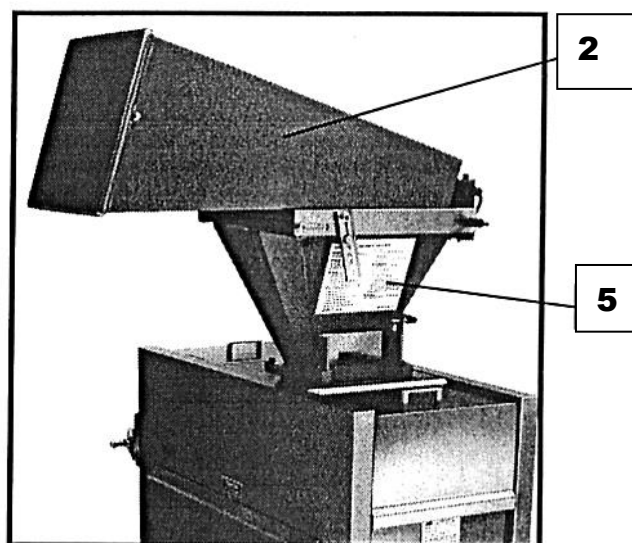

## DIVIDING HEAD ASSEMBLY

**Note:** The dividing head components are machined to extremely fine tolerances and the greatest possible care must be taken to ensure these parts are not knocked, scratched or damaged.

### 1 SWITCH ON ISOLATOR.

Start machine briefly and "inch" machine using inching button (6) until knife and piston are fully withdrawn (position (i) of dividing cycle) then stop and isolate machine from mains supply.

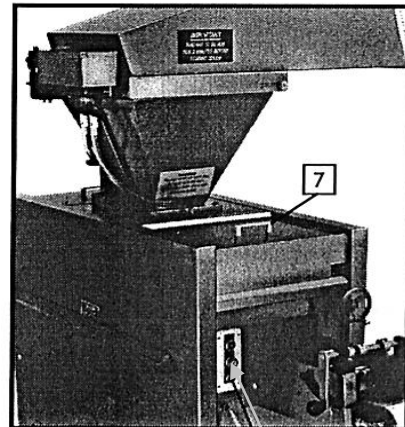
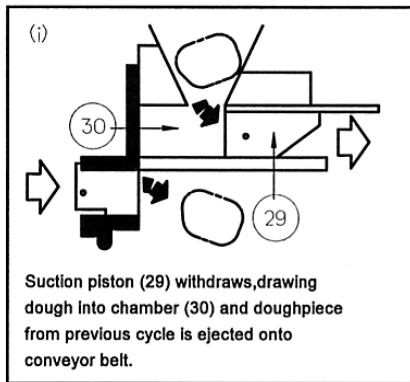

INCH BUTTON (6)

### **WARNING:**

**Internal parts can still move causing injury, even if machine is turned off and isolated.**

### 2 Lift off cover (7).

### 3 Withdraw locking pin (8) and remove actuating pin (9).

### 4 Remove knife (25).

### 5 Place knife on clean surface, scrape down across the faces using plastic scraper and wipe off all foreign matter.

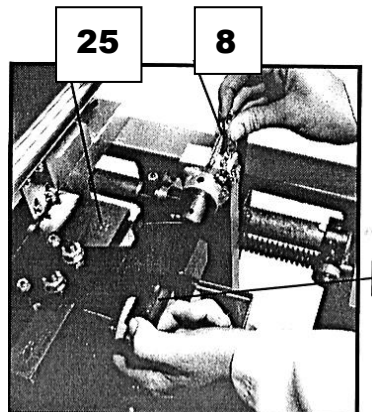

9

## **DIVIDER HEAD COMPONENTS**

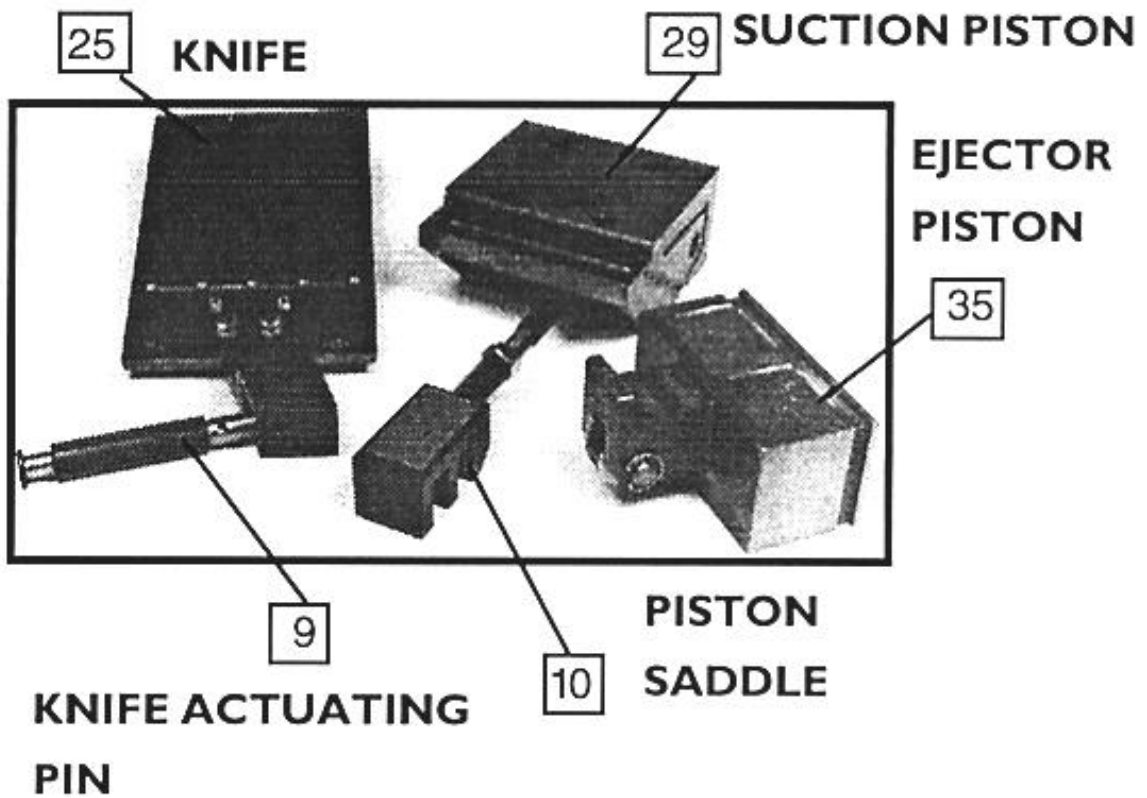

**THESE ARE PRECISION MADE ITEMS  
HANDLE WITH CARE**

6 IF REQUIRED CLEAN COMPONENTS WITH **SOAP AND WATER** .  
**DRY IMMEDIATELY AND SMEAR WITH DIVIDER OIL TO PREVENT CORROSION.**

7 Lift piston saddle (10).

8 Push suction piston (29) in slightly to clear activating pin (11).

9 Lift saddle and remove suction piston, place on clean surface and clean as described in 5/6.

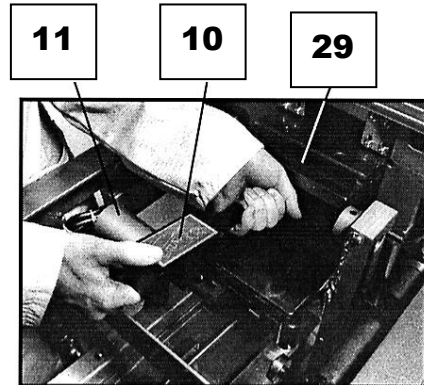

10 **NOTE:** CLEAN INTERIOR OF SUCTION CHAMBER (30) WITH TRIANGULAR SCRAPER (3) PROVIDED; PAYING PARTICULAR ATTENTION TO TOP SURFACE WHERE KNIFE BEARS (SEE SAFETY INSTRUCTIONS).

**WARNING! NEVER PUT YOUR HAND INTO CHAMBER**

11 Wipe all components clean with tissue and smear components with divider oil.

12 Insert suction piston (29); lift piston linkage; pull back piston to appropriate notch (see setting instructions) and lower onto activating pin (11).

13 Slide in knife blade (25) ensuring surface marked "Top" is uppermost.

14 Re-fit knife blade actuating pin (9) and locking pin (8).

15 Re-fit cover (7).

SWITCH ON ISOLATOR.

16 Operate machine with aid of inching button (6) until backslide (34) is at the top of its stroke.

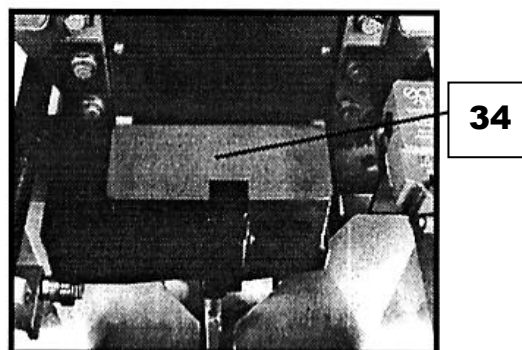

**ISOLATE MACHINE FROM MAINS SUPPLY.**

- 17 Lift off cover (12).

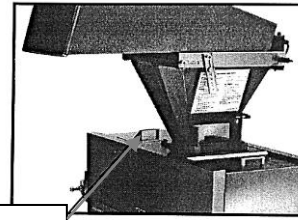

12

- 18 Raise ejector piston actuating arm (13) and lock into retaining slot (14).

13

- 19 Withdraw ejector piston (35). Place on a clean table and clean as detailed in instruction 5.

- 20 Clean exterior surfaces of backslide.

- 21 Lift out guard plate (15) and clean beneath.

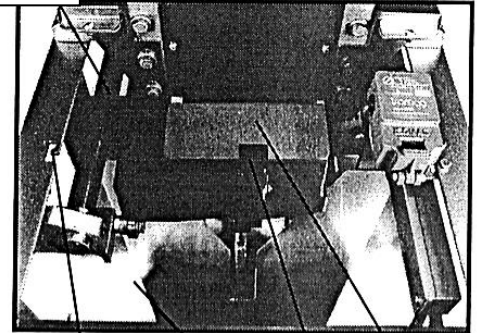

14

16

35

15

- 22 Wipe down guard sheet (16)

- 23 Re-assemble in reverse order to instructions 17 to 21. Lubricate with divider oil prior to re-assembly.

**SWITCH ON ISOLATOR.**

- 24 "Inch" machine carefully through cycle then stop machine at position (iv) of dividing cycle.

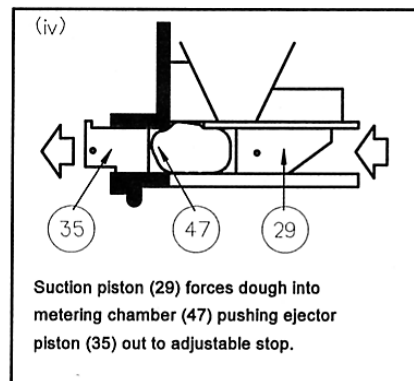

**NOTE:**

The above steps must be followed daily otherwise it will lead to the build up of starch and seizure of the machine.

□ **Oil Collection**

- 1 Withdraw oil collection tank (17) and empty contents.
- 2 Refit oil collection tank.
- 3 Withdraw drip tray (18) and empty contents.
- 4 Refit drip tray.

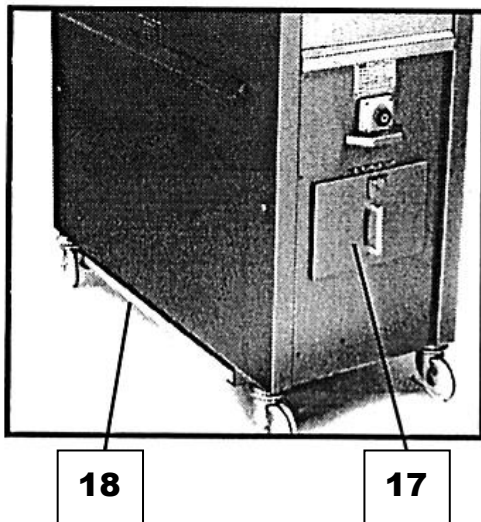



□ **Off take**

**ISOLATE MACHINE FROM MAINS SUPPLY.**

- 1 Raise pressure board (19) with adjusting handle (20).
- 2 Unlatch clip (21).
- 3 Slide pressure board towards divider to release then withdraw.
- 4 Scrape and wipe pressure board with a clean cloth.
- 5 Scrape and wipe down belt.
- 6 Remove dough residue from conveyor bright work and belt surface.
- 7 Re-connect mains supply. Replace covers (7) & (12), and using inching button (6), cycle machine until unclean area of conveyor is in view.
- 8 Isolate machine from mains supply.
- 9 Repeat steps 10.5 to 10.8 as necessary.
- 10 Re-assemble machine.

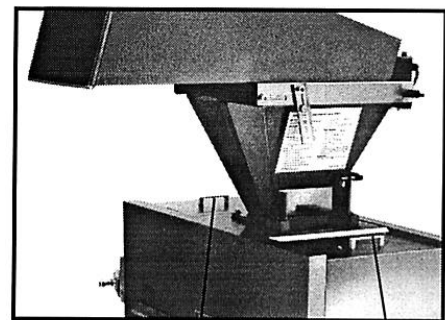
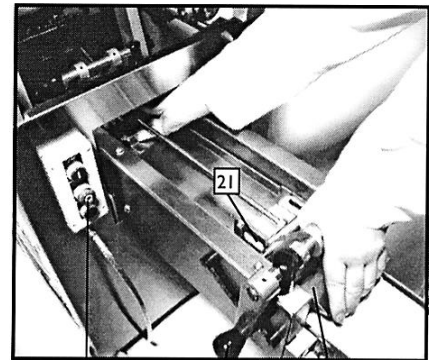

□ **External Cleaning**

- 1 Brush off flour residue and scrape as necessary.
- 2 Brush off loosened dough.
- 3 Make up solution of sterilising solution and hot water.
- 4 Spot clean exterior of machine as necessary working from top to bottom.
- 5 Swab dry with tissue.

# 8.0 WEEKLY CLEANING INSTRUCTIONS

**WARNING:**

Internal parts can still move causing injury, even if machine is turned off and isolated.

**WARNING:**

CLEANING SHOULD ONLY BE CARRIED OUT BY FULLY TRAINED PERSONNEL

**NOTE:**

ISOLATE MACHINE FROM MAINS SUPPLY

- 1 Remove four screws (22), two each side.
- 2 Remove side sheets (23) and (24).
- 3 Remove top covers (7) and (12).
- 4 Remove, clean and refit suction piston drip tray (26).
- 5 Remove, clean and refit guard sheet (27).
- 6 Clean out oil way (28) and wipe down all interior bright work.
- 7 Brush down interior framework with nylon bench brush.
8. Clean down interior framework with a solution of hot water and sterilising solution, taking care not to get excessive water into the machine. Take special care around the motor and housing.
9. Scrub wheels with small nylon cleaning brush or scouring pad and hot water sterilising solution.
- 10 Refit side sheets, covers and screws.
- 11 Clean entire exterior surfaces of the machine working from top to bottom.
- 12 Remove and clean oil collection tank (17) and drip tray (18).

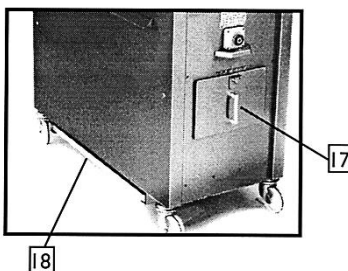
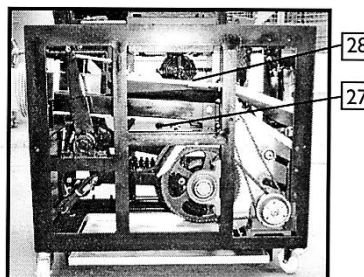
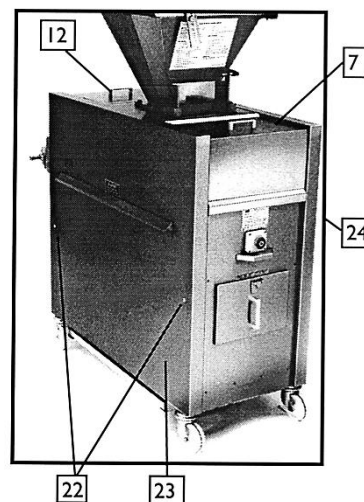

# DIVIDING MECHANISM CYCLE

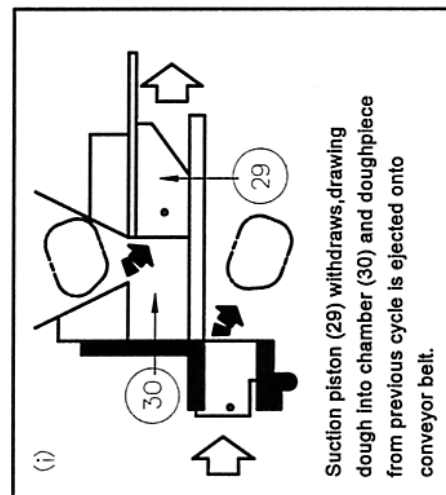
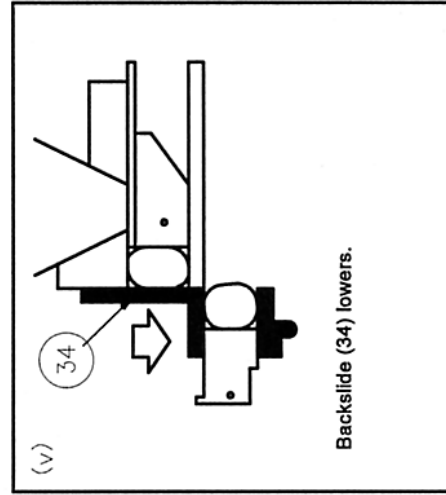
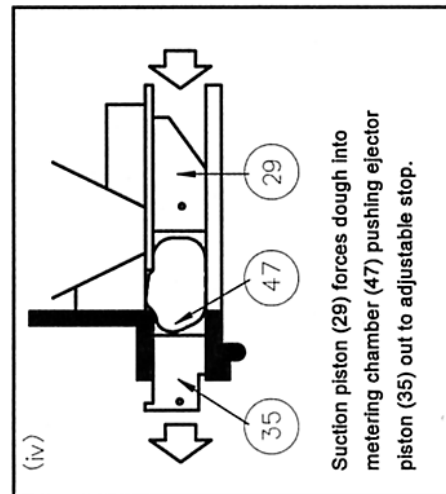
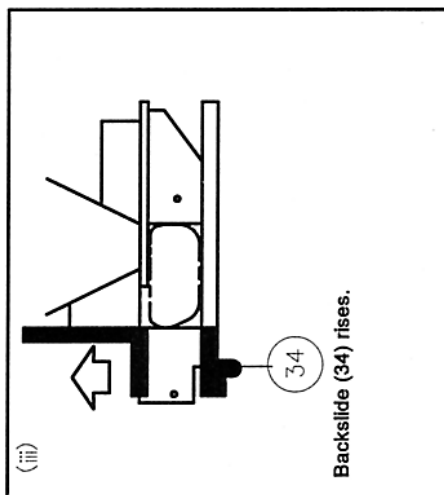
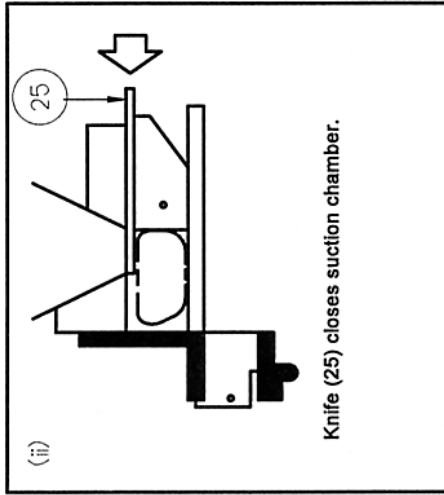
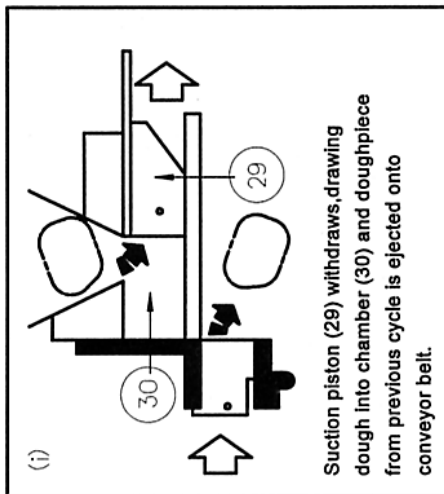

## 9.0 Operating

---

**(If not familiar with machine, refer to 10.0 for adjustment information prior to starting).**

- 1 Check isolator is switched on at wall (and intermediate prover control panel).
- 2 Open canopy (2) by loosening knob (33) and sliding canopy away from magnetic switch (36) to allow canopy to tilt open.
- 3 Smear interior of hopper (5) with divider oil.
- 4 Close and secure canopy (2).
- 5 Smear interior of canopy (2) with divider oil.

**WARNING!** DO NOT USE VEGETABLE OIL FROM SHOP FLOOR, AS IT WILL FORM A GUM LIKE RESIDUE, CAUSING STICKING AND POSSIBLE DAMAGE TO THE MACHINE. MONO RECOMMENDS THE USE OF ECONO DIVIDER OIL.

**NOTE:**

Approved Econo Divider Oil is vegetable based but formulated to prevent gum deposits.

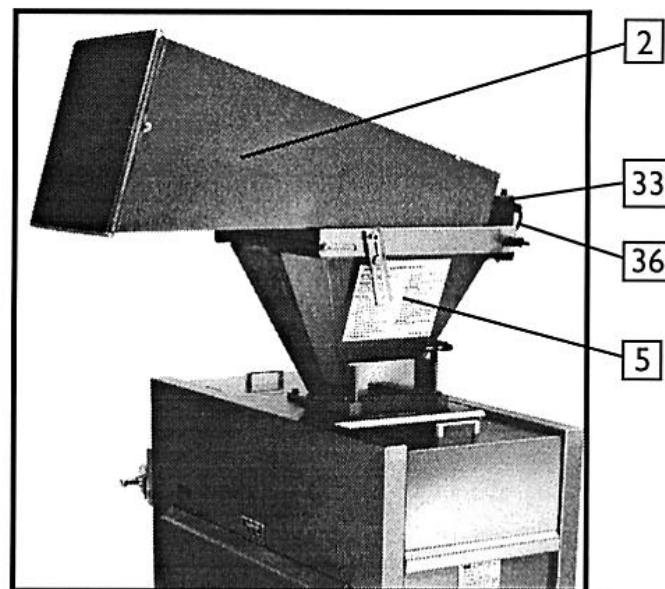

6 **Start machine** by using start button (37)

**NOTE:** On dividers connected to new type bread plants the divider will start only if the infeed button on the intermediate prover control panel has been pressed.

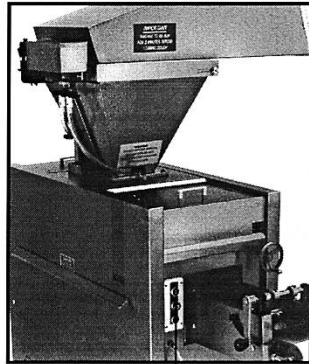

37

7 Regulate drip feed to **30 drops per minute** at each regulation valve (38).

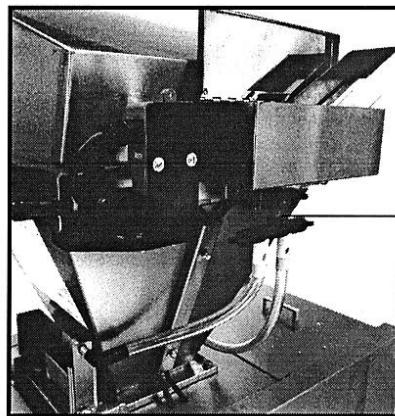

38

8 Run machine for two minutes to allow oil to circulate.  
**Then Stop Machine**

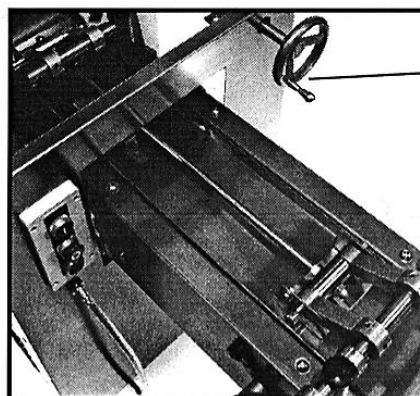

39

9 Set machine weight control adjustment hand wheel (39) to required "guide" setting (see section 10.0).

- 10 Load dough into hopper.
- 11 Run the machine and check first dough pieces out of discharge conveyor for weight and cleanliness. Normally the first six dough pieces are put back into the hopper as weight consistency is normally suspect in the initial dough pieces. If any dough pieces are contaminated with excess oil or traces of previous doughs eg. Wholemeal, discard accordingly.

**Note:** It is advisable to thoroughly check hopper - divider head - and offtake conveyor for traces of previous doughs to prevent contamination.

- 12 Adjust for weight of dough piece required (refer to Setting and Machine Adjustments, section 10.0).
- 13 Adjust moulding pressure as required,(refer to Setting and Machine Adjustments, section 10.0).
- 14 Check oil level in tank (40) frequently throughout shift and top up, if required.

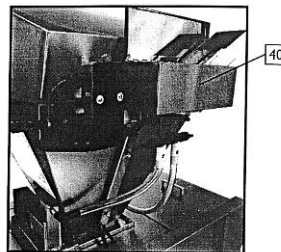

- 15 Run dough through divider. Care must be taken with weights especially towards end of dough.

**Note:-** The divider is a volume divider which divides by size of dough piece, not by weight. **Be aware that dough is a “live” product and will expand in size during the dividing process.**

- 16 After use, stop machine in position “iv” of dividing cycle to conserve oil on suction piston and knife.

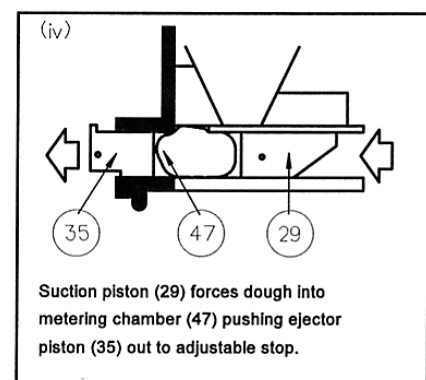

**WARNING!** NEVER LEAVE MACHINE WITH DOUGH IN SUCTION CHAMBER, AS DANGEROUS PRESSURES CAN BUILD UP AS THE DOUGH PROVES

# 10.0 SETTING AND ADJUSTMENTS

## □ Adjusting weight of dough pieces

- 1 Run Machine.
- 2 Weigh divided dough pieces.
- 3 Turn adjustment wheel (39) clockwise to decrease weight, anti-clockwise to increase weight. As a guide, settings between 3-5 are suitable for 400g weight dough pieces and 7-9 of 900g weight range dough pieces.

**Remember this machine divides by volume not weight.  
Settings will vary due to condition of dough.**

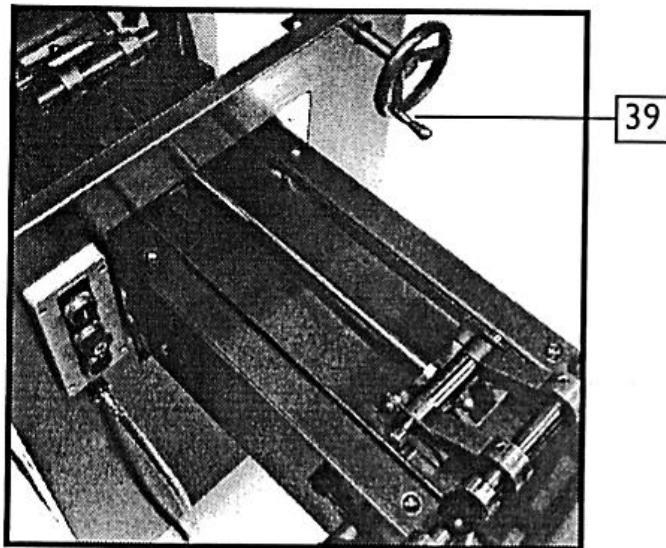

- 4 Weigh following dough pieces and re-adjust if necessary.

□ **Dough Pieces of less than 450g.**

Normally, actuating pin (11) should be located in saddle notch (1lb+) 450g. However, when producing dough pieces of less than 1lb (450g) weight it is preferable to change the notch setting to avoid excessive pressure being put on the dough:

**To change notch:**

- 1 Cycle machine to position 'i' of dividing cycle.

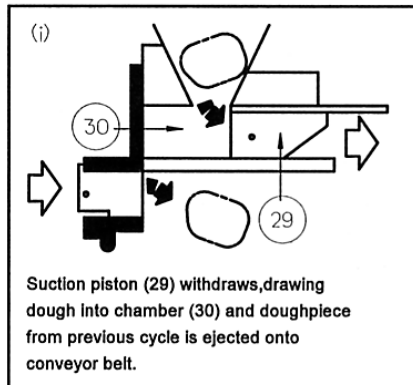

- 2 Lift cover (7).

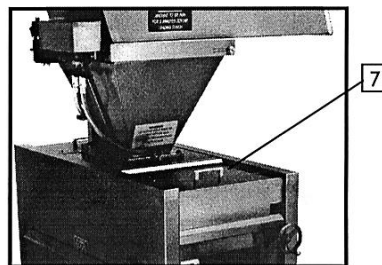

- 3 Withdraw locking pin (8) and remove actuating pin (9) from knife arm (41).

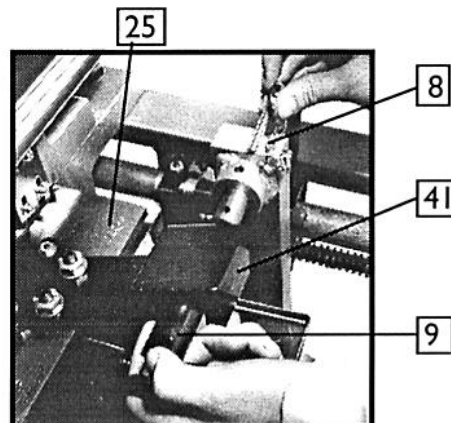

- 4 Remove knife (25).



- 5 Lift saddle (22), pull back piston, and lower saddle notch (11b-) onto suction piston actuating pin (9).

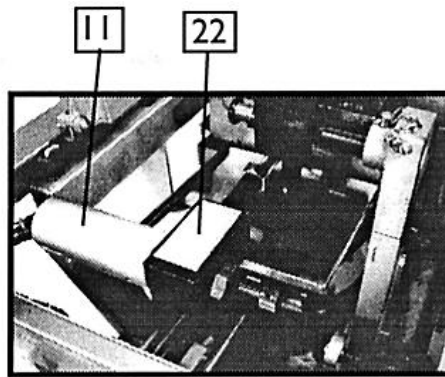

- 6 Refit knife (25).
- 7 Refit cover (7).

---

□ **ADJUSTING MOULDING PRESSURE**

Offtake pressure board (19) may be raised or lowered by means of adjusting handle (20) with spring loaded plunger. As a guideline, the second detent from the top is generally suitable for 900g range dough pieces and the fourth from the top for 450g range dough pieces.

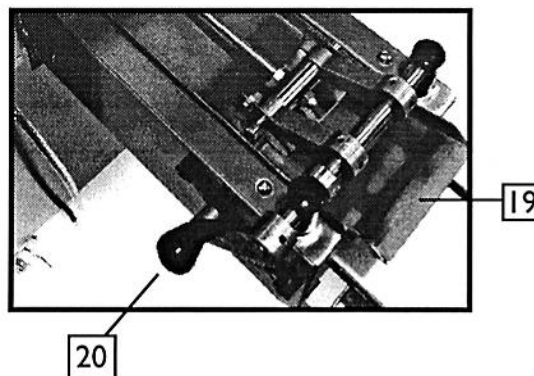

**NOTE:** When used with intermediate prover the pressure board must be set correctly or prover infeed system may malfunction causing loss of dough.

# 11.0 MAINTENANCE

## □ WEEKLY MAINTENANCE

1 ISOLATE MACHINE FROM MAINS SUPPLY.

2 Apply grease to main piston sheave grease nipple (42).

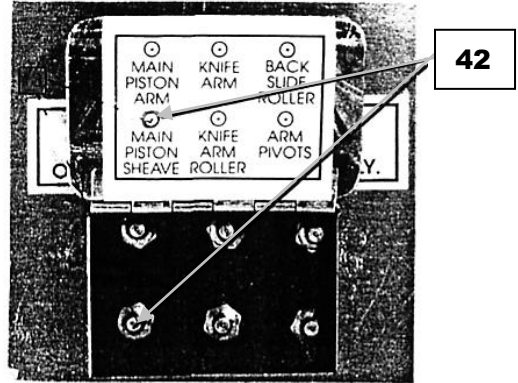
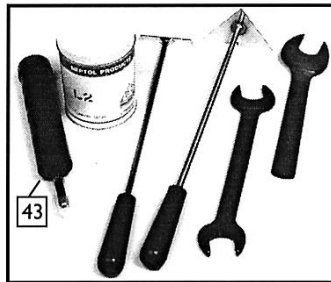

**Note:** Nipple located in cluster of six on side or end of divider. Use correct grease gun (43) normally one pump will suffice. **DO NOT use large grease gun** from oven as this could cause pipes to burst.

3 Re-connect electrical supply.

## □ MONTHLY MAINTENANCE

1 Remove two screws (44).

2 Remove backslide oil retaining shield (45), clean and refit.

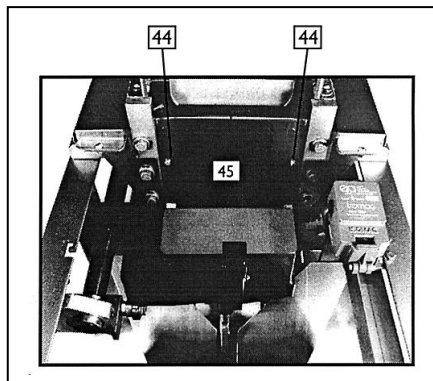

3 Refit screws.

4 Apply grease to six grease nipples, using correct grease gun (43), Lithium L2 high temperature grease.

## □ **"AS REQUIRED" MAINTENANCE**

### ○ **Conveyor Belt Adjustment**

Conveyor belt should be no tighter than necessary to eliminate slippage. Over tensioning can lead to belt and/or bearing failure. The belt should be adjusted by means of tensioning nuts (46).

The belt should run with equal clearance between its edges and the conveyor unit side frames. If one edge of the belt is tighter than the other, it will tend to run towards the slack side. This tracking defect can be eliminated by individual adjustment of the tensioning nuts.

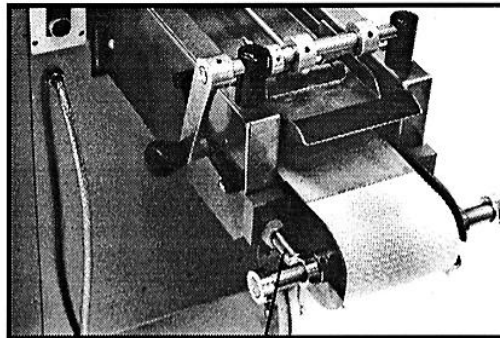

46

---

### ○ **SLIPPING CLUTCH**

The motor drive sprocket is fitted with a slipping clutch. This is provided so that if a foreign object causes the machine to jam the clutch will "slip" preventing damage to the machine.

When the "slipping" clutch is brought into operation, the offtake conveyor continues to rotate leaving the action of the machine stationary.

# 12.0 BREAKDOWNS

---

FOR IMMEDIATE ACTION Refer to this TROUBLE SHOOTING SECTION

If machine is still not operating call out **MONO** service dept.

## □ TRUBLE SHOOTING

### ○ **Divider does not run**

- 1 Check power turned on at isolator on wall (and intermediate prover).
- 2 Check plug into intermediate prover is correctly connected if used with this machine.
- 3 Check machine is switched on and stop button (4) is not depressed. (Turn to release.)
- 4 Check safety switches are correctly located on covers (7 and 12) and hopper hood (48).

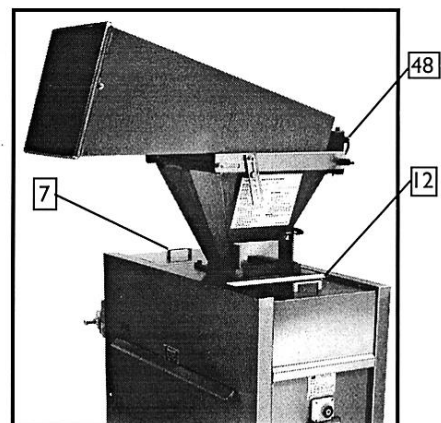
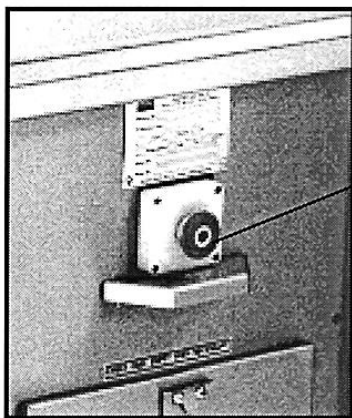

**NOTE:** NEW TYPE BREAD PLANT ONLY.

Check infeed button on intermediate prover control panel has been pressed.

**WARNING: IF THERE IS ANY POSSIBILITY OF DAMAGE TO PLUG OR LEAD, ISOLATE DIVIDER AT WALL ISOLATOR BEFORE CHECKING.**

If divider still will not function after carrying out these checks call out Miller's service dept.

- **Discharge conveyor turns but main machinery does not rotate.**

**ISOLATE MACHINE FROM MAINS SUPPLY.**

**CHECK THE FOLLOWING:**

1. Check slipping clutch.

**NOTE:** *IF SLIPPING CLUTCH HAS OPERATED, IT MEANS THAT THE DIVIDER MOTOR HAS BEEN OVERLOADED DUE TO JAMMING OF THE DIVIDING HEAD MACHINERY.*

2. Check Machine has oil in divider head and in tank.
3. Check oil drip feed is turned on
4. Open hopper canopy. Check in Hopper (5) for any object that could be jamming machine. **If a foreign object is jammed** in divider components: Call out **MONO** service contractor.

**DO NOT ATTEMPT TO REMOVE IT, AS THE COMPONENTS MAY BE UNDER TENSION. RELEASING THE OBJECT MAY CAUSE COMPONENTS TO MOVE, TRAPPING THE OPERATOR'S HAND.**

- 5 Check machine is in a CLEAN condition.

**NOTE:** IF MACHINE HAS NOT BEEN CLEANED FROM PREVIOUS DAY, DOUGH WILL "SET" AND THE FORCE REQUIRED TO MOVE DIVIDING MACHINERY WILL OVERLOAD MOTOR, OPERATING THE SLIPPING CLUTCH.

- 6 If the above has happened: Care must be taken when removing the components as it is possible they are under pressure caused by expansion of the dough.
- 7 Take special care with ejector piston (35), as moving ejector piston actuating arm (36) will release the ejector piston, which if under pressure will be propelled outwards and could cause serious injury.

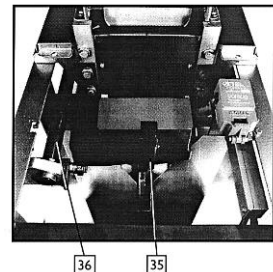

- 8 Thoroughly clean divider, visually checking parts for damage and distortion.
- 9 Oil parts.
- 10 Re-assemble.
- 11 If problem persists call **Miller's** service dept.

## **13.0 SPARES AND SERVICE**

---

If a fault arises, please do not hesitate to contact the Customer Service Department, quoting the **machine serial number** on the silver information plate of the machine and on the front cover of this manual

### **SERVICE:**

**MONO**  
Queensway  
Swansea West Industrial Estate  
Swansea. SA5 4EB UK

**email: [spares@monoequip.com](mailto:spares@monoequip.com)**  
**Web site: [www.monoequip.com](http://www.monoequip.com)**

**Tel. 01792 561234**  
**Fax. 01792 561016**

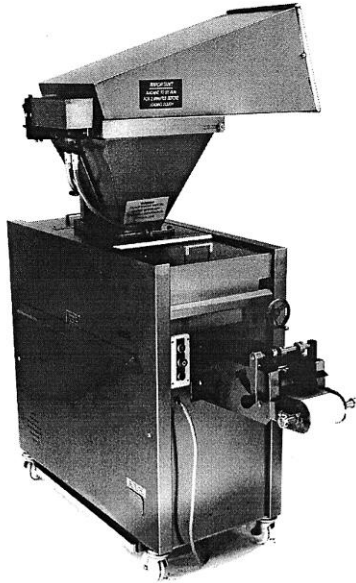

## SPARE PARTS LISTS

**ONLY TRAINED PERSONNEL TO PERFORM  
MAINTENANCE ON THIS MACHINE**

**SHEET A****MONO DIVIDER MK2 MAIN SPARES LIST**

<b>ITEM</b>	<b>PHOTO/SHEET NO</b>	<b>DESCRIPTION</b>	<b>PART NO</b>
1	5	OIL FEED SOLENOID 240v 50Hz	B867-83-002
	5	OIL FEED SOLENOID 220v 60Hz	B867-83-005
2	5	OIL TANK ASSEMBLY	038K11DO2002
3	5	OIL VALVE KIT	038-11-02800 A900-34-011 A900-05-081
4	4	PRESSURE BOARD ADJUSTING HANDLE	038-10D02800 038-10D02900 A900-19-048 P700-07-010
5	4	ROLLER SHAFT	038K10D00600
6	5	SAFETY SWITCH (SWITCH & MAGNET) SAFETY SWITCH (MAGNET ONLY)	B818-07-001 B818-45-001
7	7,6	SHEAVE UNIT	038K04D00000
8	1	STOP BUTTON	B809-98-004
9	2	SPROCKET 76 TEETH	038-03D00900
10	7	SLIPPING CLUTCH (TORQUE LIMITER)	038-03D08500
11	7	TRANSFORMER	B849-31-001
12	5	WINGNUT	P700-04-017
13	7	BACKSIDE CAM FOLLOWER	006K0P02800
14	4	BELT ADJUSTER	038-10D00500
15	1	EJECTOR PISTON	006KSX010
16	6	FAN	B869-75-001
17	7	FREEWHEEL SPROCKET	038-03-01900
18	7,4	CURLING BELT	A900-22-047
19	7,4	CONVEYOR BELT	A900-22-045
20	7,4	HANDWHEEL	038-09D03200
21	5	OIL FEED PIPES	A900-23-003
22	2	JOCKEY ASSEMBLY (CONVEYOR DRIVE)	038-03D08900
23	2	JOCKEY ASSEMBLY (MAIN DRIVE)	038-03P12200



**SHEET B****MONO DIVIDER MK2 MAIN SPARES LIST**

<b>ITEM</b>	<b>PHOTO/SHEET NO</b>	<b>DESCRIPTION</b>	<b>PART NO</b>
27	7	HOPPER GASKET	038-11D02600
28	1	MAIN PISTON	038-05D00400
29	3	MAIN PISTON CON-ROD	038-05D02400
30	3	MAIN PISTON SADDLE	038-05D02500
31	1	MAIN PISTON SHIM	038K05D00900
32	7	MAIN CAM	038K03D01000
33	6	MOTOR/GEARBOX	B909-74-001
34	4	NYLON ROLLER	038-10-05000
35	6	BACK SLIDE ARM	038-08D00700
36	3	CIRCLIP	A900-01-112
37	3	BEARING	A900-06-009
38	3	BEARING COLLAR ASSY	038-09D01100
39	3	KNIFE SADDLE	038-05D01100
40	7	TEFLON HEAD PLATE	038-05D02800
41	7,2	CASTOR 4" DIA.	A900-20-002
42	5	STRAINER (OPTION)	A900-34-127
17	7	FREEWHEEL SPROCKET	038-03-01900
18	7,4	CURLING BELT	A900-22-047

**SPARES SHEET 1**

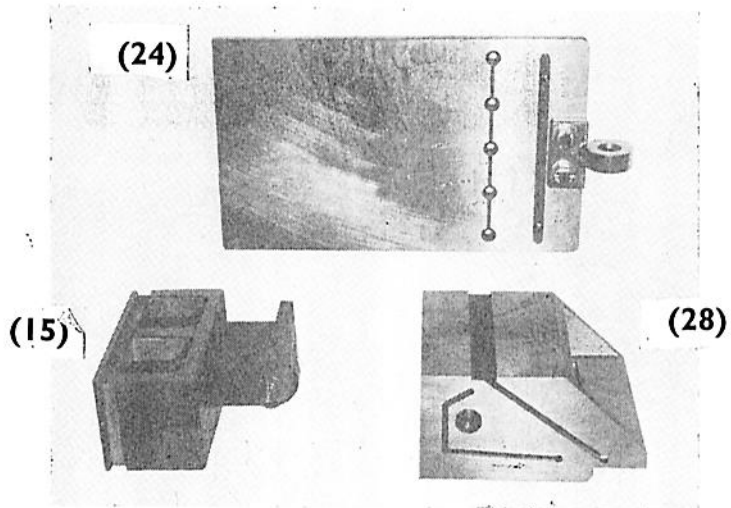
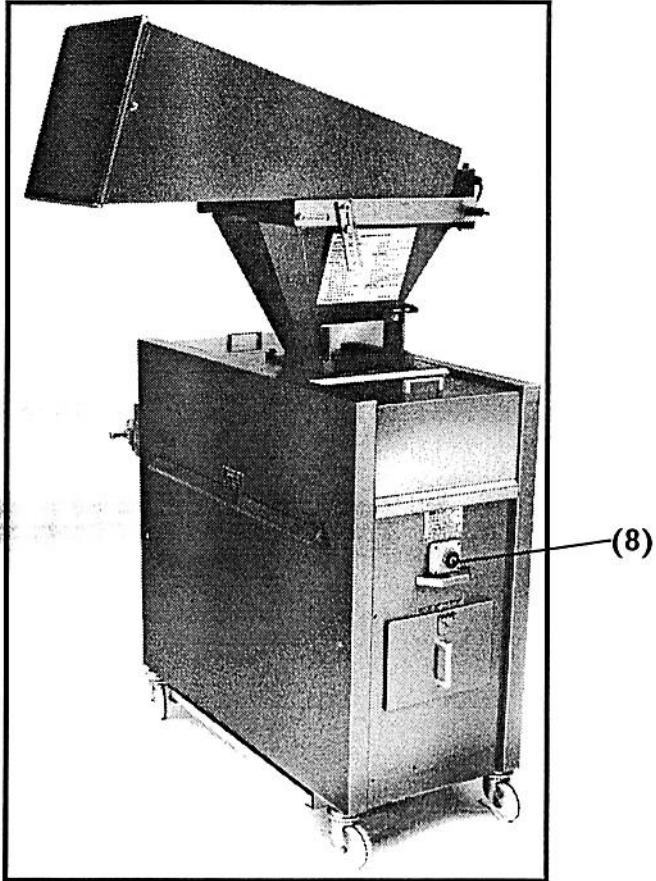

## SPARES SHEET 2

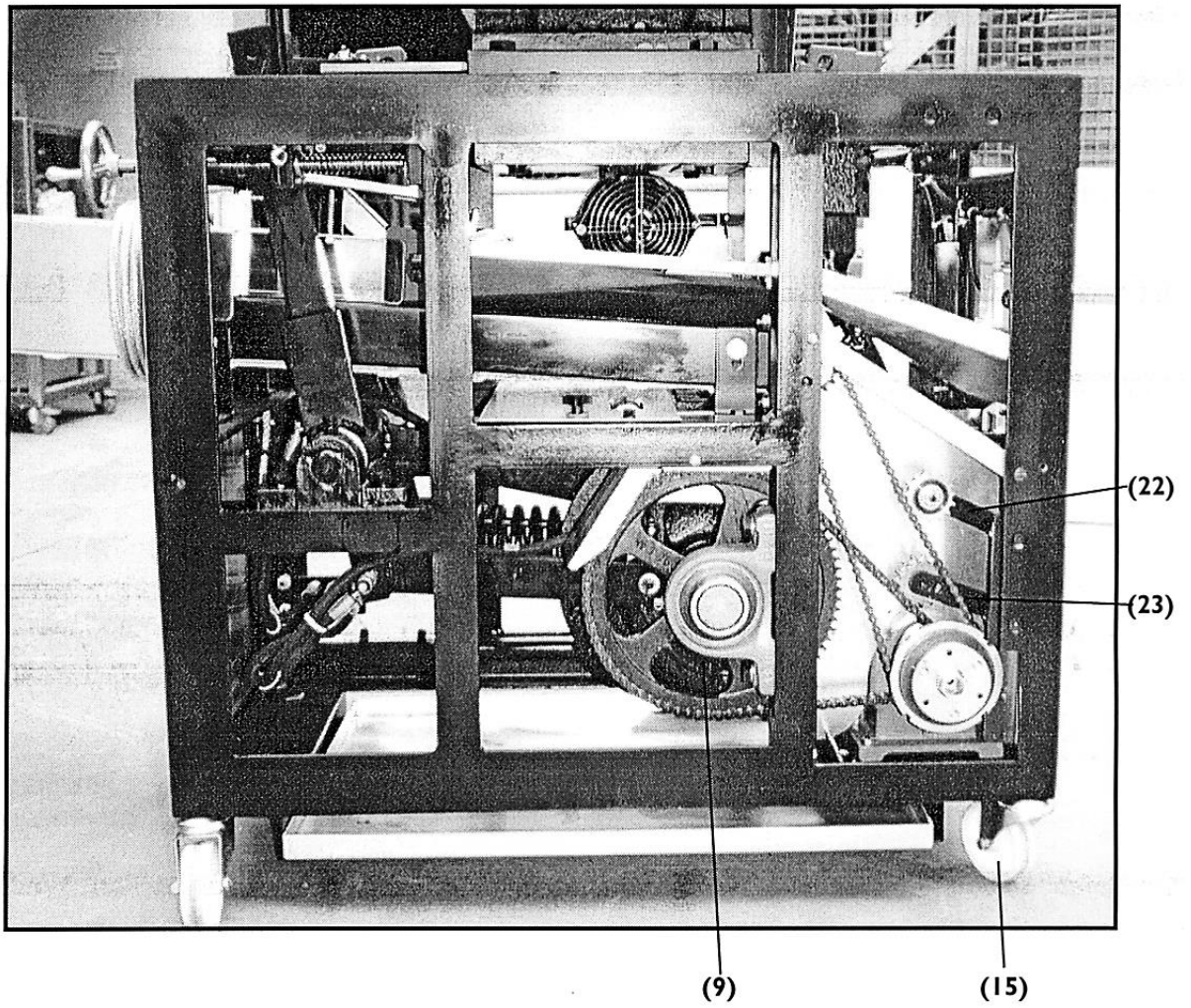

**SPARES SHEET 3**

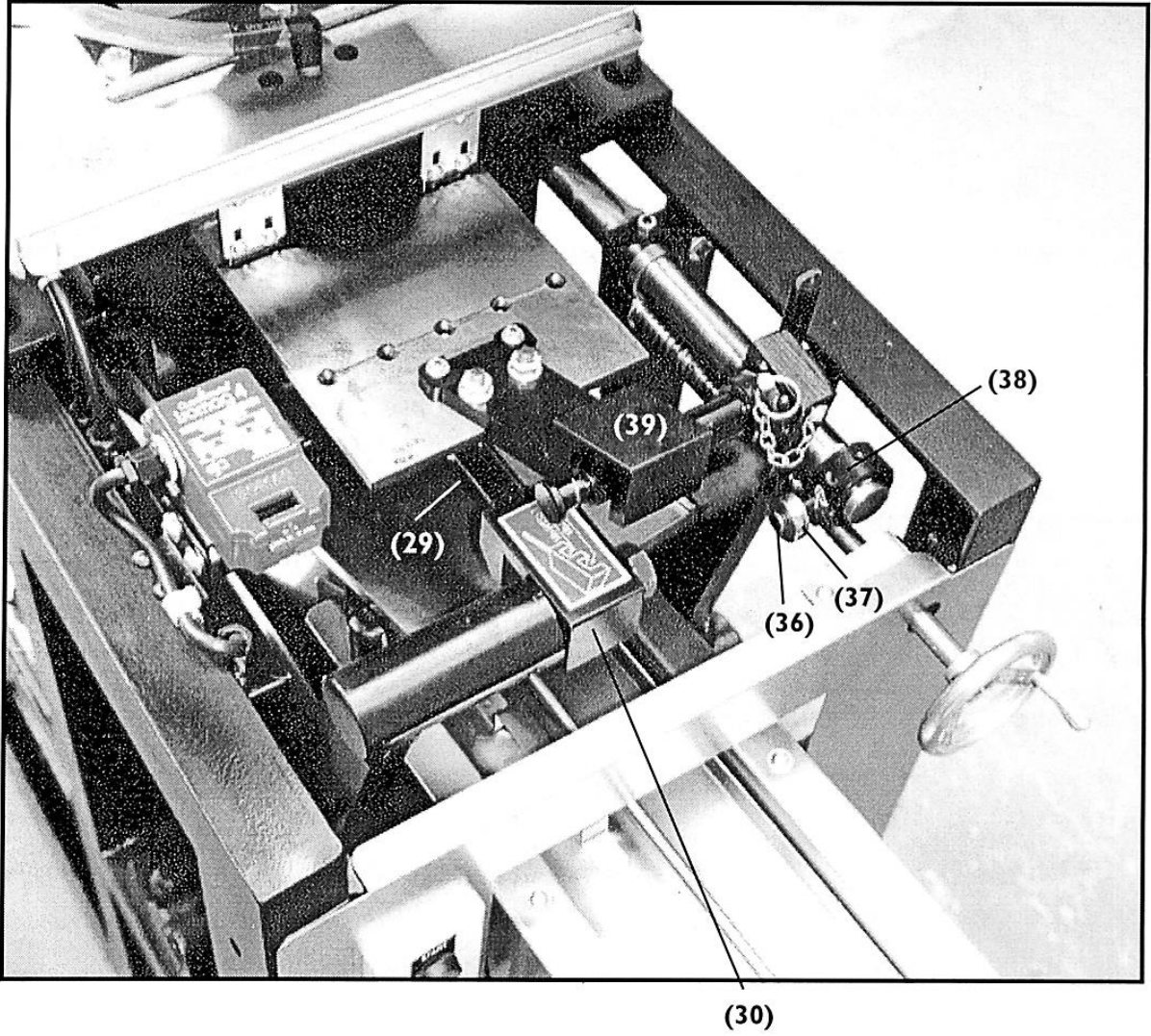

**SPARES SHEET 4**

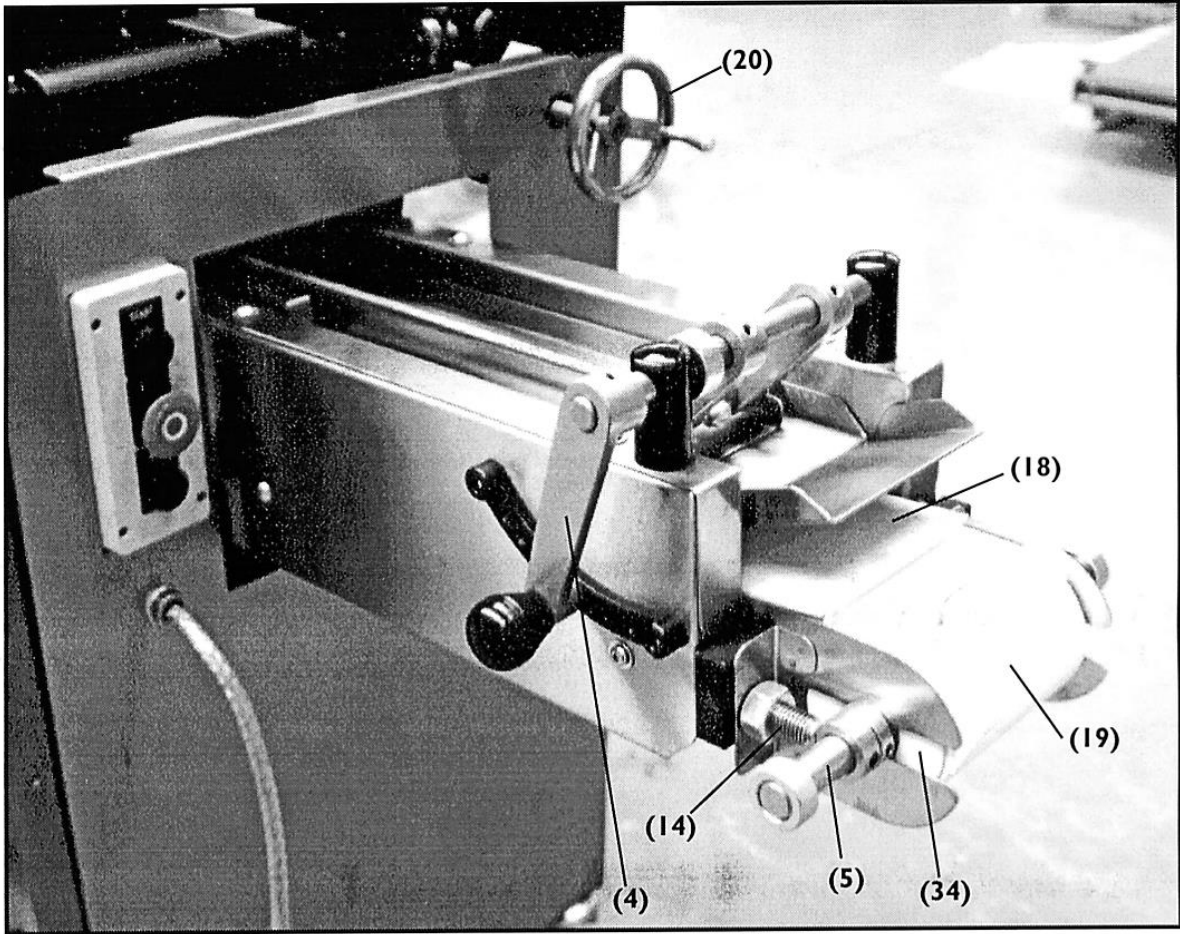

# SPARES SHEET 5

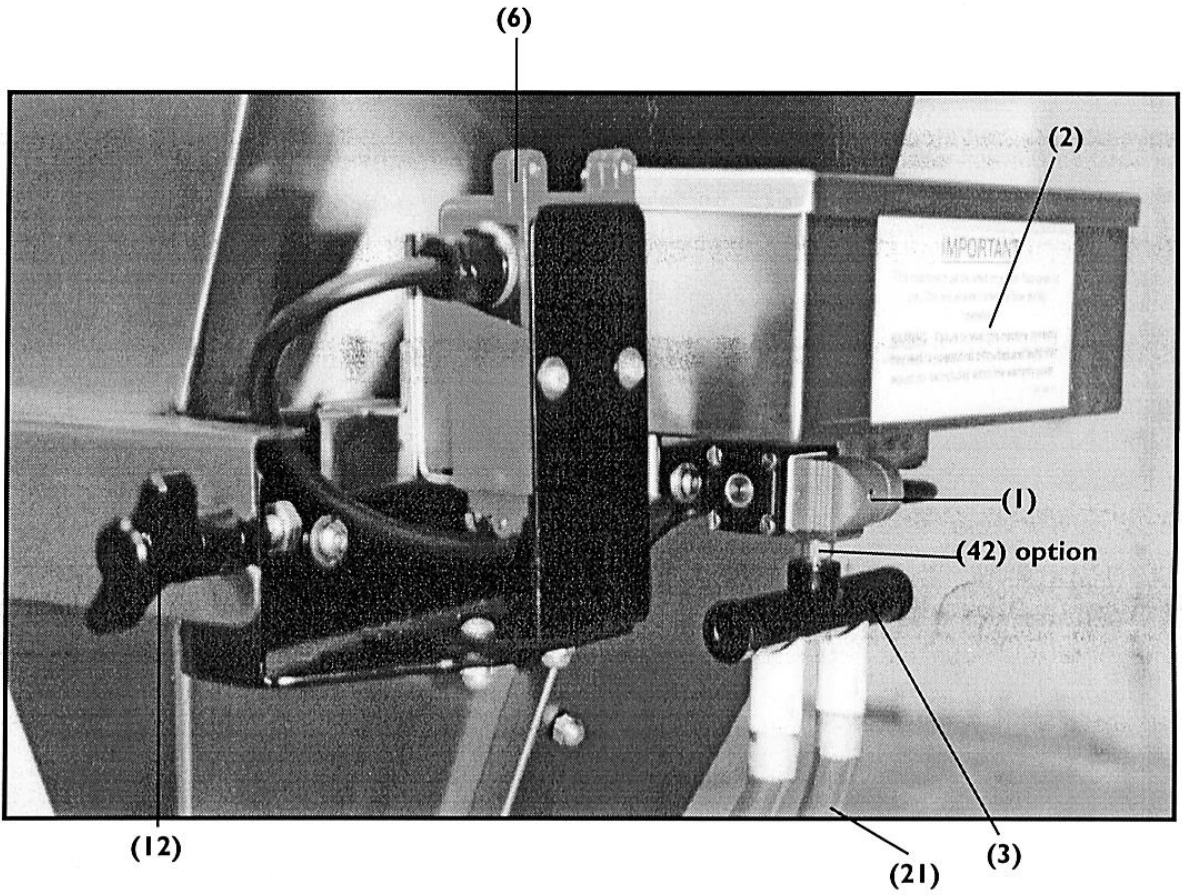



**SPARES SHEET 6**

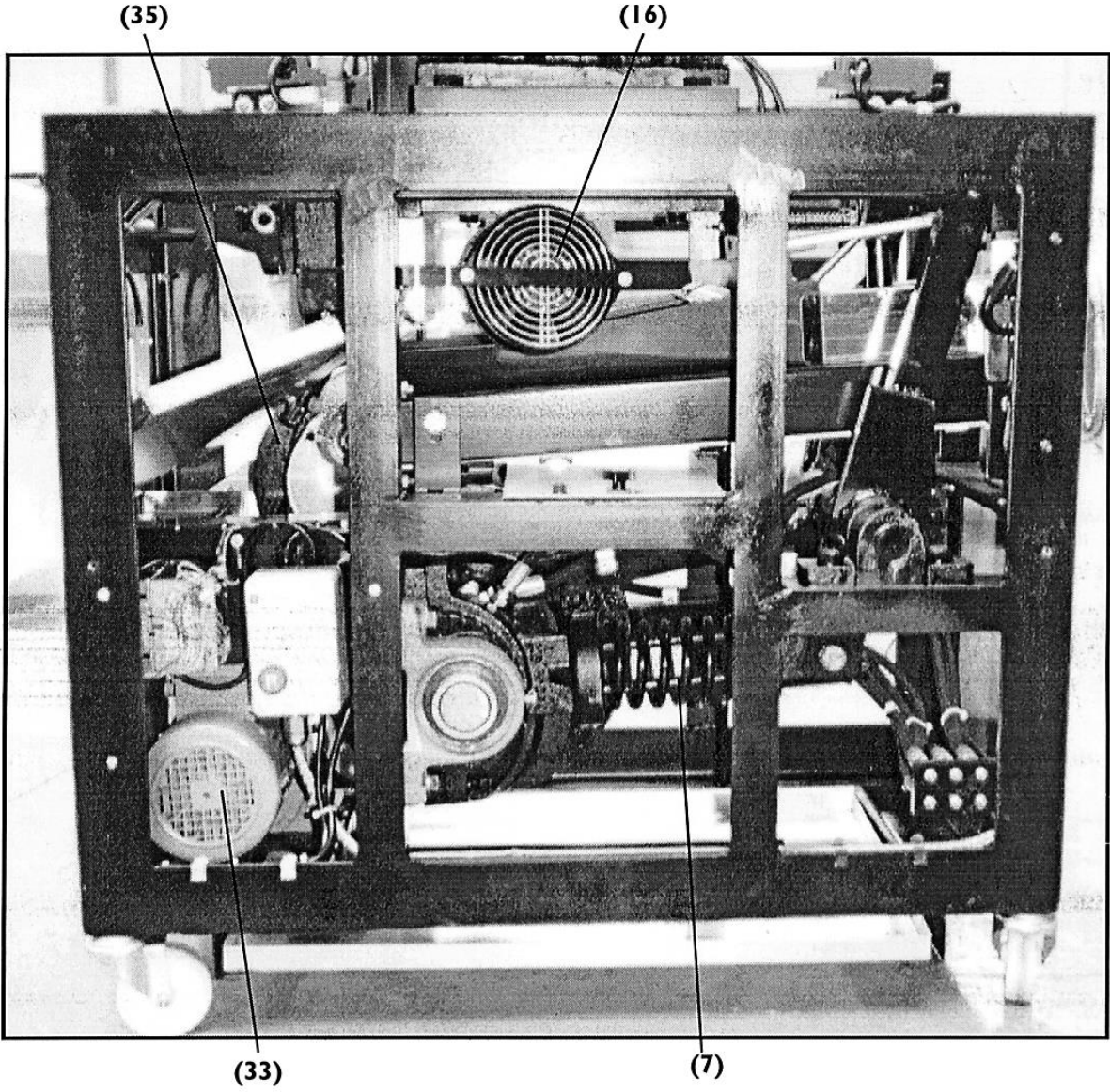

# SPARES SHEET 7

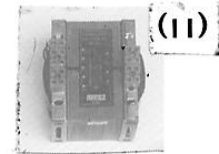
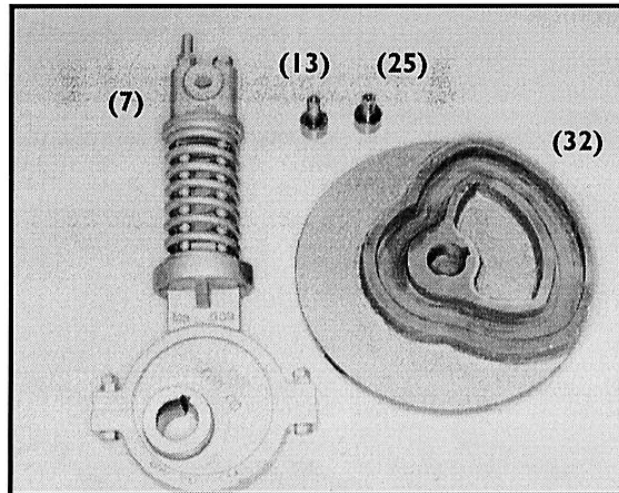
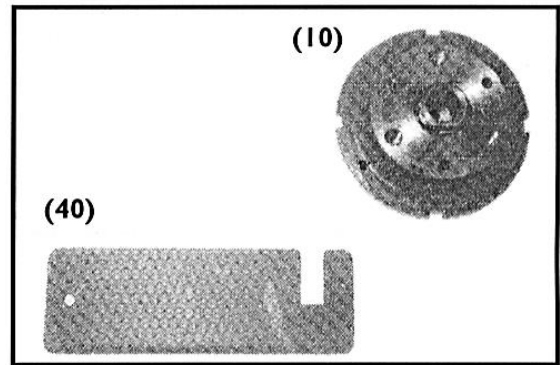
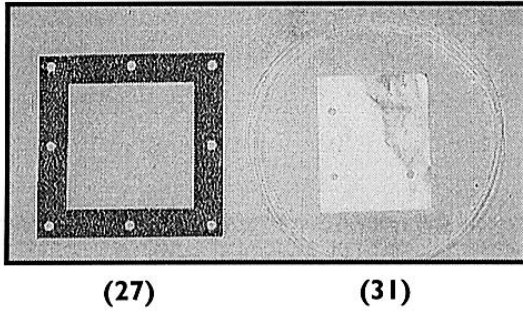
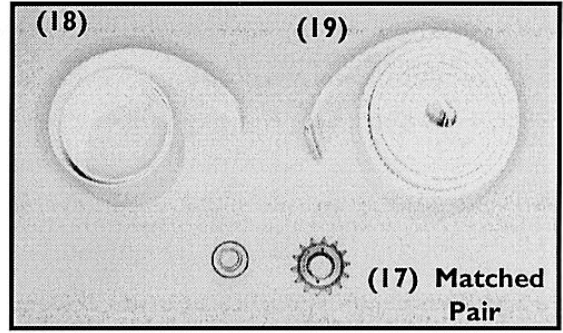
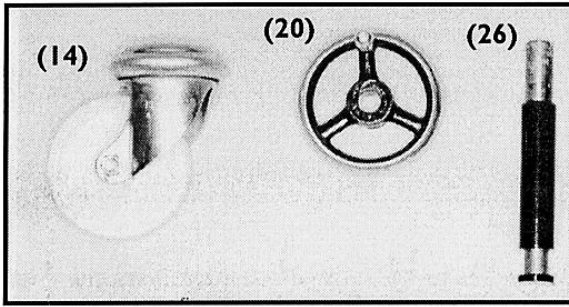



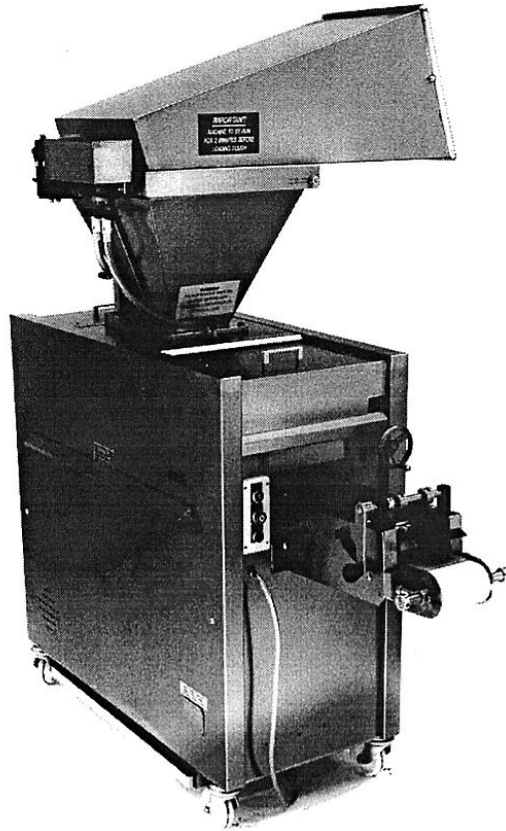

**14.0 ELECTRICAL INFORMATION SECTION**

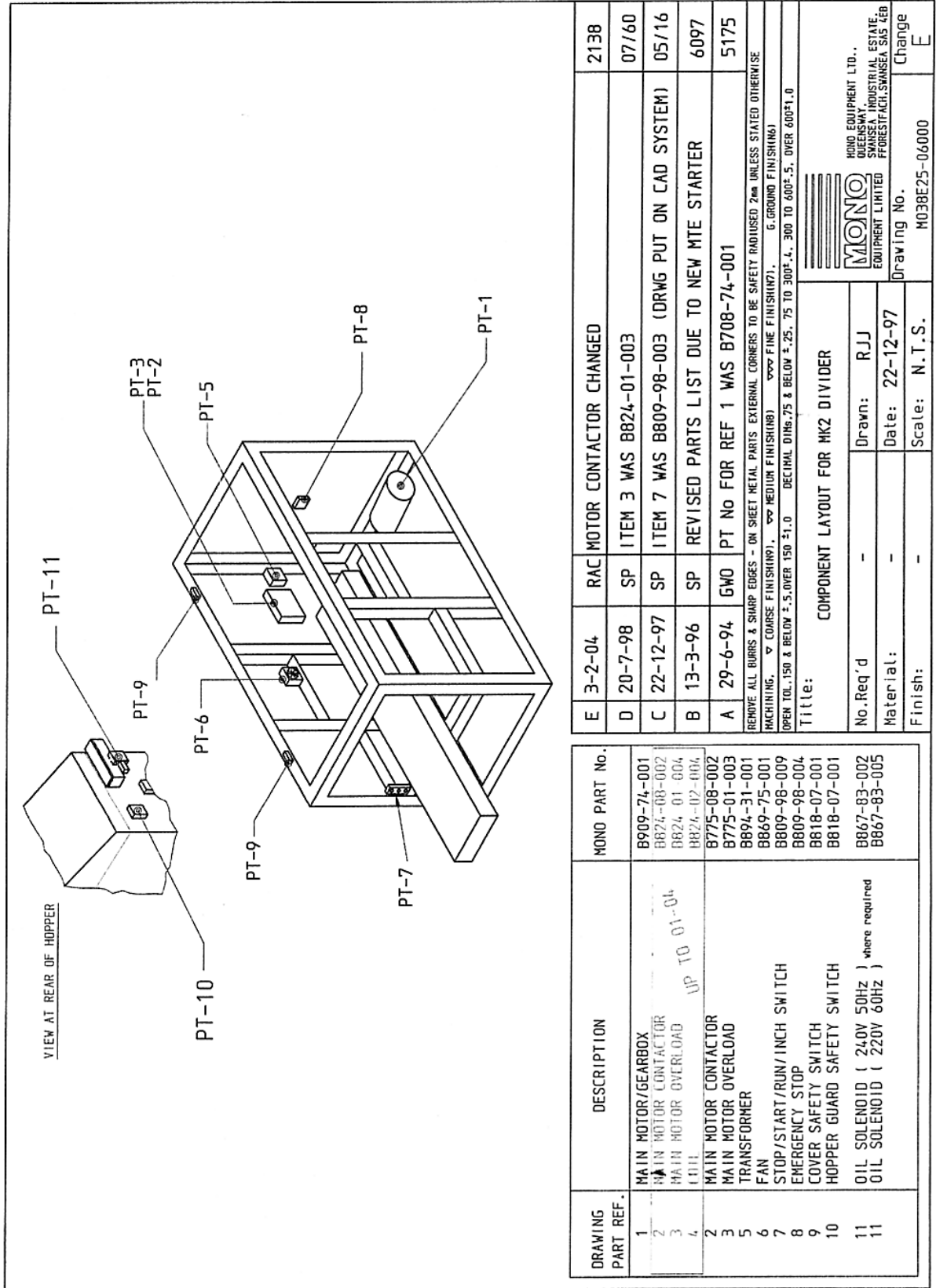

E	3-2-04	RAC	MOTOR CONTACTOR CHANGED	2138
D	20-7-98	SP	ITEM 3 WAS B824-01-003	07/60
C	22-12-97	SP	ITEM 7 WAS B809-98-003 (DRWG PUT ON CAD SYSTEM)	05/16
B	13-3-96	SP	REVISED PARTS LIST DUE TO NEW MTE STARTER	6097
A	29-6-94	GW0	PT No FOR REF 1 WAS B708-74-001	5175

REMOVE ALL BURRS & SHARP EDGES - ON SHEET METAL PARTS. EXTERNAL CORNERS TO BE SAFETY RADIUS. 2mm UNLESS STATED OTHERWISE.  
MACHINING: ▽ COMSE FINISHING, ▽ MEDIUM FINISHING, ▽ FINE FINISHING, ▽ GROUND FINISHING  
OPEN TOL. ±.150 & BELOW ±.5, OVER 150 ±1.0 DECIMAL DIMS. 75 & BELOW ±.25, 75 TO 300 ±.4, 300 TO 600 ±.5, OVER 600 ±1.0

Title: COMPONENT LAYOUT FOR MK2 DIVIDER

No. Req'd: - Drawn: RJJ  
Material: - Date: 22-12-97  
Finish: - Scale: N.T.S.

MONO EQUIPMENT LTD., QUEENSWAY, SWANSEA INDUSTRIAL ESTATE, FORESTFACH, SWANSEA SA5 2EB  
Drawing No. M038E25-06000  
Change E

DRAWING PART REF.	DESCRIPTION	MONO PART No.
1	MAIN MOTOR/GEARBOX	B909-74-001
2	MAIN MOTOR CONTACTOR	B874-08-002
3	MAIN MOTOR OVERLOAD	B824-01-004
4	COIL	B824-02-004
2	MAIN MOTOR CONTACTOR	B775-08-002
3	MAIN MOTOR OVERLOAD	B775-01-003
5	TRANSFORMER	B894-31-001
6	FAN	B869-75-001
7	STOP/START/RUN/INCH SWITCH	B809-98-009
8	EMERGENCY STOP	B809-98-004
9	COVER SAFETY SWITCH	B818-07-001
10	HOPPER GUARD SAFETY SWITCH	B818-07-001
11	OIL SOLENOID ( 240V 50Hz ) where required	B867-83-002
11	OIL SOLENOID ( 220V 60Hz )	B867-83-005

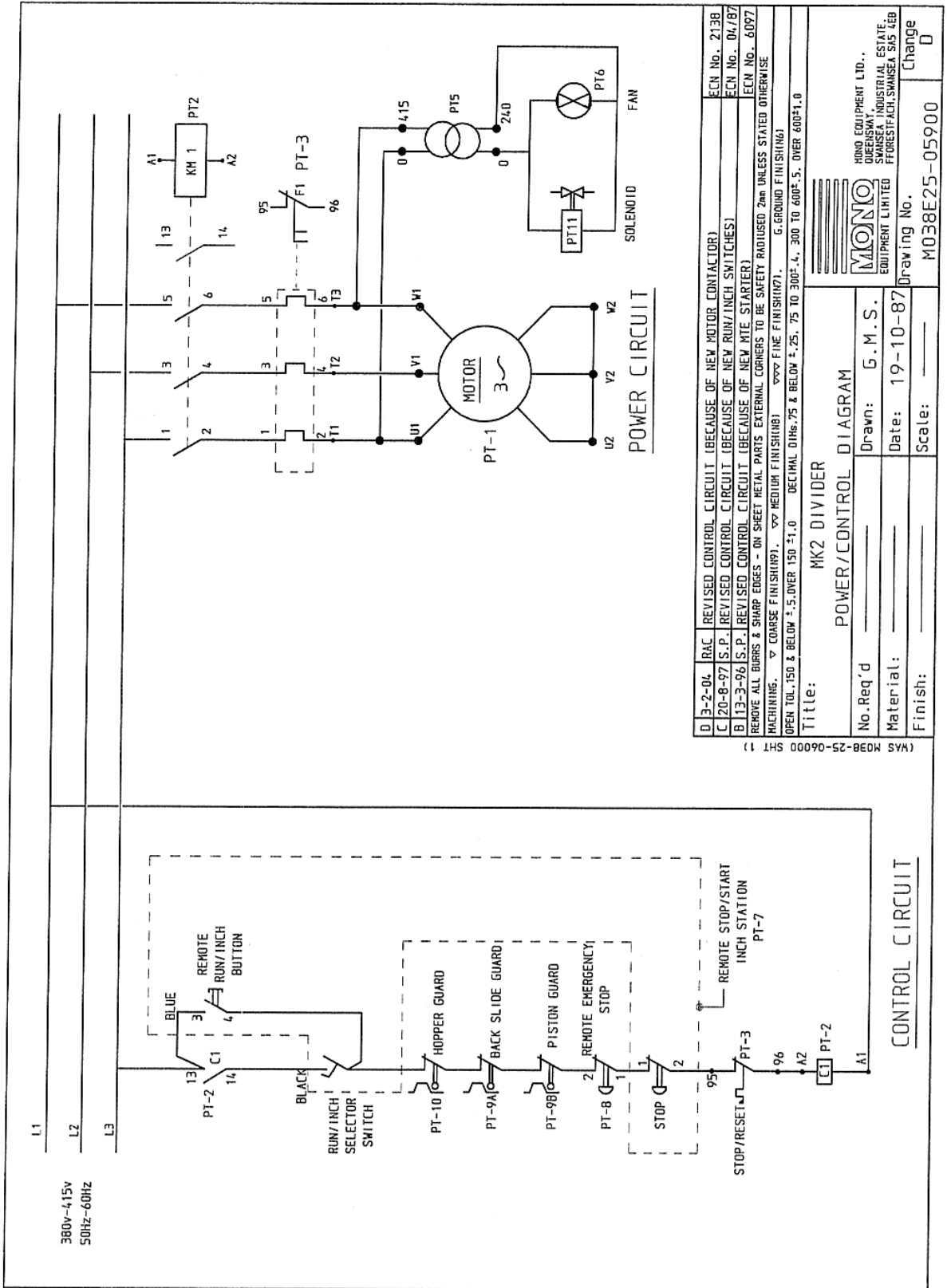

D 3-2-04	RAC	REVISED CONTROL CIRCUIT (BECAUSE OF NEW MOTOR CONTACTOR)	ECN No. 2138
C 20-8-97	S.P.	REVISED CONTROL CIRCUIT (BECAUSE OF NEW RUN/INCH SWITCHES)	ECN No. 04/87
B 13-3-96	S.P.	REVISED CONTROL CIRCUIT (BECAUSE OF NEW MTE STARTER)	ECN No. 6097
REMOVE ALL BURRS & SHARP EDGES - ON SHEET METAL PARTS EXTERNAL CORNERS TO BE SAFETY RADIUS 2mm UNLESS STATED OTHERWISE			
MACHINING: ▽ COARSE FINISH(100) ▽ MEDIUM FINISH(100) ▽ FINE FINISH(100) ▽ GROUND FINISH(100)			
OPEN TOL. 150 & BELOW ±.5. OVER 150 ±1.0 DECIMAL DIMS. 75 & BELOW ±.25. 75 TO 300 ±.4. 300 TO 600 ±1.0			
Title: MK2 DIVIDER			
POWER/CONTROL DIAGRAM			
No. Req'd		Drawn: G. M. S.	
Material:		Date: 19-10-87	
Finish:		Scale:	
		Drawing No. M038E25-05900	
		Change D	

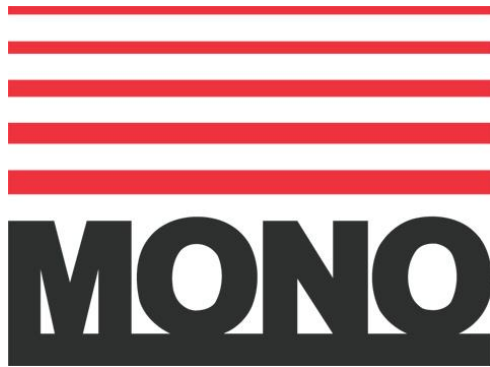

**MONO Equipment**

Queensway, Swansea West Industrial Park, Swansea, SA5 4EB UK

Tel. 01792 561234 Fax. 01792 561016

Email: [mono@monoequip.com](mailto:mono@monoequip.com)

**[www.monoequip.com](http://www.monoequip.com)**

As it is our policy to improve our machines continuously, we reserve the right to change specifications without prior notice.