



www.monoequip.com

Enter **Serial No.** here. _____

In the event of an enquiry please quote this serial number.



OMEGA TOUCH

SOFT DOUGH DEPOSITOR

(400, 450, 580)

OPERATING AND MAINTENANCE MANUAL

The use of templates and/or accessories not produced or supplied by MONO Equipment will invalidate the machine's warranty

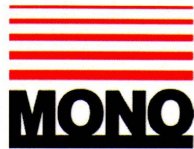

DECLARATION OF CONFORMITY

We hereby declare that this machine complies with the essential health and safety requirements of :-

- The Machinery Directive 2006 / 42 / EC
- The Low voltage Directive 2006 / 95 / EC
- The requirements of the Electromagnetic Compatibility Directive 2004 / 108EC, 91 / 263 / EEC, 92 / 31 / EEC
- The General Safety of Machinery and food processing Standards applicable
- Materials and Articles intended to come into contact with food - Regulation (EC) No. 1935 / 2004
- Good manufacturing practice for Materials intended to come into contact with food - Regulation (EC) No. 2023 / 2006

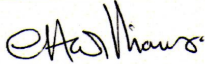
Signed	
G.A.Williams – Quality Manager	

Date	
-------------	--

Machine FG Code.		Machine Serial No.	
-----------------------------	--	-------------------------------	--

A technical construction file for this machine is retained at the following address:

MONO EQUIPMENT
Queensway,
Swansea West Industrial Park,
Swansea
SA5 4EB
UK

MONO EQUIPMENT is a business name of **AFE GROUP Ltd**
Registered in England No.3872673 VAT registration No.923428136

Registered office: Unit 35,
Bryggen Road,
North Lynn Industrial Estate,
Kings Lynn Norfolk,
PE30 2HZ

Failure to adhere to the cleaning and maintenance instructions detailed in this booklet could affect the warranty of this machine.



FOR SAFE WORKING, PAY SPECIAL ATTENTION TO ITEMS MARKED



The use of templates and/or accessories not produced or supplied by MONO Equipment will invalidate the machine's warranty

- 1.0 - INTRODUCTION
- 2.0 - DIMENSIONS
- 3.0 - SPECIFICATIONS
- 4.0 - SAFETY 
- 5.0 - INSTALLATION
- 6.0 - ISOLATION
- 7.0 - CLEANING INSTRUCTIONS
- 8.0 - OPERATING CONDITIONS
- 9.0 - PREPARING FOR OPERATION**
 - 9A – FITTING THE HOPPER*
 - 9B – FITTING A TEMPLATE*
- 10.0 - OPERATING INSTRUCTIONS**
 - 1** – SELECT PRODUCT TYPE
 - 2** – SELECT SAVED NAME OF PRODUCT TYPE
 - 3** – CONFIRM SETUP
 - 4** – OPERATOR SCREEN
 - 5** – EDIT SCREEN
 - 5A** – TRAY SETUP
 - 6** – COPY
 - 7** – DELETE
 - 8** – PASSWORDS
 - 9** – ENGINEERING SETTINGS
 - 10** – FAULT INFORMATION SCREENS
- 11.0 - MAINTENANCE
- 12.0 - SPARES AND SERVICE
- 13.0 - SPARES LIST
- 14.0 - ELECTRICAL INFORMATION

1.0 INTRODUCTION

- The innovative “four axis deposit” design of MONO’s “**Omega Touch**” depositor allows it to recreate most of the hand movements of the Master confectioner. This makes the “**Omega Touch**” capable of exceptional accuracy of product weight, size and shape.
- Maintenance is kept to a minimum and the smooth body design makes daily cleaning quick and easy.
- Easy to use computer software gives access to 550 programs, which are stored in the memory and easily recalled for use or modification. Control is via a colour touch screen with graphically represented products already installed that can be created or edited to the required product.
- It is available with soft dough hoppers. There is also a large selection of templates and nozzles.

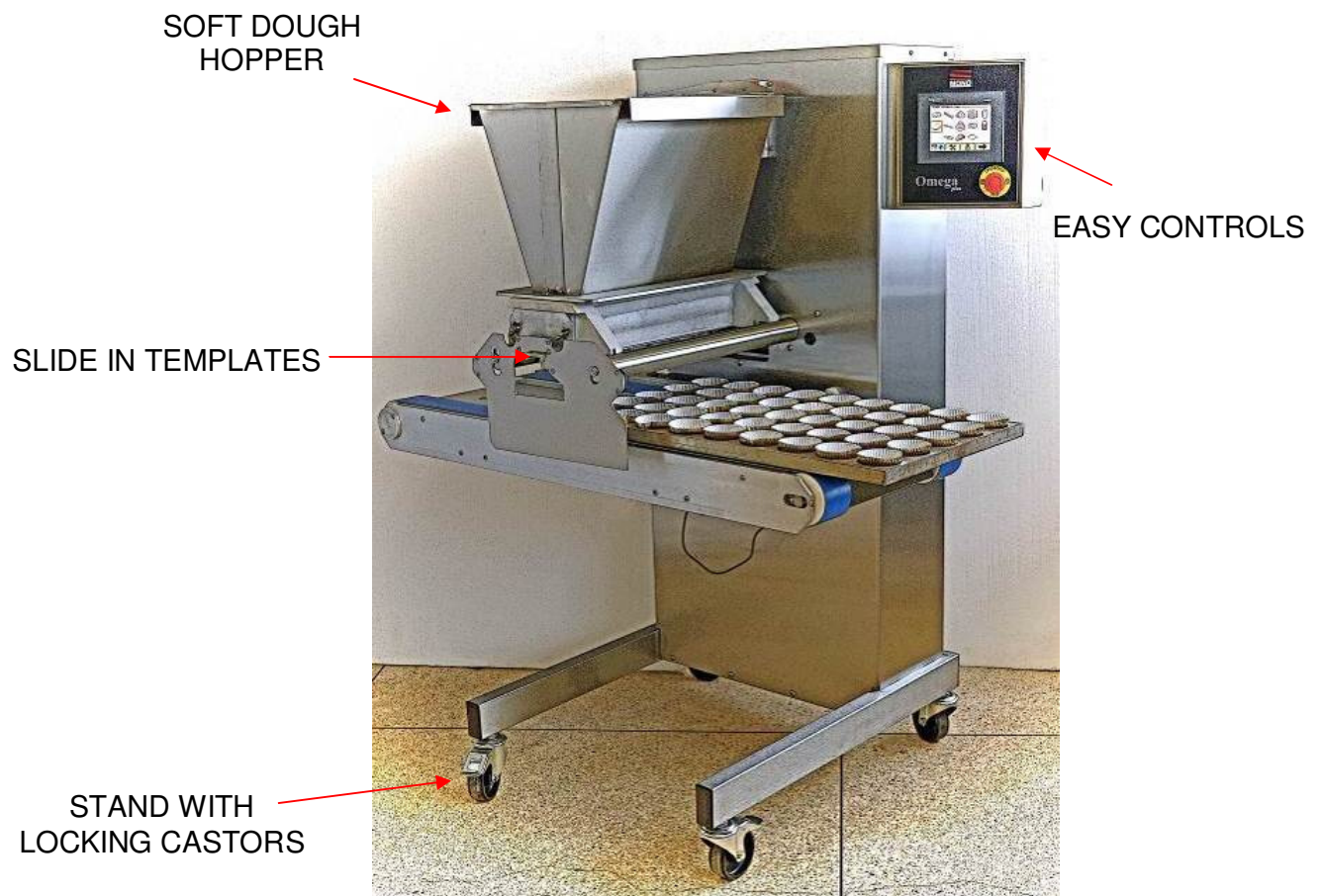

As it is our policy to improve our machines continuously,
we reserve the right to change specifications without prior notice

2.0 DIMENSIONS

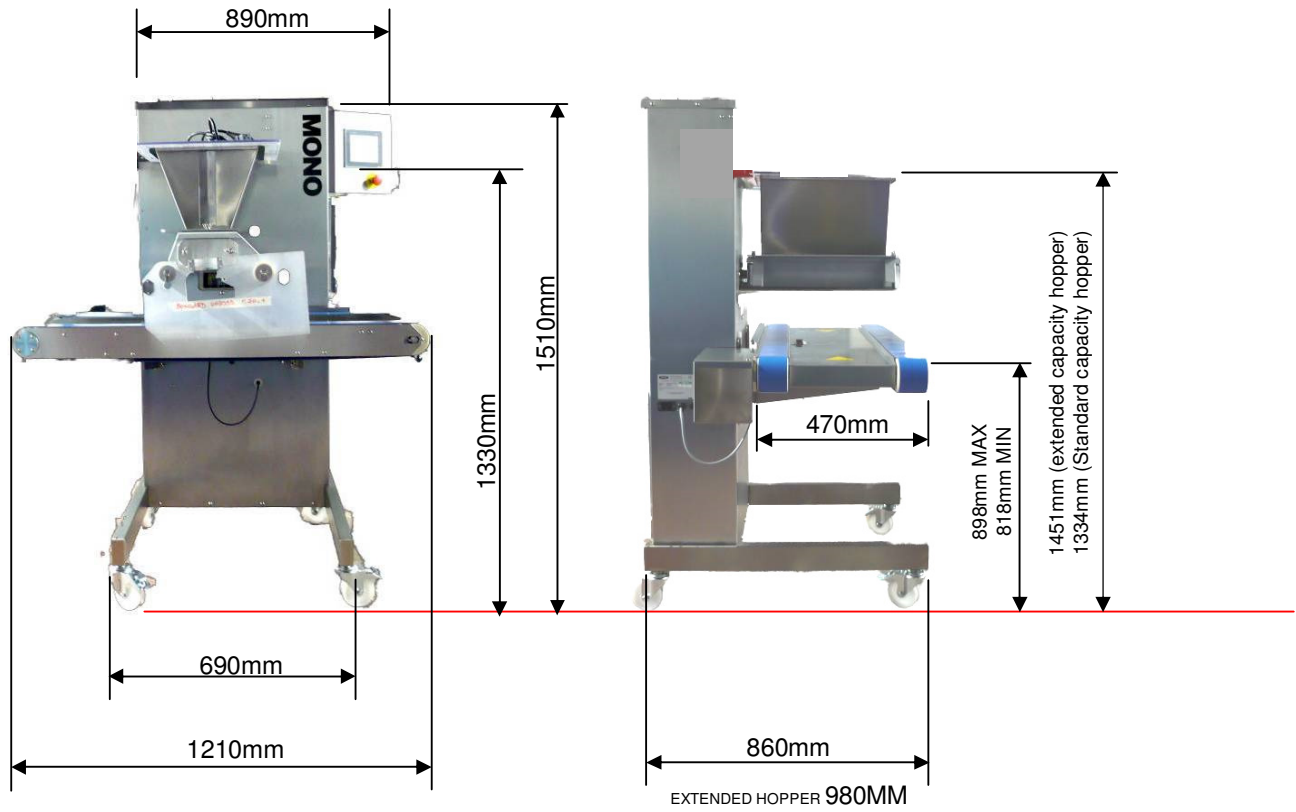

3.0 SPECIFICATIONS

SOFT DOUGH

MODEL (Nom. hopper width (mm))	400	450	580
Weight (with hopper fitted) (Kg) :	176	185	194
Standard hopper Capacity (litre) :	20	22.5	29
Extended hopper Capacity (litre) :	36	41	53

Power: Single phase, 13A max load. Suitable for 200v, 220v, 230v, and 240v, 50-60 Hz supply.

MAX RATING 2.5kW single phase fused at 13A

Cycles per minute	=	Up to 35
Min distance between trays	=	50mm
Max vertical travel	=	80mm
Max program storage	=	650
Number of languages	=	18
Noise level	=	Less than 85dB
Electronics	=	All microprocessor controlled

NOTE:

The minimum deposit that can be made depends on several factors - recipe, mixing method, template size, nozzle size and deposit speed.

As a guide the following is the minimum that should be attempted:

Macaroons	6g,
Meringues	3g,
Choux Paste	5g,
Viennese	4g,
Sponge Drops	4g.

However, consult **Mono Equipment** if intended product falls outside the above general machine specification to determine the exact capabilities of the "Omega" with any specific product.

As it is our policy to improve our machines continuously, we reserve the right to change specifications without prior notice



4.0 SAFETY



- 1 **Never use a machine in a faulty condition** and always report any damage.
- 2 **Only trained engineers** may remove parts that need a tool to remove them.
- 3 Always ensure hands are dry before touching any electrical appliance (including cable, switch and plug). **NEVER move machinery by pulling on the power cords or cables.**
- 4 **Ensure that the floor area around the OMEGA is clean to avoid slipping** – especially if carrying heavy hopper and template components to and from the machine.
- 5 **All operatives must be fully trained.**
Use of the machine can prove dangerous if:
 - the machine is operated by **untrained or unskilled staff**
 - the machine is not used for its **intended purpose**
 - the machine is **not operated correctly**

All safety devices applied to the machine during manufacture and the operating instructions in this manual are required to operate this machine safely. The owner and the operator are responsible for operating this machine safely.
- 6 People undergoing training on the machine must be under **direct supervision**.
- 7 **Do not operate the machine with any panels or guards removed.**
They are there to protect you.
- 8 **No loose clothing** or jewellery should be worn while operating the machine.
- 9 **Switch off power** at the mains isolator when machine is not in use and **before** carrying out any **cleaning** or **maintenance**.

10 The bakery manager or the bakery supervisor should carry out **daily safety checks** on the machine.

11 Do not operate machine without hopper **template and guard fitted correctly**.

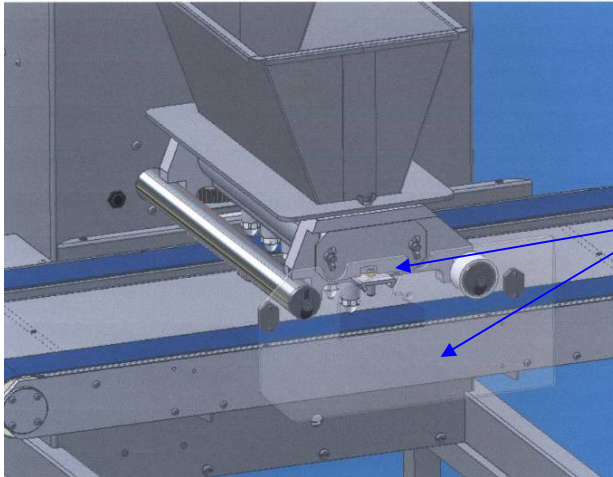

**(11) HOPPER TEMPLATE AND
GUARD FITTED**

NOTE

Guard can be plastic or metal depending
on the machine model

12 Due to the essential requirement for handling heavy components during cleaning, it is recommended that **protective footwear** be worn when carrying out such procedures.

**ALL CLEANING AND MAINTENANCE OPERATIONS MUST
BE MADE WITH MACHINE DISCONNECTED FROM THE
POWER SUPPLY.**

5.0 INSTALLATION

- 1 Ensure that the depositor is connected to correct electric supply as specified on the serial number plate on the side of the machine.
- 2 Ensure that the correct fuse rating is fitted in the electrical supply

6.0 ISOLATION

▲ IN AN EMERGENCY, SWITCH OFF AT THE ELECTRICAL MAINS WALL ISOLATOR, OR PUSH THE EMERGENCY STOP BUTTON.

To release the emergency stop button, turn clockwise. ↻



STOP BUTTON

7.0 CLEANING INSTRUCTIONS

NOTE:



- Cleaning must be carried out by fully trained personnel only.
- Isolate machine from mains supply before carrying out any cleaning.
- Do not steam clean or use a jet of water.

-Do not use any form of caustic detergent or abrasive cleaners.-

All the outer surfaces of the machine should be wiped over daily with warm soapy water.

CLEANING SOFT DOUGH HOPPERS

The feed hopper, pump assembly, template, nozzles etc. should be removed from the machine and dismantled for thorough cleaning between product mix changes.

1. Open top safety guard and remove excess mixture remaining in the feed hopper.
2. Lift off front safety cover and locking-ring.

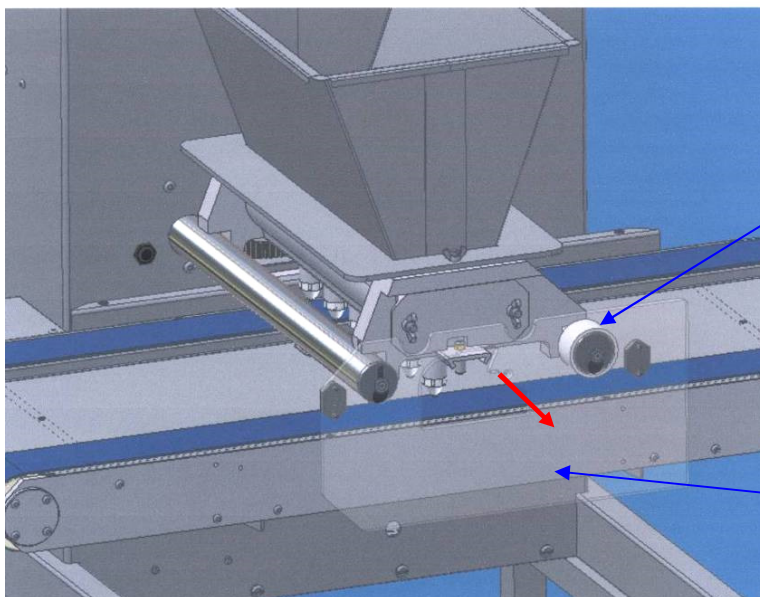

LOCKING RING

SAFETY COVER

NOTE

Cover can be plastic or metal depending on the machine model

3. Slacken template clamp strip nuts or thumbscrews (depending on type of hopper)
Remove fitted template from pump assembly by sliding out to avoid subsequent damage.

NOTE.

Thumbscrews only need to be released slightly to allow the template to slide away from the pump assembly. If loosened too much, the template will have to be supported.

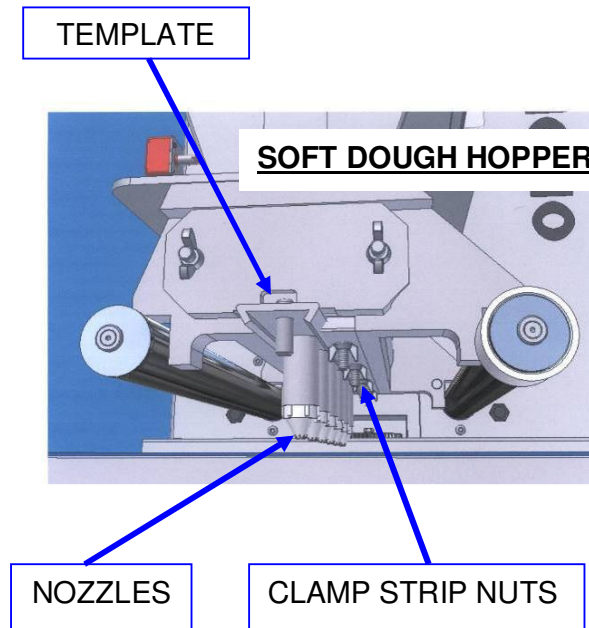

- 4 To reduce weight and bulk, separate and remove empty feed hopper from pump assembly whilst still on the machine by unscrewing the wing nuts.

To gain access to the inner wing nut, slide the complete hopper away from the machine body slightly (keep on support bars) - this will also disengage the pump assembly from the drive shaft.

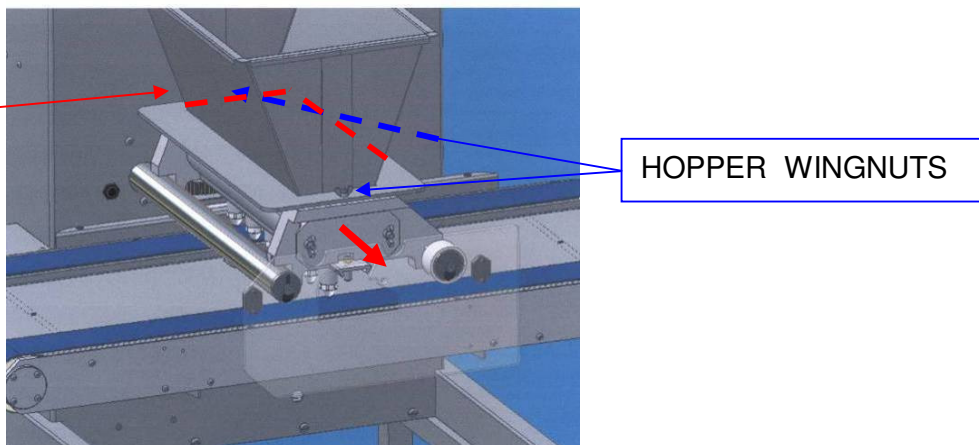

Ensure that the nuts are placed where they will not be lost.



CAUTION:

The feed hopper and pump assembly exceeds 25kg and will need to be lifted off by two people, or dismantled into smaller components while still on the machine.

Take care to avoid damage to the sealing surface of the feed hopper during removal, cleaning, assembly and storage.

5. After removing the feed hopper, check condition of feed hopper seal.

6. Unscrew the end cap retaining nuts from the accessible side of the pump assembly.
(Ensure that the nuts are placed where they will not be lost).

FEED HOPPER
SEALING SURFACE

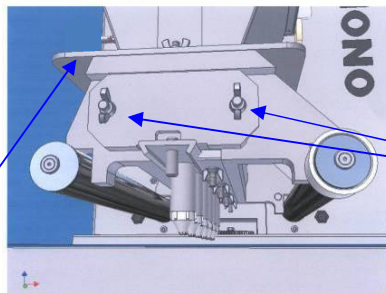

ENDCAP NUTS

7. Withdraw the end-cap with the pump gears.

Ensure that the 'O' sealing ring on the inside of the end-cap is not damaged during cleaning.

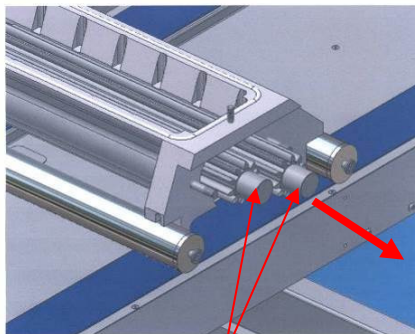

PUMP GEARS
REMOVE WITH END CAP
(NOT SHOWN)

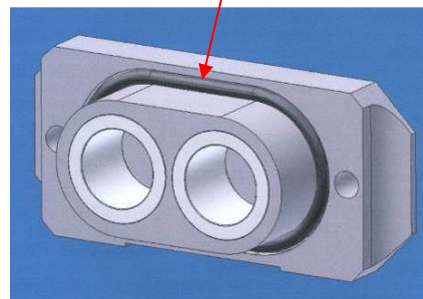

'O' RING IN GROOVE

END CAP

4. Remove remainder of pump assembly from the machine and remove remaining end-cap to fully dismantle pump assembly components for cleaning.

8.0 OPERATING CONDITIONS

To obtain the best product results and consistent operation,

- ✓ Make sure the depositor is used on a **level floor**.
- ✓ Ensure **flat trays** of consistent length, width, material and edge dimensions are used.
- ✓ Ensure **undamaged** nozzles and templates are used.
- ✓ Keep the machine **clean**.



9.0 PREPARING FOR OPERATION

The use of templates and/or accessories not produced or supplied by MONO Equipment will invalidate the machine's warranty

- 1 Select template and nozzles required and fit as section 9a & 9b following.
Fill hopper with mix and close hopper cover.

It is recommended that when heavy mixes are used, the inside of the hopper should be coated with vegetable oil; for lighter mixes such as meringue, dampen with water. The oil or water will help the mix to settle down the hopper walls and prevent air being sucked in.

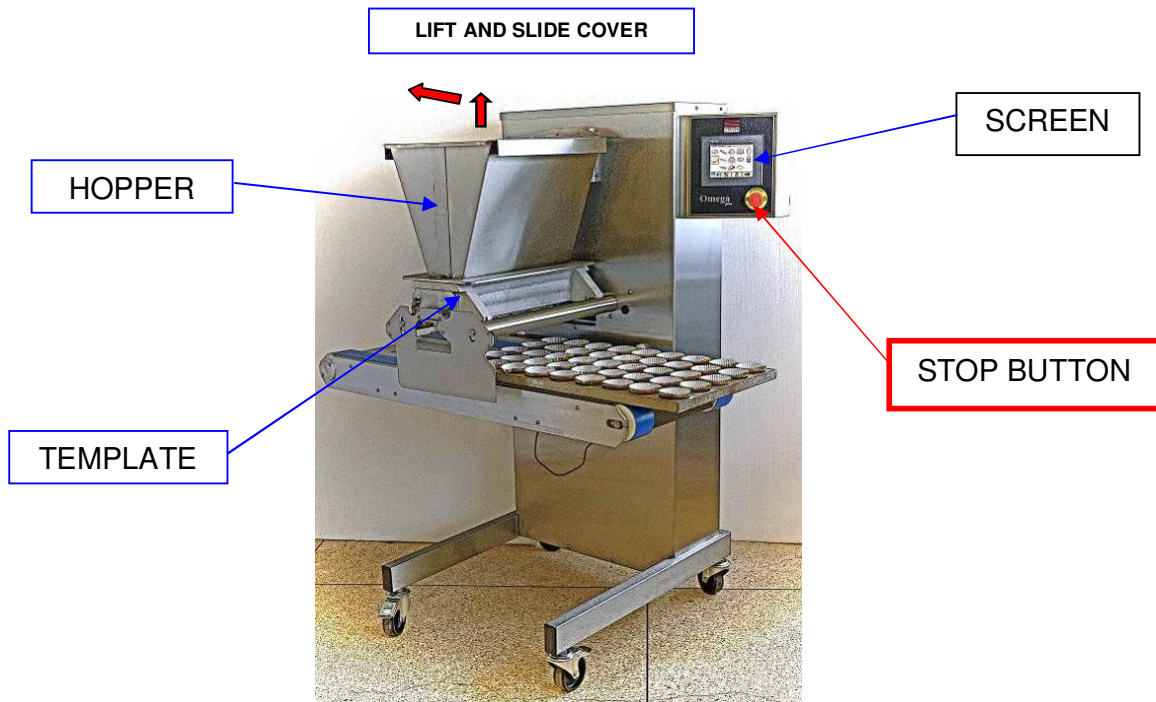

- 2 Connect power cable to electrical supply.
Make sure stop button is in released position (turn clockwise if required).
- 3 Select an existing program or create a new program through the on-screen menus.
(see section 10 operation)
- 4 The machine is now ready for operation.

9a FITTING THE HOPPER

CAUTION SHOULD BE TAKEN WHEN FITTING HOPPER AND PUMP ASSEMBLY AS WEIGHT EXCEEDS 25KGS ON SOME MODELS
It will need to be lifted off by two people, or dismantled into smaller components while still on the machine.
MAKE SURE FLOOR AREA AROUND MACHINE IS CLEAN

To reduce weight and bulk fit the complete hopper assembly in two stages - first the pump assembly onto the support bars, then the feed hopper body onto the pump assembly.

- 1 By hand, align pump assembly drive gear roller with drive shaft on machine.
- 2 Fit hopper to pump assembly and secure with wing nuts.
- 3 Slide hopper on support bars until fully up against machine.

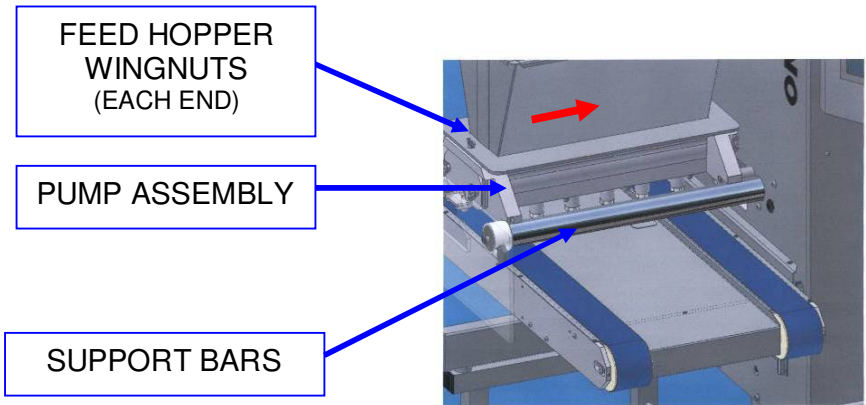

SOFT DOUGH

- 4 After the hopper is fitted, the hopper-locking ring **MUST BE** replaced on the support bar and safety cover replaced with the reflectors facing towards machine body. (The machine will not work without the cover in place).

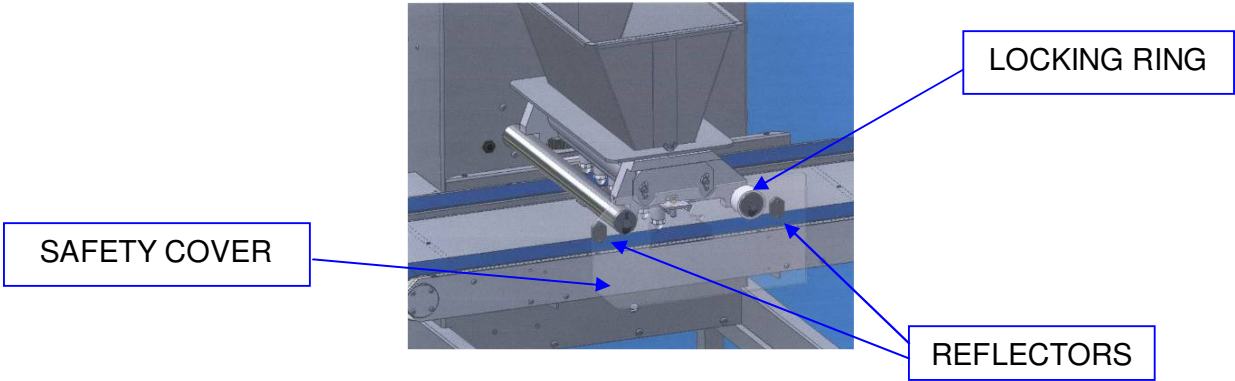

DO NOT OPERATE MACHINE WITHOUT TEMPLATE FITTED

BEFORE USING STRAIGHT & OFFSET NOZZLE HOLDERS **“O” RINGS MUST BE FITTED**

Nozzle holders provide the means of attaching standard plastic nozzles to the soft dough rotary templates and the sealing rings need to be fitted before using and may need replacing occasionally to ensure correct operation.

“O” RING PART NUMBER = A900-12-010 (SUPPLIED IN BAGS OF 20)



LOOP FIRST RING OVER END



SLIDE RING DOWN TO GROOVE



FIRST RING IN CORRECT POSITION



LOOP SECOND RING OVER END



SLIDE RING DOWN TO SECOND GROOVE,
PASSING OVER FIRST RING



SECOND RING IN CORRECT POSITION

9b FITTING A TEMPLATE

- **Soft dough**

Non-rotary templates that can be fitted with nozzles, requires screwing the nozzles into the threaded holes provided.

Rotary templates can have plastic nozzles screwed into nozzle holders (straight or offset).

OR

Metal nozzles secured in place by a separate nut.

- 1 Select template and nozzles required.
(Nozzles are not required for sheeting, staggered or stub templates)
- 2 Attach nozzles to template body:

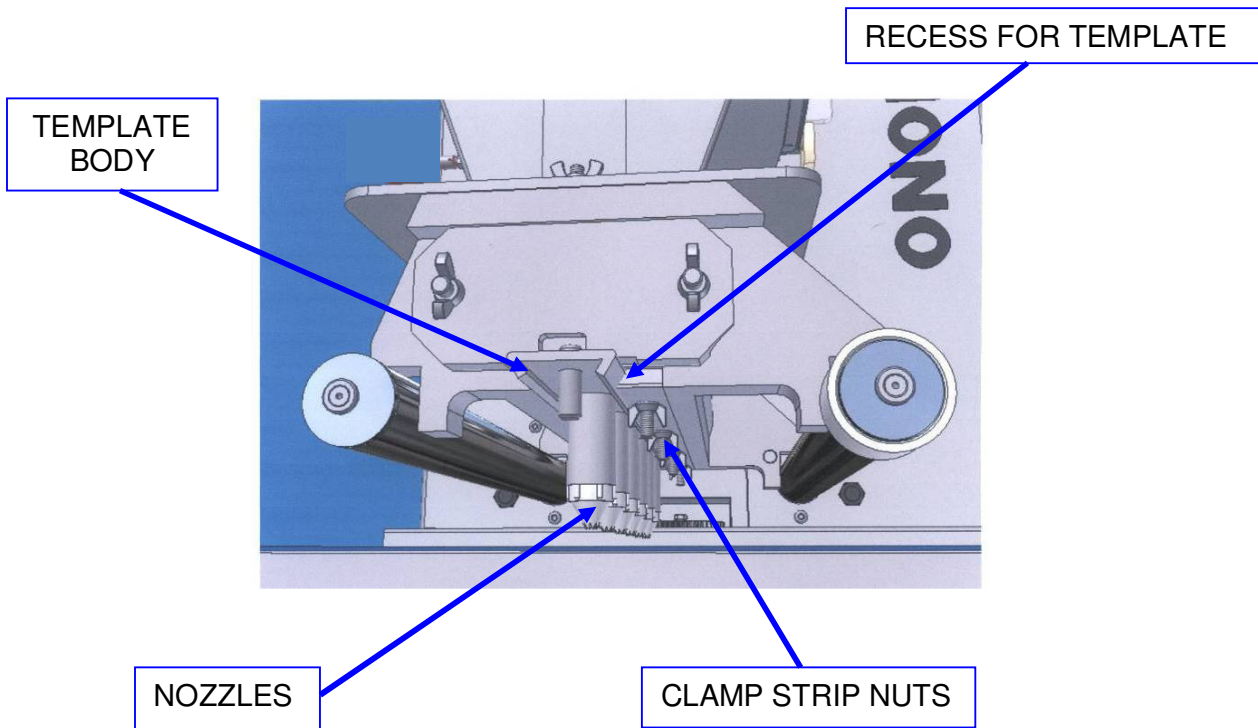

- 3 Slide template into matching recess at base of pump assembly until the stop is in position.
- 4 Tighten nuts on clamp strip (on underside of pump assembly) to secure template.

NOTE. *If the nuts are not securely tightened, leakage of mix will occur, affecting deposit weights.*



DO NOT OPERATE MACHINE WITHOUT TEMPLATE FITTED



10.0 'OMEGA TOUCH' OPERATION

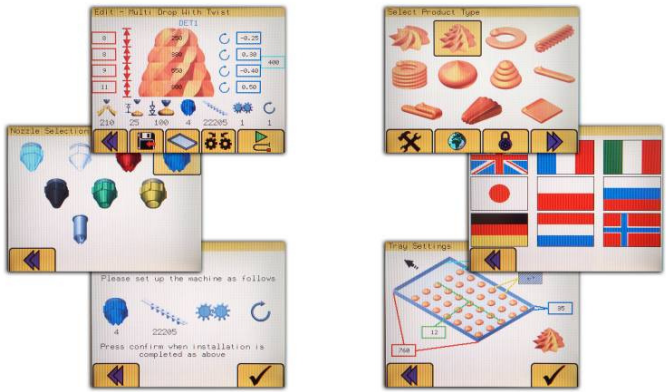
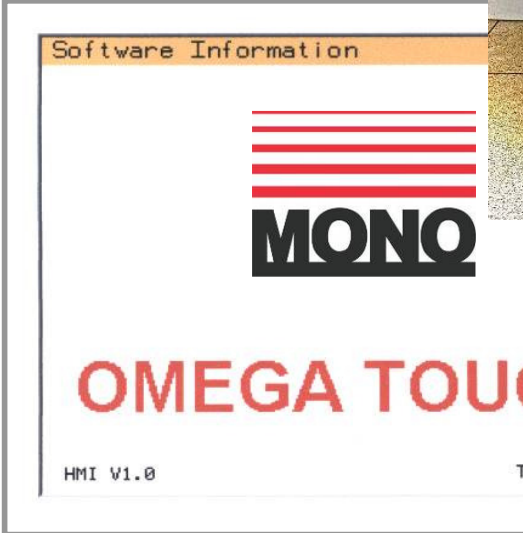

ALL OPERATIONS ARE ACTIVATED BY TOUCHING AREAS ON THE SCREEN WITH A FINGER. DO NOT USE EXCESSIVE FORCE OR HARD OBJECTS AS THIS WILL INVALIDATE MACHINE WARRANTY.

OPERATING KEY

FOR FOLLOWING INSTRUCTIONS

BLUE = OPERATION FOLLOW BLUE ARROWS AND BOXES TO OPERATE THE DEPOSITOR WITH ALREADY SAVED PROGRAMS

RED = CHANGE SETTINGS FOLLOW RED ARROWS AND BOXES TO CHANGE SETTINGS AND CREATE NEW PROGRAMS

 **= KEYBOARD ENTRY REQUIRED** WHEN KEYBOARD APPEARS, A CODE MUST BE ENTERED BY TOUCHING THE NUMBERS IN THE CORRECT ORDER

IF A GREY BOX IS SHOWN IN THE BUTTON DESCRIPTION
 e.g. 7 GO TO THE CORRESPONDING PAGE FURTHER
 ON IN THE INSTRUCTIONS.

(MARKED IN TOP RIGHT HAND CORNER OF EACH PAGE)

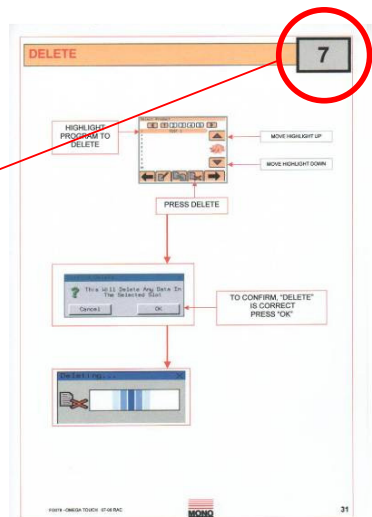
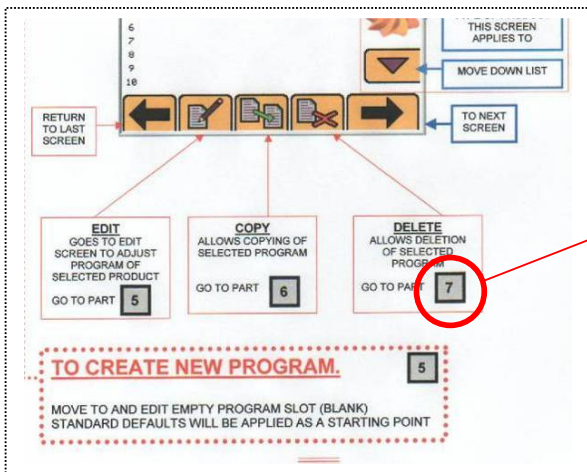

SELECT PRODUCT TYPE

SELECT PRODUCT TO DEPOSIT OR TO CREATE NEW PROGRAM



ALL OPERATIONS ARE ACTIVATED BY TOUCHING AREAS ON THE SCREEN WITH A FINGER.
DO NOT USE EXCESSIVE FORCE OR HARD OBJECTS AS THIS WILL INVALIDATE MACHINE WARRANTY.

TOUCH THE SCREEN FOR THE TYPE OF PRODUCT REQUIRED THEN → TO MOVE TO NEXT SCREEN

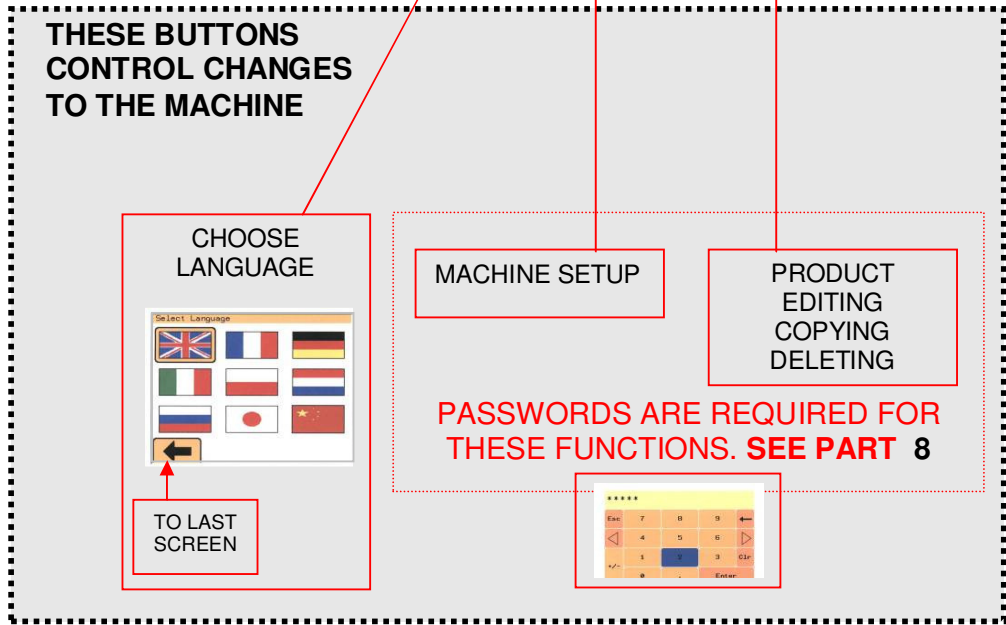
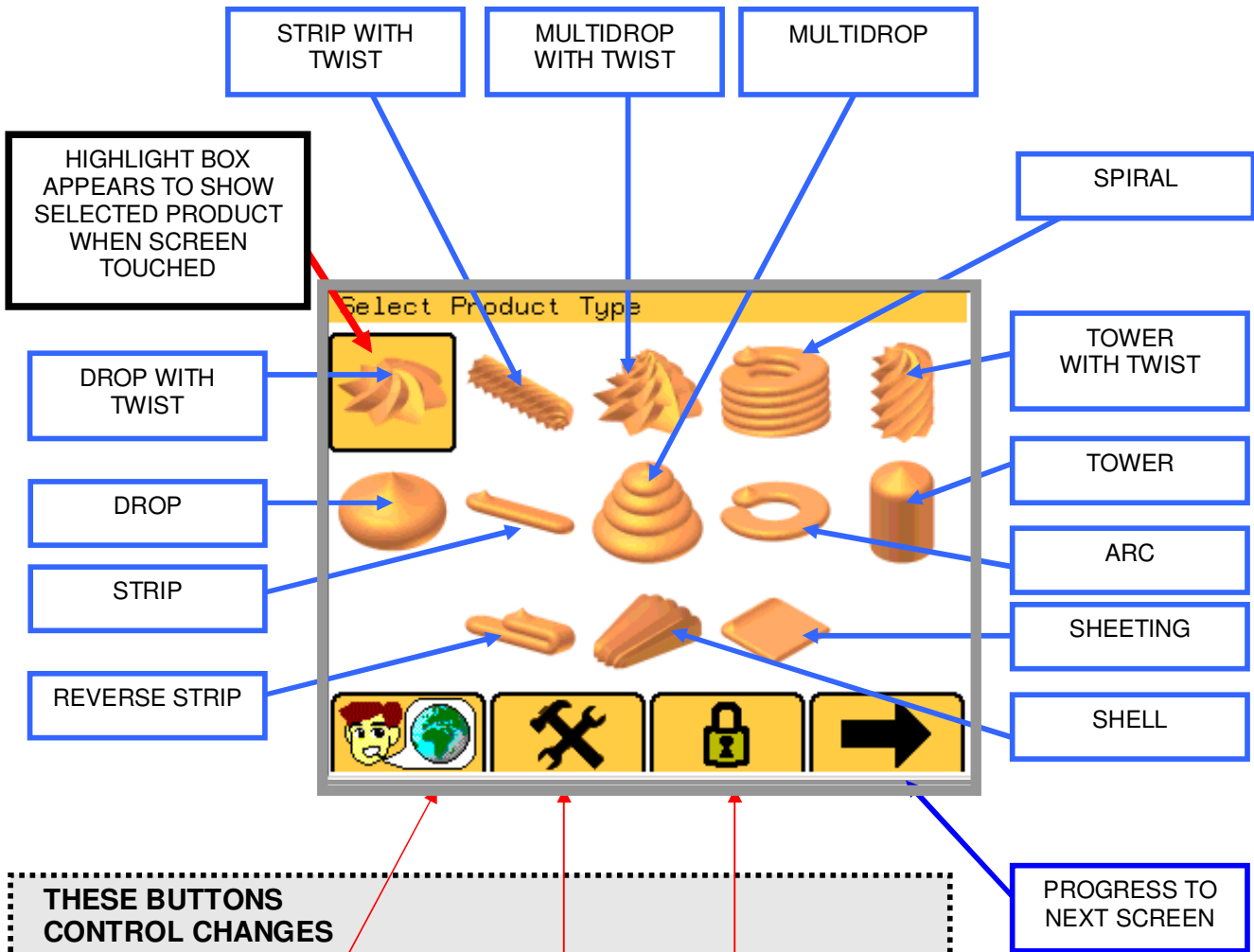

SELECT SAVED PRODUCT TYPE

OR CHOOSE EMPTY SLOT TO CREATE A NEW PROGRAM

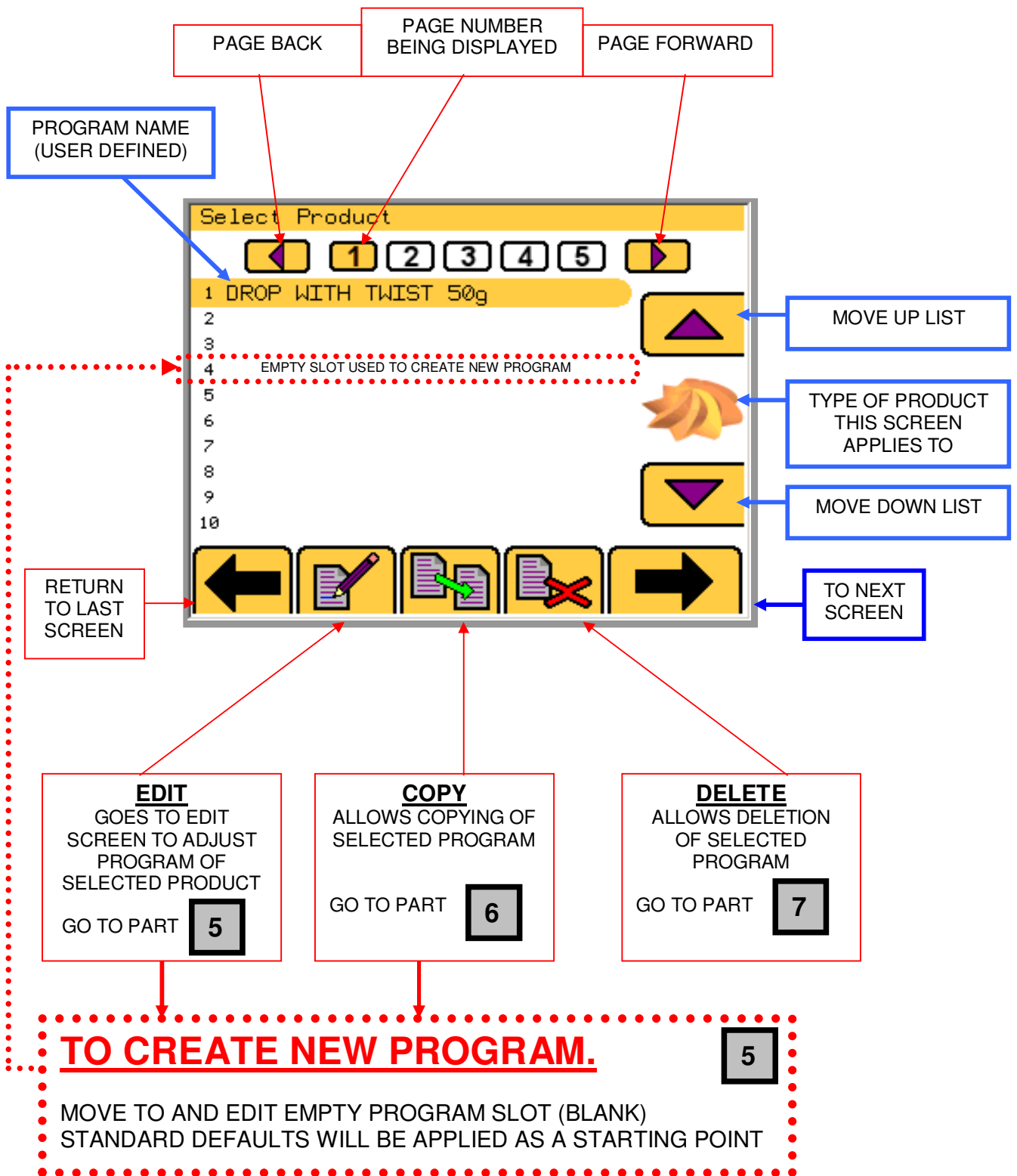

CONFIRM SETUP OF MACHINE

MACHINE MUST BE SET AS SHOWN ON THE SCREEN.
THEN PRESS CONFIRM BUTTON.

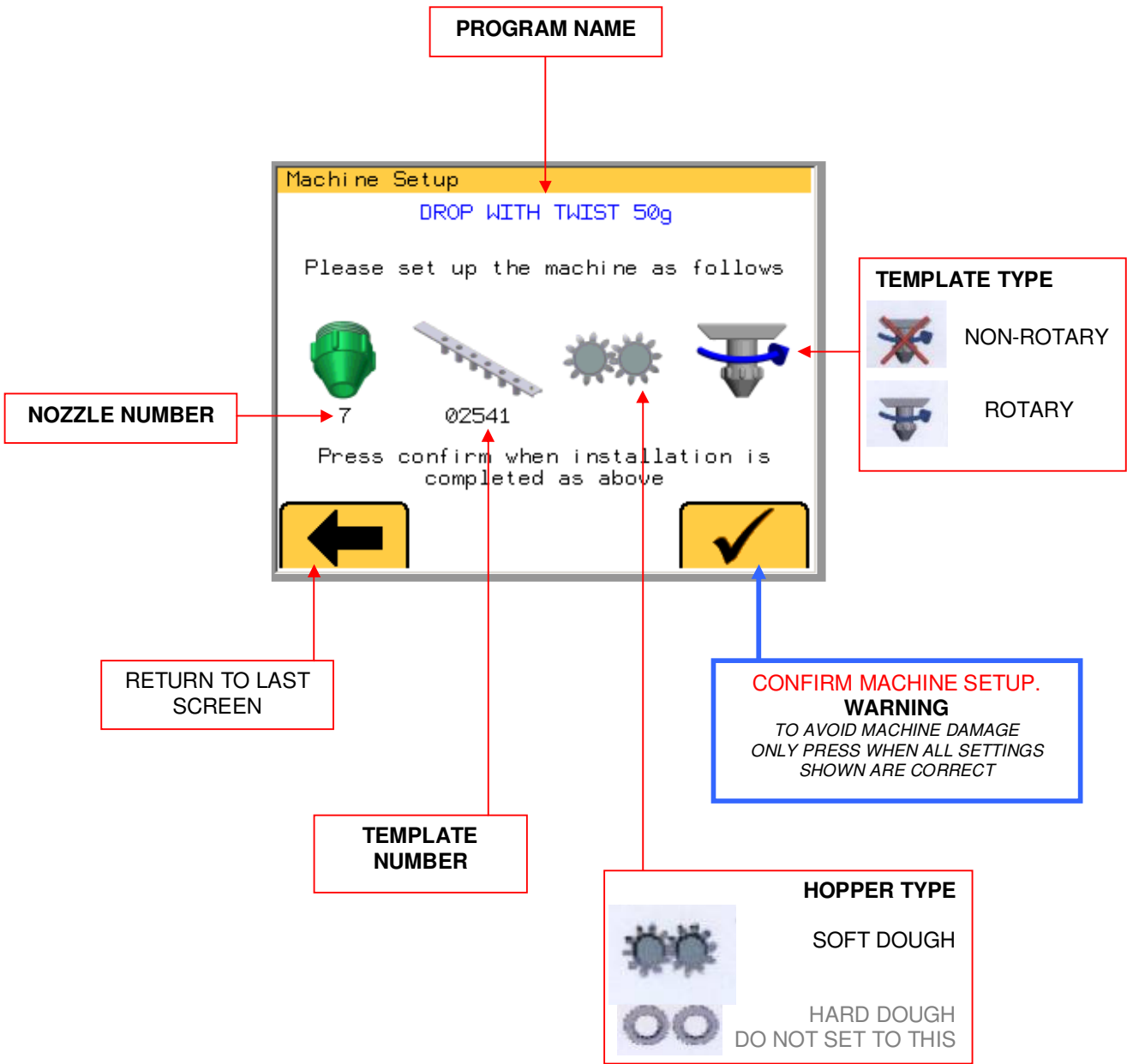

OPERATOR SCREEN

MACHINE IS SET AS SHOWN ON THE SCREEN.
THIS SCREEN CONTROLS THE ACTIONS REQUIRED BY THE OPERATOR.

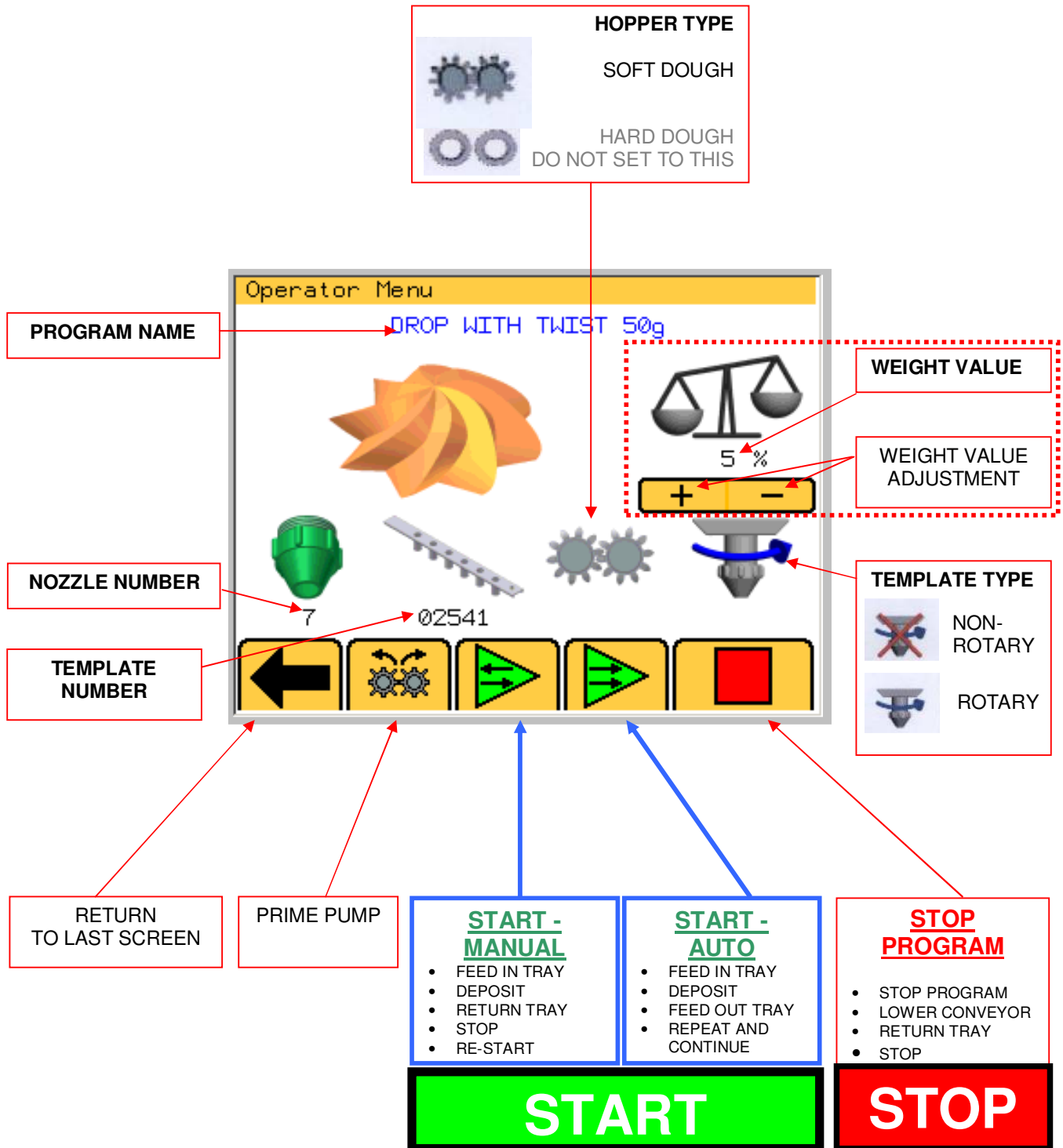

EDIT AND SAVE SCREEN

**EXAMPLE:
DROP WITH
TWIST**

PROGRAM NAME
MUST BE ENTERED TO
ALLOW PROGRAM TO SAVE

PRODUCT QUANTITY
THIS IS A SETTING NUMBER AND
DOES NOT INDICATE A MEASURE OF
ACTUAL VOLUME

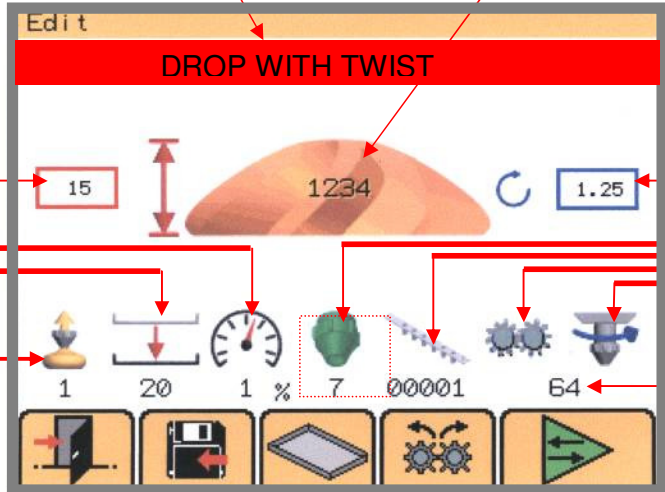

NOZZLE HEIGHT (mm)
ABOVE TRAY SURFACE

NOZZLE ROTATIONS
NUMBER OF TURNS
DURING A DEPOSIT CYCLE

EXIT THIS SCREEN



ENTER TRAY
SETUP
SCREEN
GO TO PART
5A

MAX HEIGHT FOR
HOPPER/TEMPLATE
COMBINATION

START
MANUAL MODE

PRIME PUMP
(SOFT DOUGH SHOWN)

SAVE EDITS

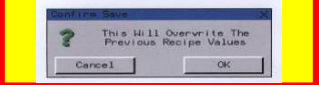

NOTE
A RED BACKGROUND TO ANY
SETTING MEANS THAT THE
VALUE SHOULD BE
CORRECTED

TEMPLATE TYPE
ROTARY
NON-ROTARY

SELECT HOPPER
SOFT DOUGH

TEMPLATE NUMBER
ENTER VIA KEYPAD
THAT APPEARS WHEN
PRESSED

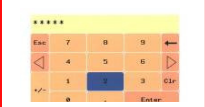

SUCK BACK
QUANTITY

TABLE
JOG DISTANCE (mm)

OVERALL
MACHINE SPEED
(% OF MAXIMUM)

CHOOSE NOZZLE TYPE

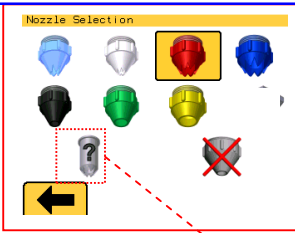

**EXAMPLE:
MULTIDROP WITH
TWIST**

**SETTING ERROR
INDICATOR**

BOXES TURN RED WHEN
INCORRECT SETTING
IS MADE

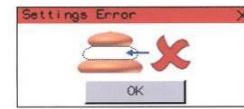

DEPOSIT QUANTITY
FOR EACH LAYER

NOZZLE HEIGHT (mm)
FOR EACH LAYER

NOZZLE HEIGHT (mm)
FROM TRAY SURFACE

NUMBER OF TURNS
FOR EACH LAYER
(-VE VALUES POSSIBLE)

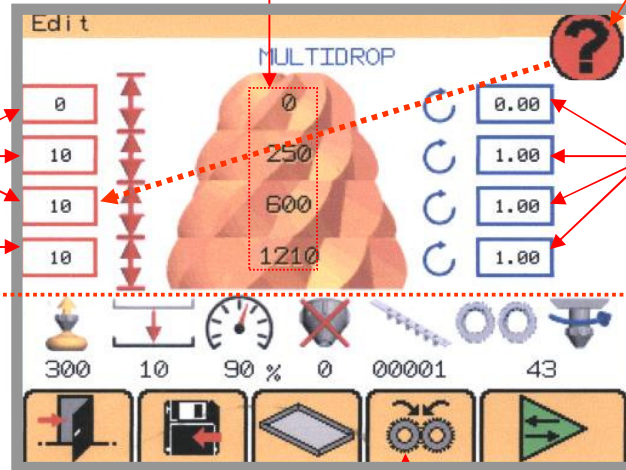

OTHER SETTING BUTTONS ARE
THE SAME AS LAST PAGE

PRIME PUMP
(HARD DOUGH SHOWN)

**EXAMPLE:
SHEETING / STRIP**

DEPOSIT QUANTITY
FOR BEGINNING OF
PRODUCT

DEPOSIT QUANTITY
FOR LENGTH

DEPOSIT QUANTITY
FOR END OF
PRODUCT
(-VE VALUES POSSIBLE)

NOZZLE HEIGHT
ABOVE TRAY
SURFACE

LENGTH (mm) OF
TRAY MOVEMENT

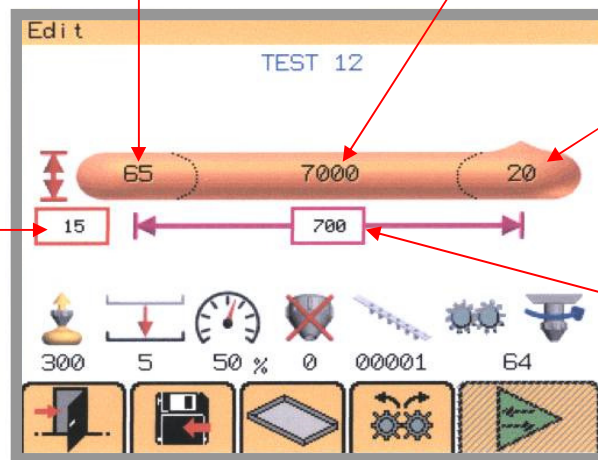

**EXAMPLE:
"C" SHAPE
(ARC)**

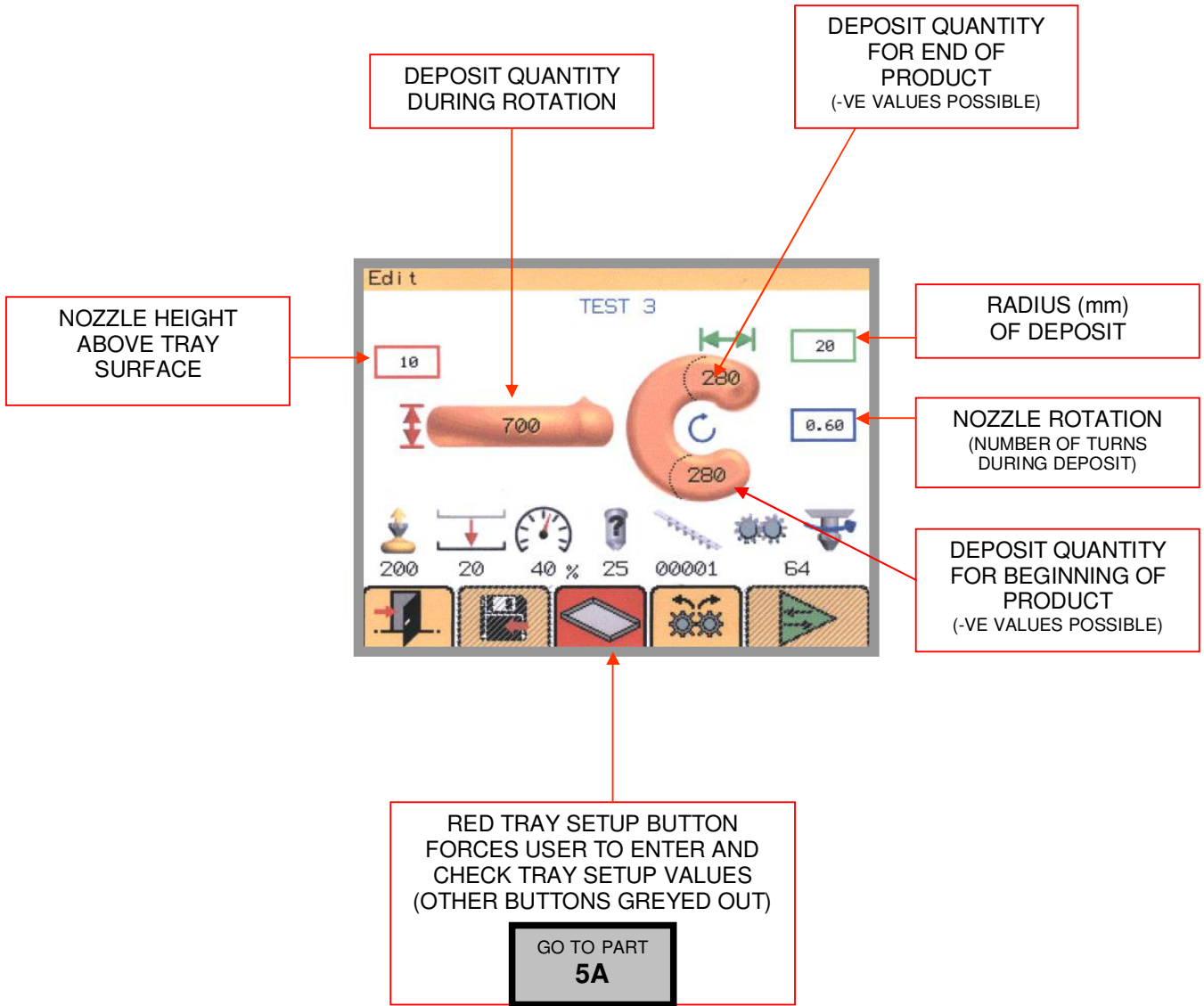

TRAY SETUP

5A

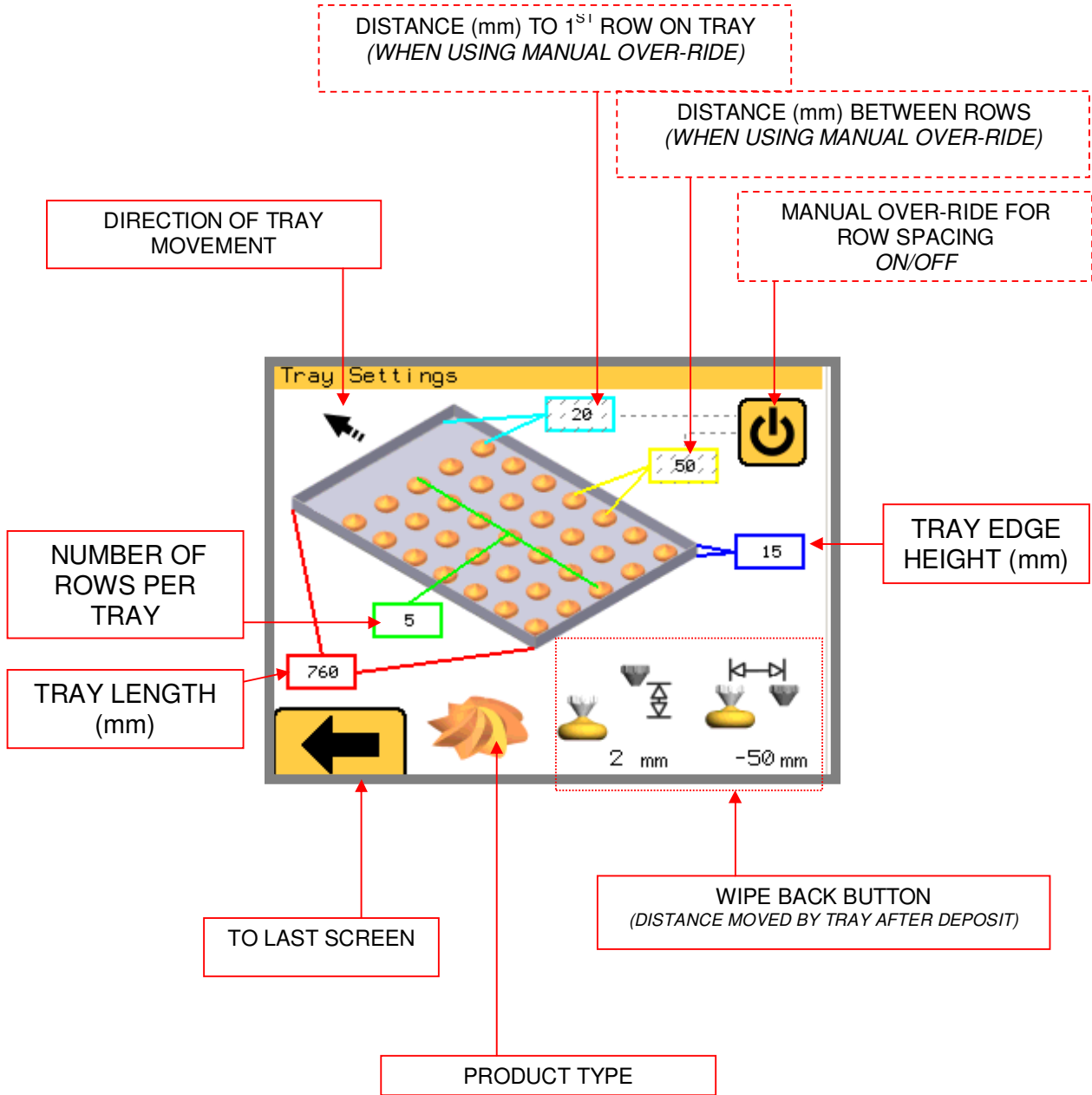
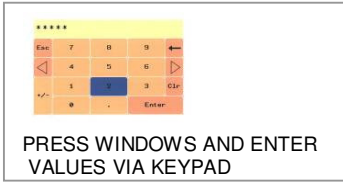

COPY

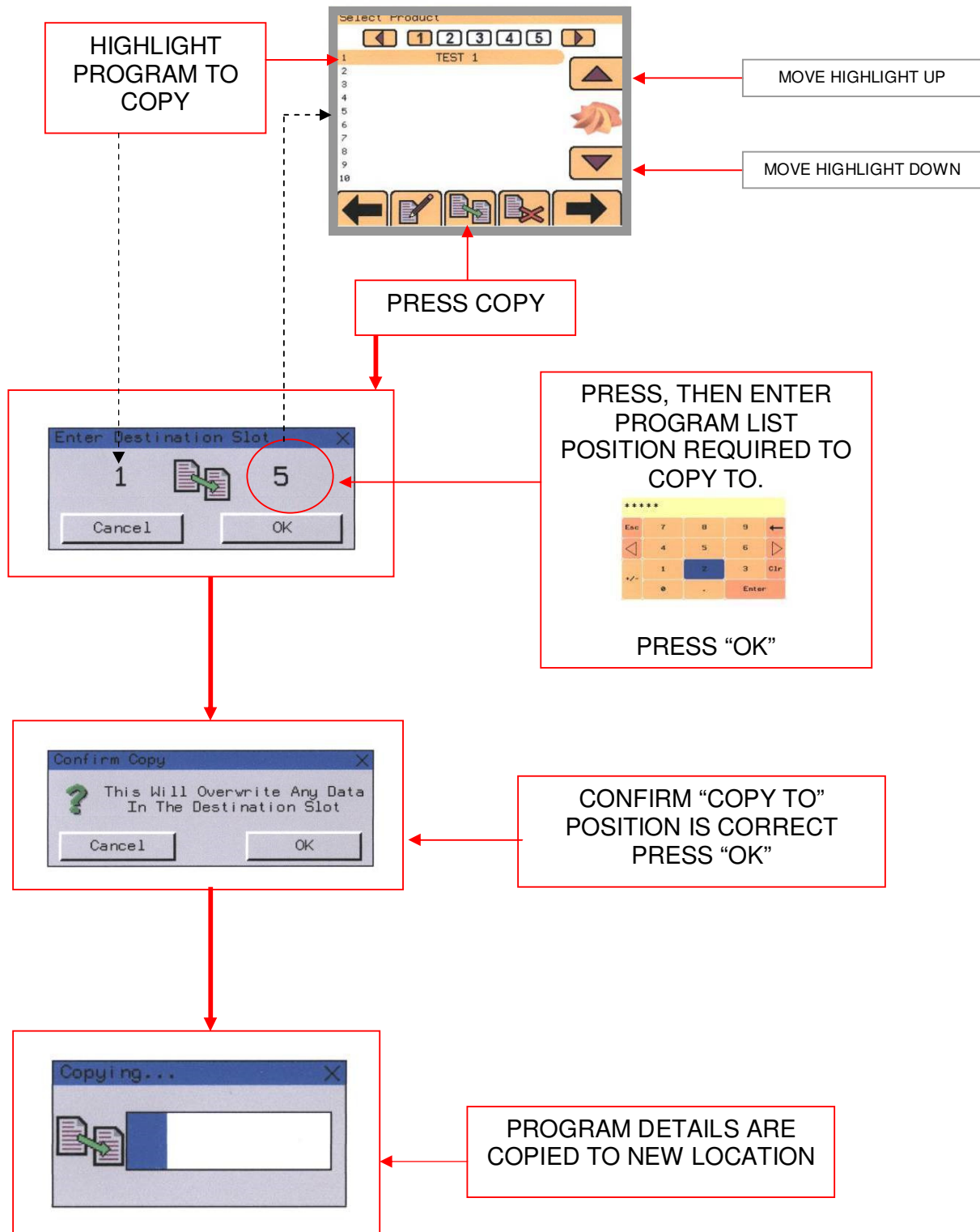

DELETE

7

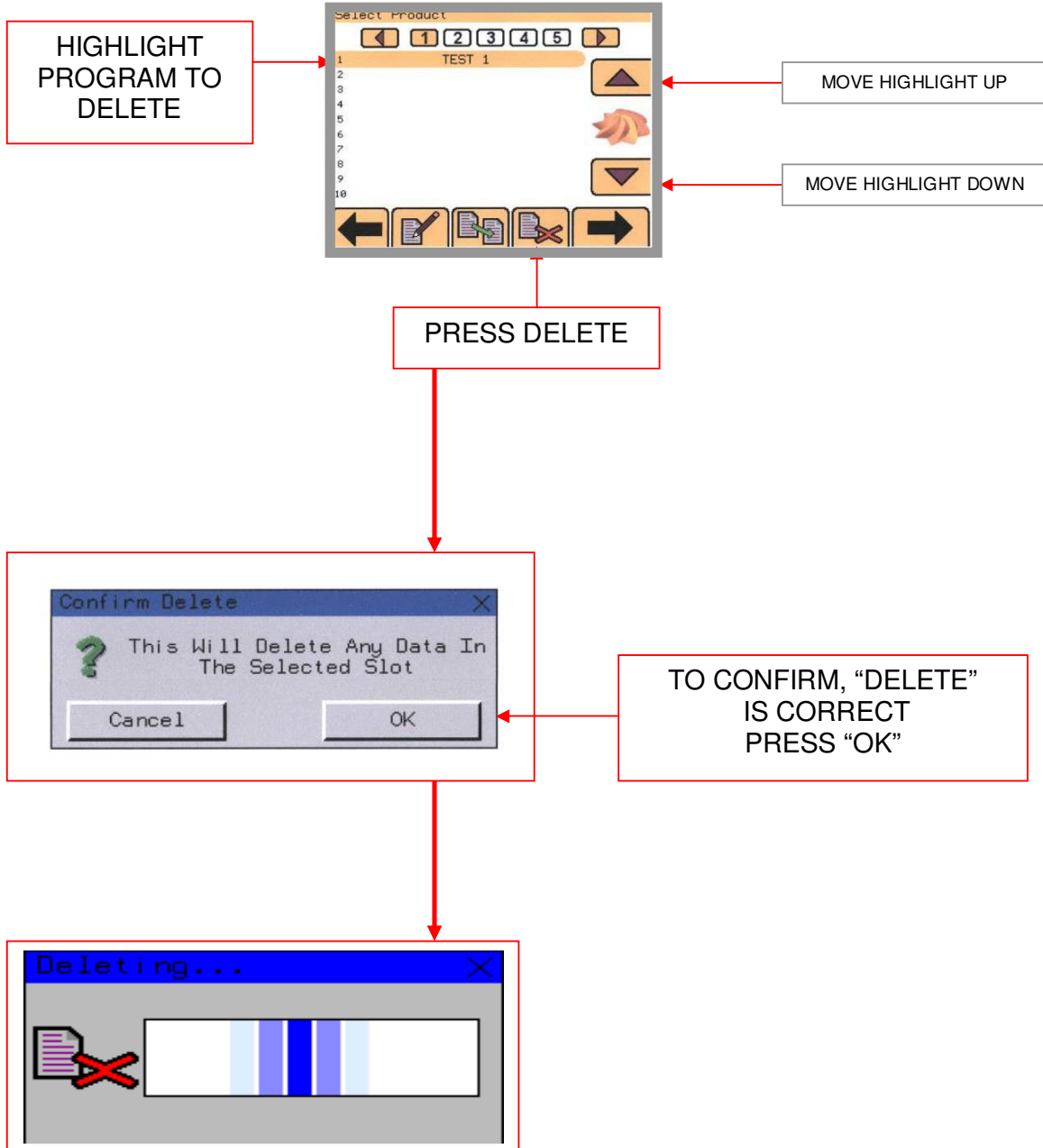

PASSWORDS

CAUTION
DO NOT ATTEMPT TO MAKE ADJUSTMENTS UNLESS YOU ARE FULLY AWARE OF THE RESULTS

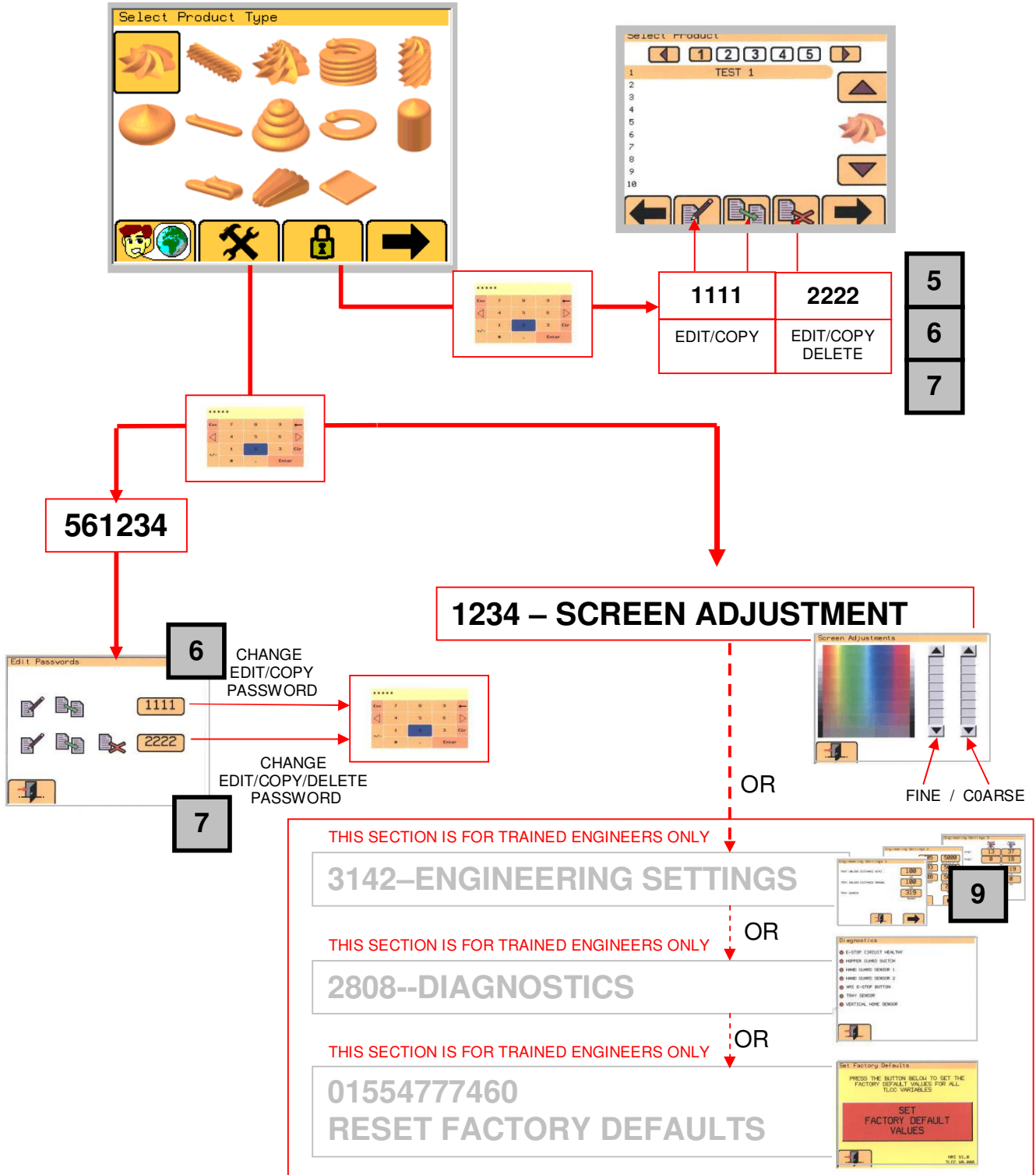

ENGINEERING SETTINGS (1)

THIS SECTION IS FOR TRAINED ENGINEERS ONLY

The screenshot shows the 'Engineering Settings 1' screen. It features two main settings: 'TRAY UNLOAD DISTANCE MANUAL' set to 100 MM and 'TRAY SEARCH' set to 319 MM Speed. At the bottom, there are two navigation buttons: one with a left-pointing arrow and a tray icon, and another with a right-pointing arrow. Two callout boxes provide detailed information: one for the 100 MM setting, explaining it's the distance the leading edge of the tray is brought back past the sensor in manual mode; another for the 319 MM Speed setting, explaining it's the speed value fed up to the tray sensor. Two small inset images show a numeric keypad with the 'Enter' key highlighted.

IN MANUAL MODE:
DISTANCE THAT THE LEADING EDGE
OF THE TRAY IS BROUGHT BACK
PASSED THE TRAY SENSOR, WHEN
RETURNING TO OPERATOR

TRAY UNLOAD DISTANCE MANUAL
100
MM

TRAY SEARCH
319
MM
Speed

SPEED VALUE THAT TRAY IS
FED UP TO TRAY SENSOR

EXIT
THIS SCREEN

GO TO NEXT SCREEN
ENGINEERING SETTING 2
(NEXT PAGE)

CAUTION

DO NOT ATTEMPT TO MAKE ADJUSTMENTS UNLESS YOU ARE FULLY AWARE OF THE RESULTS

ENGINEERING SETTINGS (2)

THIS SECTION IS FOR TRAINED ENGINEERS ONLY

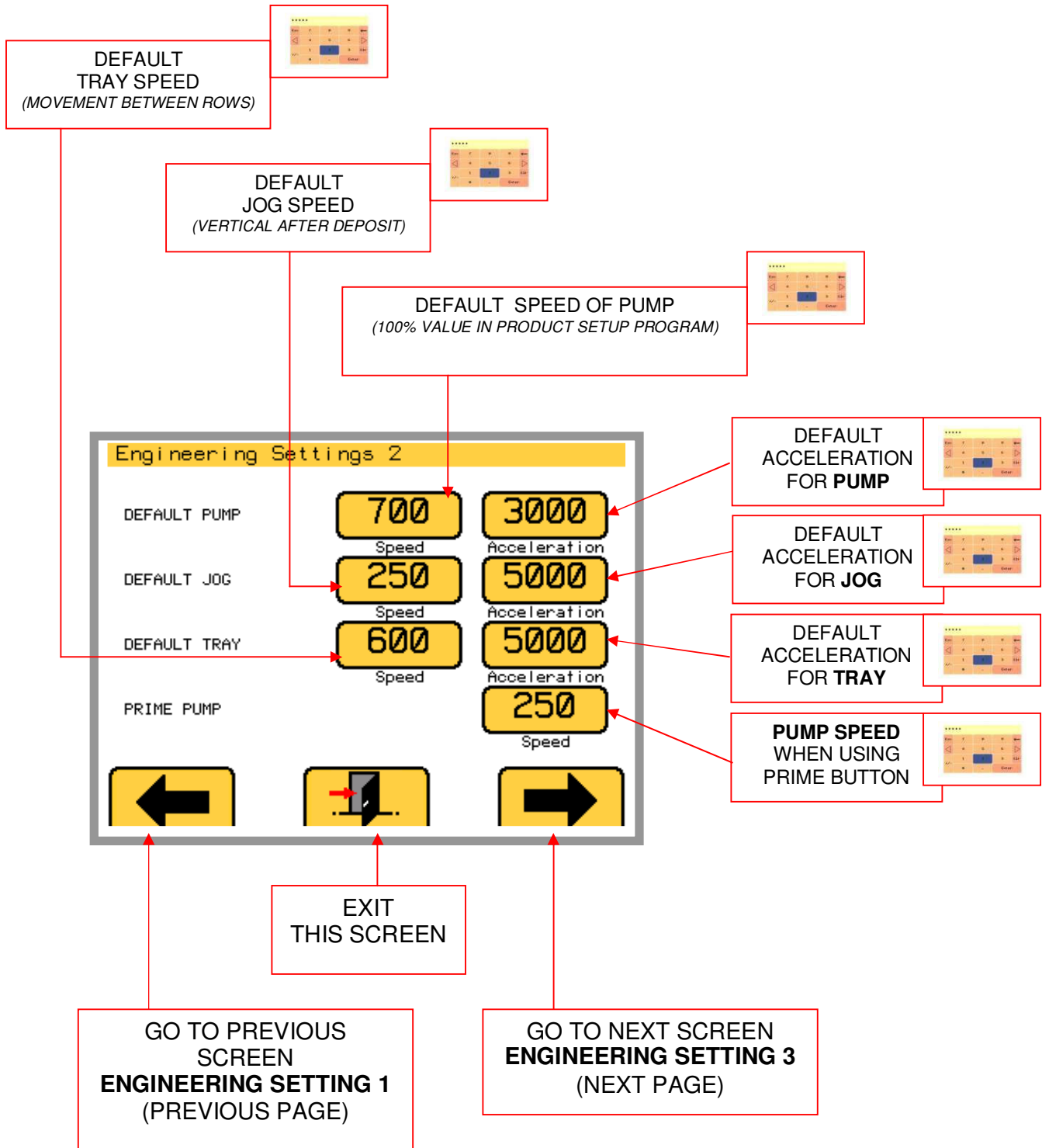

CAUTION

DO NOT ATTEMPT TO MAKE ADJUSTMENTS UNLESS YOU ARE FULLY AWARE OF THE RESULTS

ENGINEERING SETTINGS (3)

THIS SECTION IS FOR TRAINED ENGINEERS ONLY

The screenshot shows the 'Engineering Settings 3' screen with the following settings:

- HARD DOUGH OFFSET: 13
- SOFT DOUGH OFFSET: 0
- HARD DOUGH CENTRE LINE OFFSET: -19
- SOFT DOUGH CENTRE LINE OFFSET: 0

Callouts provide detailed explanations for these values:

- OFFSET HEIGHT VALUE (mm) HARD DOUGH HOPPER NON-ROTARY TEMPLATE:** Points to the value 13.
- OFFSET HEIGHT VALUE (mm) HARD DOUGH HOPPER ROTARY TEMPLATE:** Points to the value 37.
- OFFSET HEIGHT VALUE (mm) SOFT DOUGH HOPPER ROTARY TEMPLATE:** Points to the value 16.
- OFFSET HEIGHT VALUE (mm) SOFT DOUGH HOPPER NON-ROTARY TEMPLATE:** Points to the value 0.
- DISTANCE (mm) FROM HARD DOUGH HOPPER DEPOSITING CENTRELINE TO TRAY EDGE DETECTION POINT (USED IN ROW SPACING CALCULATIONS):** Points to the value -19.
- DISTANCE (mm) FROM SOFT DOUGH HOPPER DEPOSITING CENTRELINE TO TRAY EDGE DETECTION POINT (USED IN ROW SPACING CALCULATIONS):** Points to the value 0.

Navigation and control callouts:

- GO TO PREVIOUS SCREEN ENGINEERING SETTING 2 (PREVIOUS PAGE):** Points to the left arrow button.
- EXIT THIS SCREEN:** Points to the central icon button.
- GO TO NEXT SCREEN ENGINEERING SETTING 4 (NEXT PAGE):** Points to the right arrow button.

WARNING: OFFSET HEIGHT VALUE IS FACTORY SET AND SHOULD NOT BE CHANGED UNLESS INSTRUCTED TO DO SO. DAMAGE TO THE MACHINE COULD OCCUR.

CAUTION
DO NOT ATTEMPT TO MAKE ADJUSTMENTS UNLESS YOU ARE FULLY AWARE OF THE RESULTS

ENGINEERING SETTINGS (4)

THIS SECTION IS FOR TRAINED ENGINEERS ONLY

GEARBOX RATIOS

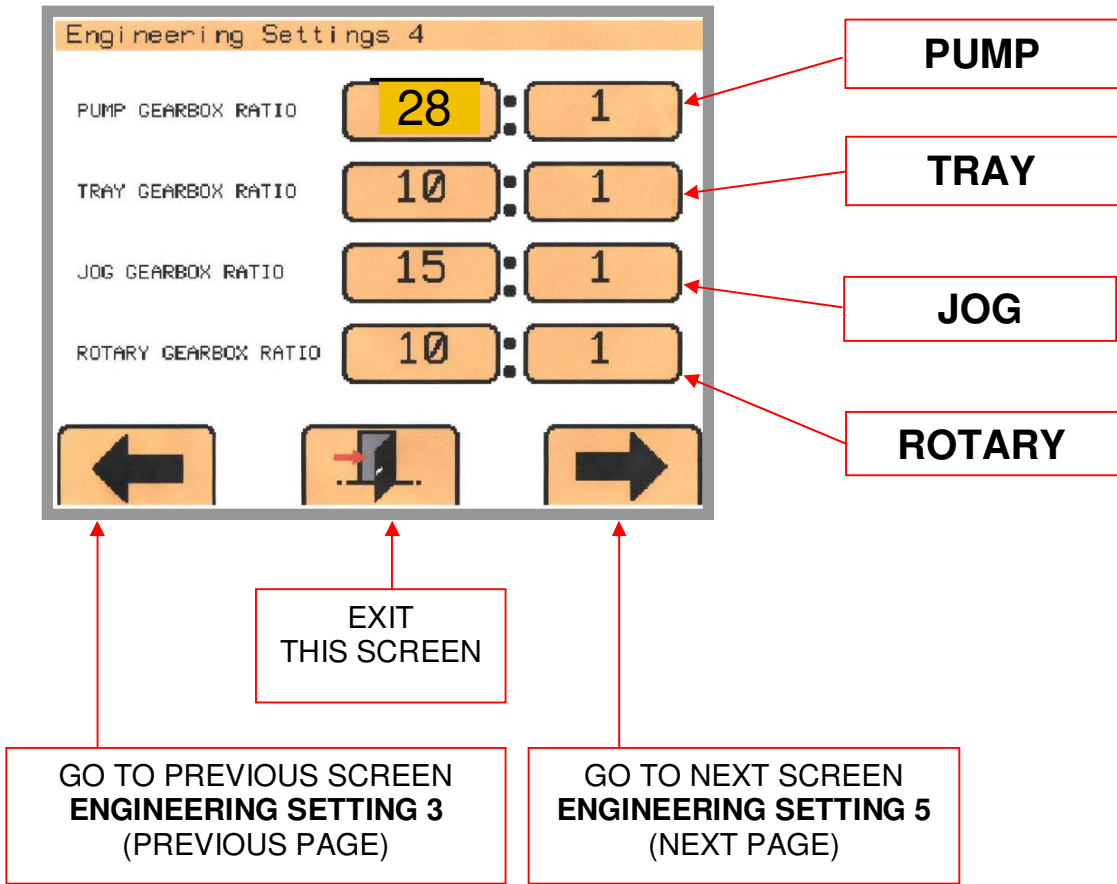

CAUTION

DO NOT ATTEMPT TO MAKE ADJUSTMENTS UNLESS YOU ARE FULLY AWARE OF THE RESULTS

ENGINEERING SETTINGS (5)

THIS SECTION IS FOR TRAINED ENGINEERS ONLY

WIPE BACK DEFAULT SETTINGS (SEE 5A)

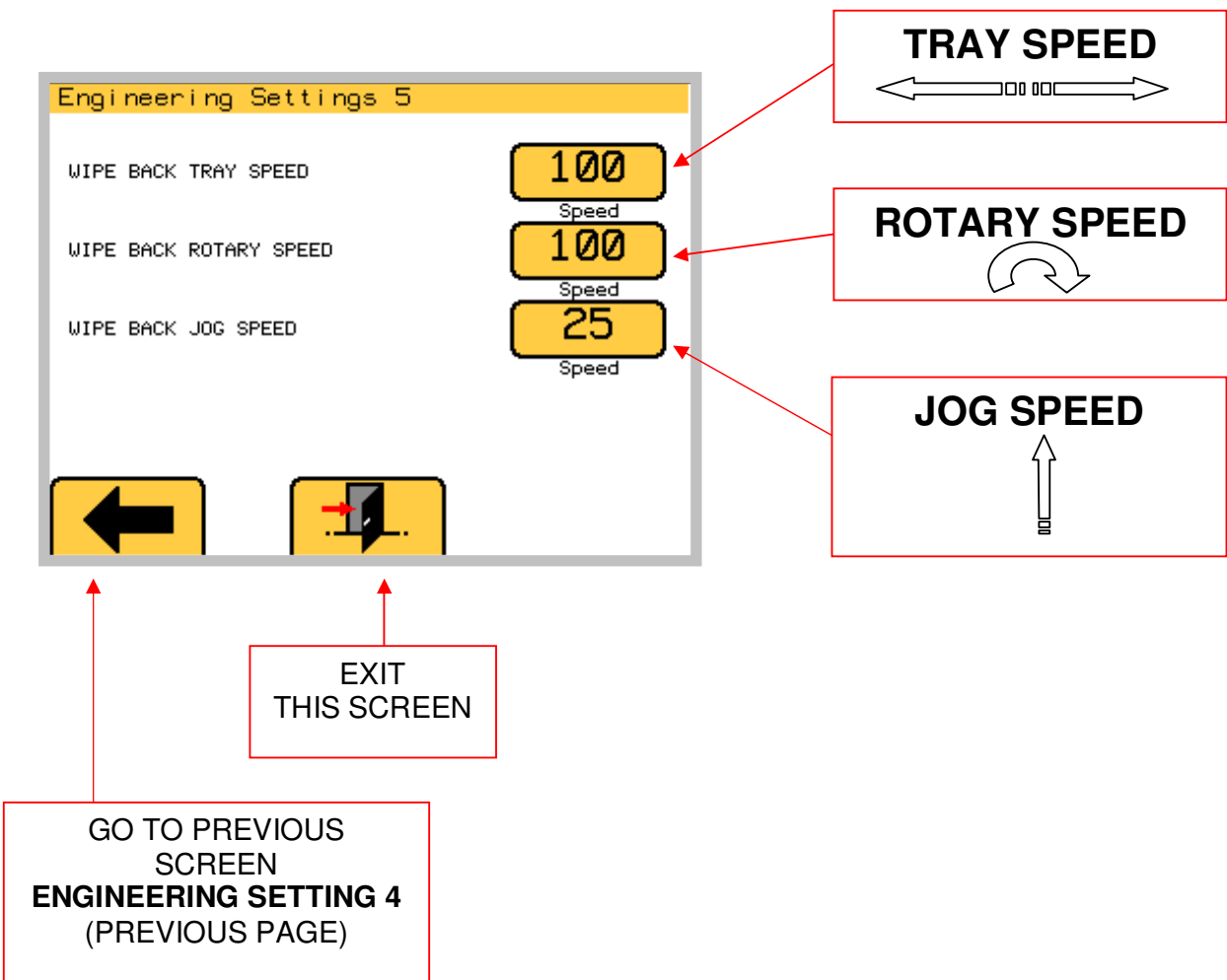

CAUTION

DO NOT ATTEMPT TO MAKE ADJUSTMENTS UNLESS YOU ARE FULLY AWARE OF THE RESULTS

FAULT INFORMATION SCREENS

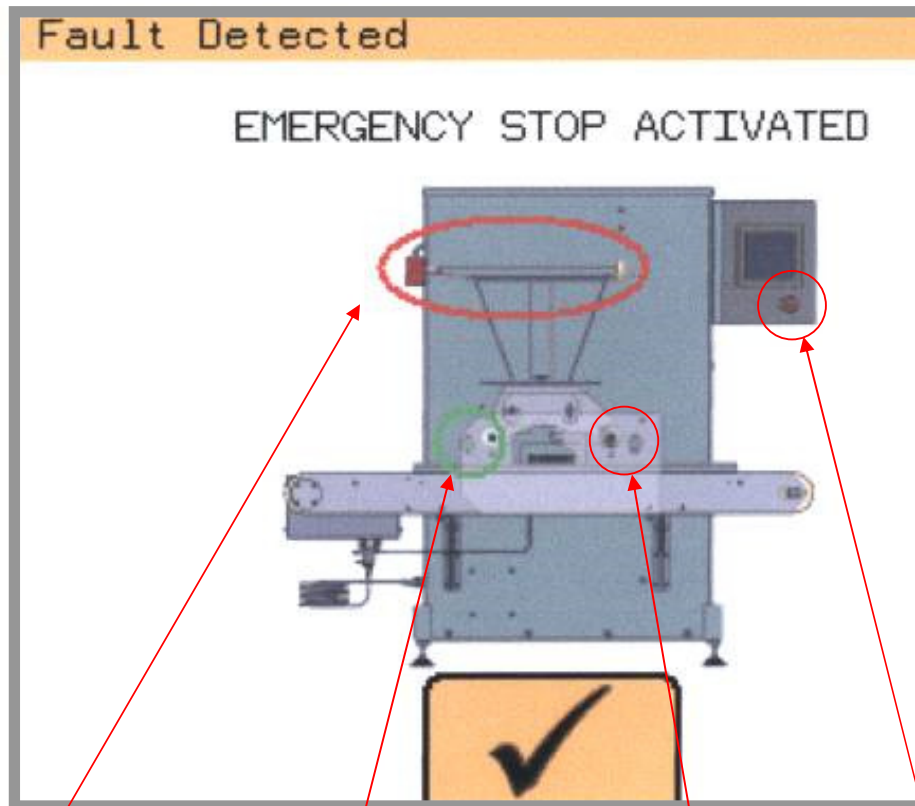

HOPPER COVER

SAFETY BEAM

SAFETY BEAM

STOP BUTTON

THIS SCREEN INDICATES A FAULT CONDITION IN THE SAFETY AREAS.

WHEN **RED**, CLOSE COVER OR CLEAR OBSTRUCTIONS TO CLEAR FAULT.
WHEN INDICATOR GOES **GREEN**, FAULT HAS BEEN CORRECTED AT THAT POSITION.

PRESS  BUTTON TO CLEAR SCREEN

IF THE FOLLOWING SCREEN APPEARS, CHECK THAT THE TABLE MOVEMENT ETC. IS NOT JAMMED WITH SOMETHING. IF IT IS, CLEAR THE OBSTRUCTION AND PRESS  TO PROCEED.

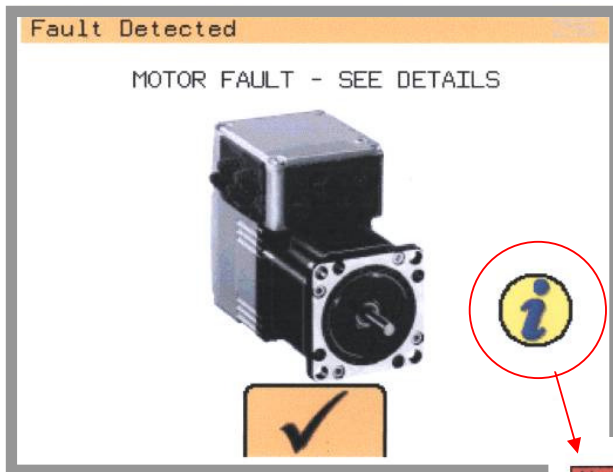

PRESS THIS BUTTON IF MORE INFORMATION IS REQUIRED AS TO WHICH MOTOR IS AT FAULT

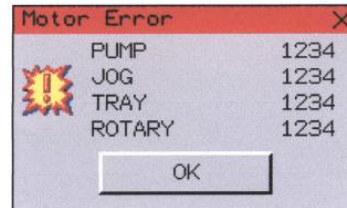

IF THE FAULT IS NOT OBVIOUS AND NOT ABLE TO BE CLEARED SAFELY, A SUITABLY TRAINED ENGINEER SHOULD BE CALLED

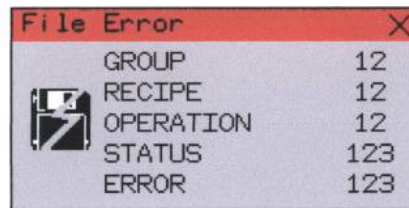

ERROR WHEN LOADING/SAVING RECIPE DATA TO HMI STORAGE CARD
PLEASE CONTACT SERVICE DEPT. / ENGINEER IF PROBLEM PERSISTS

11.0 MAINTENANCE

Omega Touch

Under most conditions the machine only needs to be kept clean and used as instructed in this manual.



**WARNING: DO NOT UNDER ANY CIRCUMSTANCES
USE A WATER HOSE OR PRESSURE WASHER TO
CLEAN THIS MACHINE.**

Mono Omega Touch

Check and Maintenance Schedule

Operation	Daily	weekly	3 monthly	Yearly
Clean depositor as per instructions in manual	*			
Check condition of supply lead and plug	*			
check fit of guards	*			
Clean under conveyor belts		*		
Check hopper seals		*		
Check end cap seals		*		
Check condition and tension of conveyor, adjust / replace as required			*	
Check end cap bearings			*	
check alignment of sensors on guards			*	
Check tray sensor is secure			*	
Check condition of idle roller bearings				*
Check condition of drive shaft bearings				*
Check condition and tension of chain and grease as required				*
Grease slides as required				*
adjust eccentric guide rollers as required				*
adjust concentric guide rollers as required				*
Check and grease all slide plates as required				*
Check all motor mounts are tight				*
inspect electrical connections and tighten as required				*

Under no circumstances should maintenance or cleaning of this machine be done with the power connected

12.0 SPARES AND SERVICE

Omega Touch

If a fault arises, please do not hesitate to contact the
Customer Service Department, quoting the **machine serial number**
found on the silver information plate of the machine and on the front cover of this manual

UK SERVICE, SPARES and OVERSEAS SUPPORT:



Queensway
Swansea West Industrial Estate
Swansea. SA5 4EB UK

email: spares@monoequip.com
Web site: www.monoequip.com

Spares Tel. +44(0)1792 564039
Main Tel. +44(0)1792 561234
Fax. 01792 561016

BASE MACHINE SPARES LIST

Omega TOUCH

Spares Item Description	Mono Part No.	Qty Req. per M/C
Deposit Gearbox	A900-11-095	1
Jog Gearbox	A900-11-092	1
Rotary Gearbox	A900-11-091	1
Tray Gearbox	A900-11-091	1
Concentric Guide Roller	A900-06-274	2
Eccentric Guide Roller	A900-06-273	2
Slide Plate	078-03-00016	2
Jog Drive Chain	A900-08-066	1
Simplex Sprocket 16T 1/2" Pitch	A900-07-071	1
Idler Sprocket 16T 1/2" Pitch	A900-07-072	1
Circlip-Ext Metric 14mm Dia	A900-01-280	1
Circlip-Ext Metric 24mm Dia	A900-01-193	1
Drive Shaft – Hopper	078-03-00015	1
Rotary Drive Shaft	078-03-00011	1
Drive Gear - Rotary Template	078-03-00010	1
Lip Seal (Rotary Drive Shaft)	A900-12-075	1
Lip Seal (Deposit Drive Shaft)	A900-12-079	1
End Guard	078-11-00001	1
Retainer – End Guard	078-11-00002	2
Spacer - 450/580mm Hopper	078-11-00003	1
Spacer – 400mm	078-11-00004	1
Seal-Rear Cover	A900-25-309	1

ELECTRICAL COMPONENT LAYOUT PARTS

Omega TOUCH

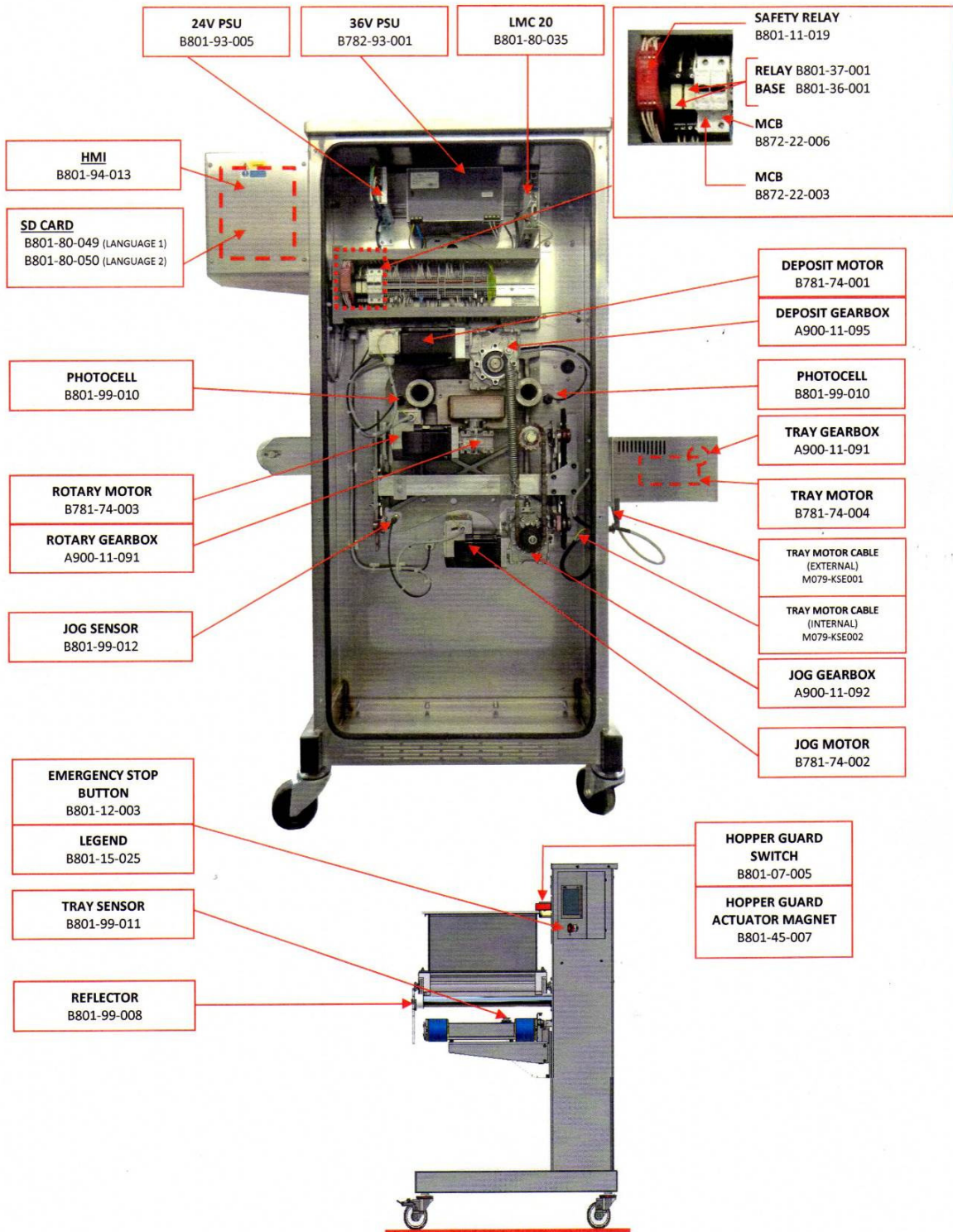

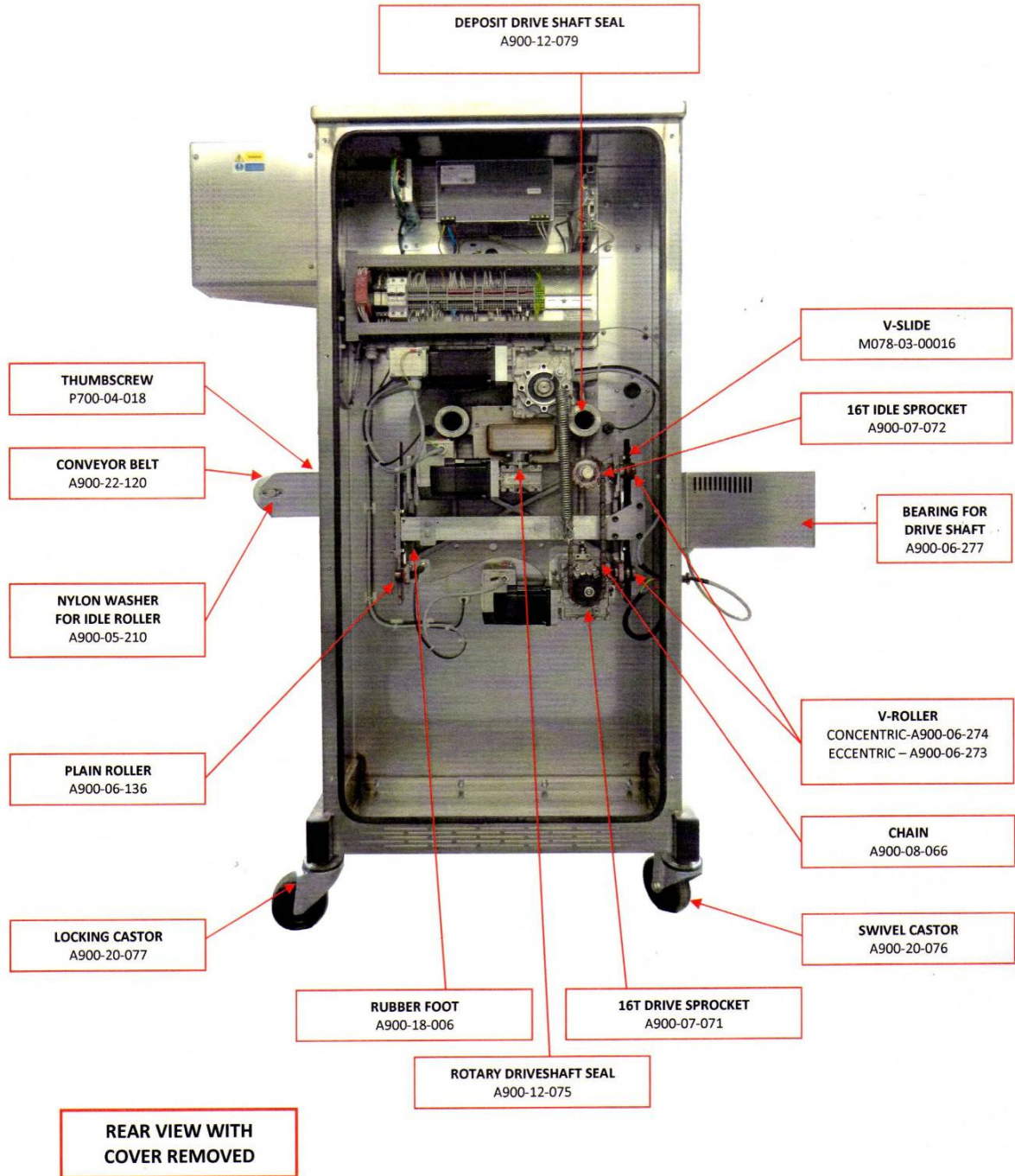

SOFT DOUGH HOPPER PARTS

Omega and Omega PLUS

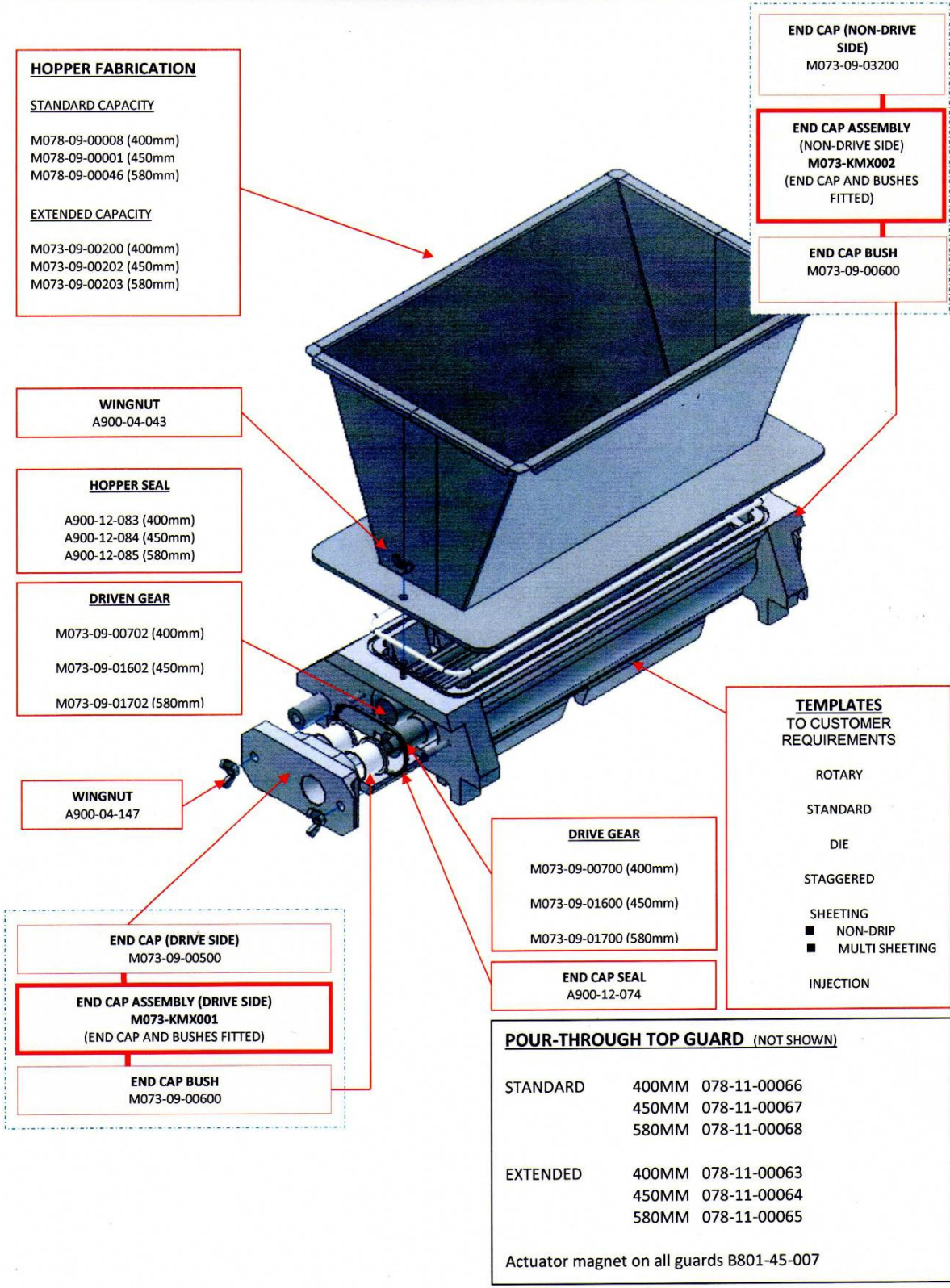

HOPPER FABRICATION

STANDARD CAPACITY

M078-09-00008 (400mm)
M078-09-00001 (450mm)
M078-09-00046 (580mm)

EXTENDED CAPACITY

M073-09-00200 (400mm)
M073-09-00202 (450mm)
M073-09-00203 (580mm)

END CAP (NON-DRIVE SIDE)
M073-09-03200

END CAP ASSEMBLY (NON-DRIVE SIDE)
M073-KMX002
(END CAP AND BUSHES FITTED)

END CAP BUSH
M073-09-00600

WINGNUT
A900-04-043

HOPPER SEAL

A900-12-083 (400mm)
A900-12-084 (450mm)
A900-12-085 (580mm)

DRIVEN GEAR

M073-09-00702 (400mm)
M073-09-01602 (450mm)
M073-09-01702 (580mm)

WINGNUT
A900-04-147

END CAP (DRIVE SIDE)
M073-09-00500

END CAP ASSEMBLY (DRIVE SIDE)
M073-KMX001
(END CAP AND BUSHES FITTED)

END CAP BUSH
M073-09-00600

DRIVE GEAR

M073-09-00700 (400mm)
M073-09-01600 (450mm)
M073-09-01700 (580mm)

END CAP SEAL
A900-12-074

TEMPLATES TO CUSTOMER REQUIREMENTS

ROTARY

STANDARD

DIE

STAGGERED

SHEETING

■ NON-DRIP

■ MULTI SHEETING

INJECTION

POUR-THROUGH TOP GUARD (NOT SHOWN)

STANDARD	400MM	078-11-00066
	450MM	078-11-00067
	580MM	078-11-00068
EXTENDED	400MM	078-11-00063
	450MM	078-11-00064
	580MM	078-11-00065

Actuator magnet on all guards B801-45-007



13.0 ELECTRICAL INFORMATION TOUCH VERSION

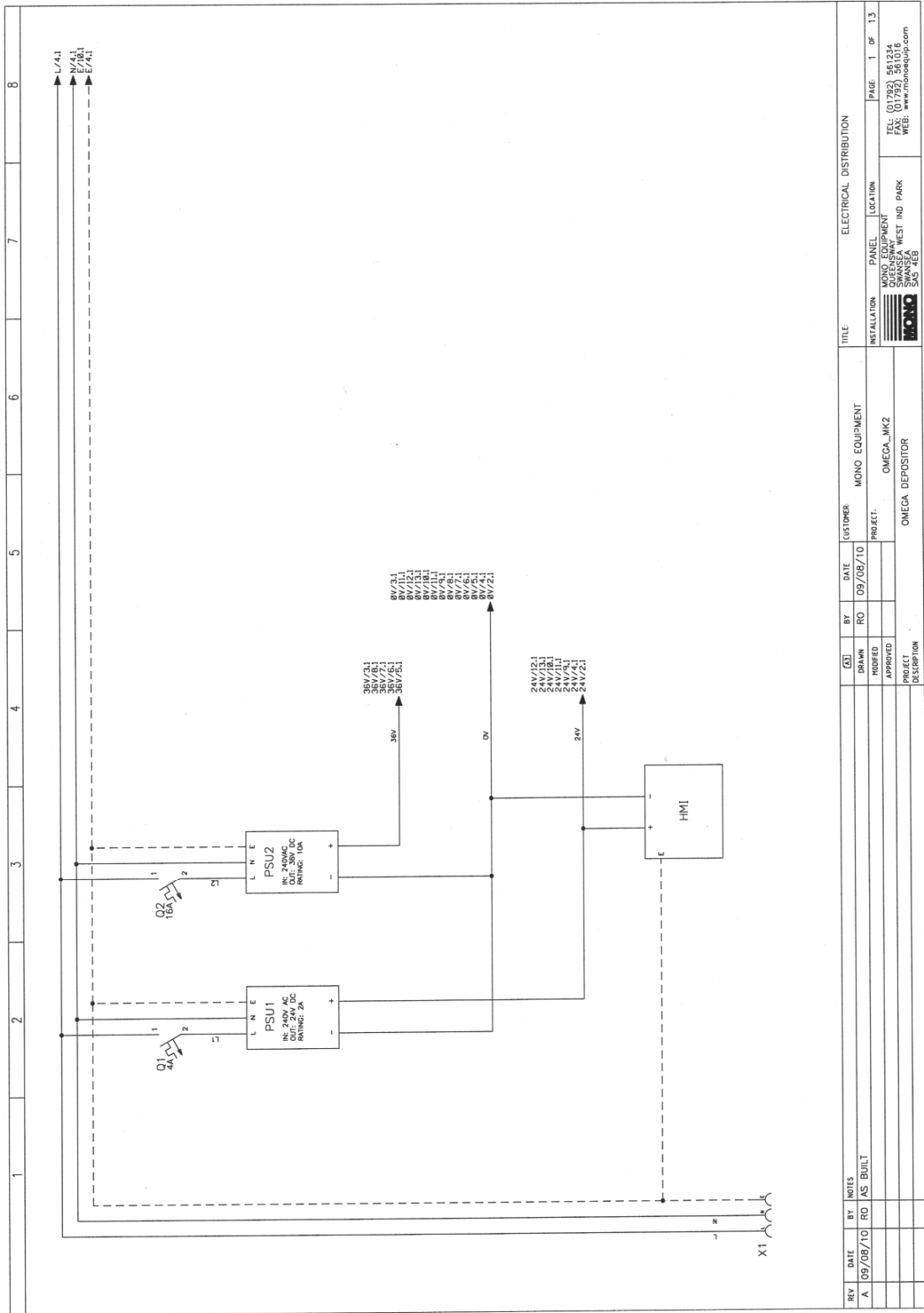

REV	DATE	BY	NOTES	TITLE			
A	09/08/10	RO	AS BUILT	INSTALLATION	PANEL	LOCATION	ELECTRICAL DISTRIBUTION
				MONO EQUIPMENT			PAGE 1 OF 1.3
				OMEGA_MK2			MONO EQUIPMENT
				OMEGA DEPOSITOR			SWANSEA WEST IND PARK
				PROJECT DESCRIPTION			TEL: (01792) 561234
							FAX: (01792) 561016
							WEB: www.monoequip.com

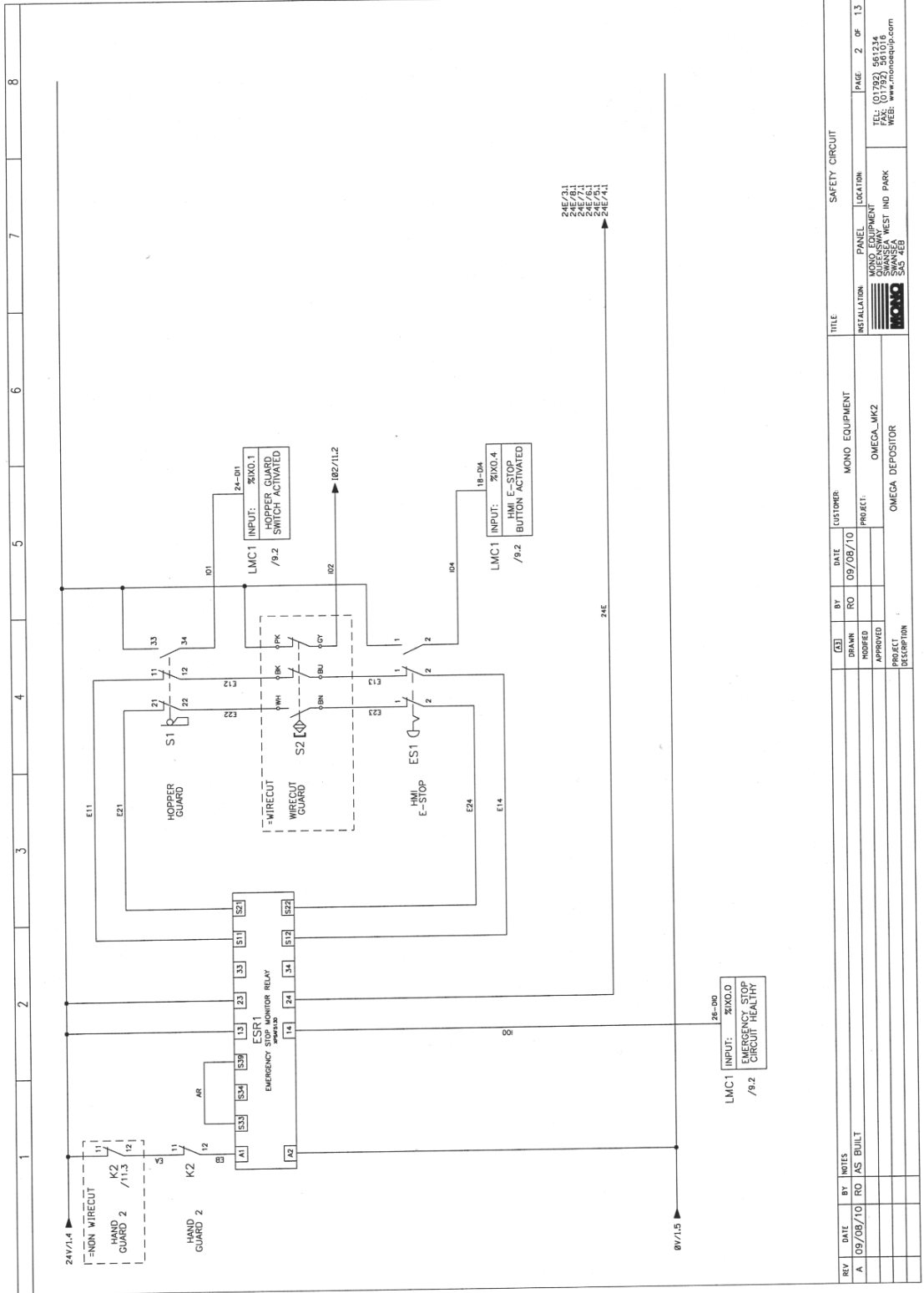

REV	DATE	BY	NOTES	DATE	BY	DATE	CUSTOMER	TITLE
A	09/08/10	RO	AS BUILT	09/08/10	RO	09/08/10	MONO EQUIPMENT	SAFETY CIRCUIT
							PROJECT: OMEGA_LM2	INSTALLATION: MONO EQUIPMENT
							OMEGA DEPOSITOR	LOCATION: SIMONSEN WEST IND PARK
								PANEL: MONO EQUIPMENT
								MONO EQUIPMENT
								TEL: (01792) 561234
								FAX: (01792) 561010
								WEB: www.monotech.pl.com

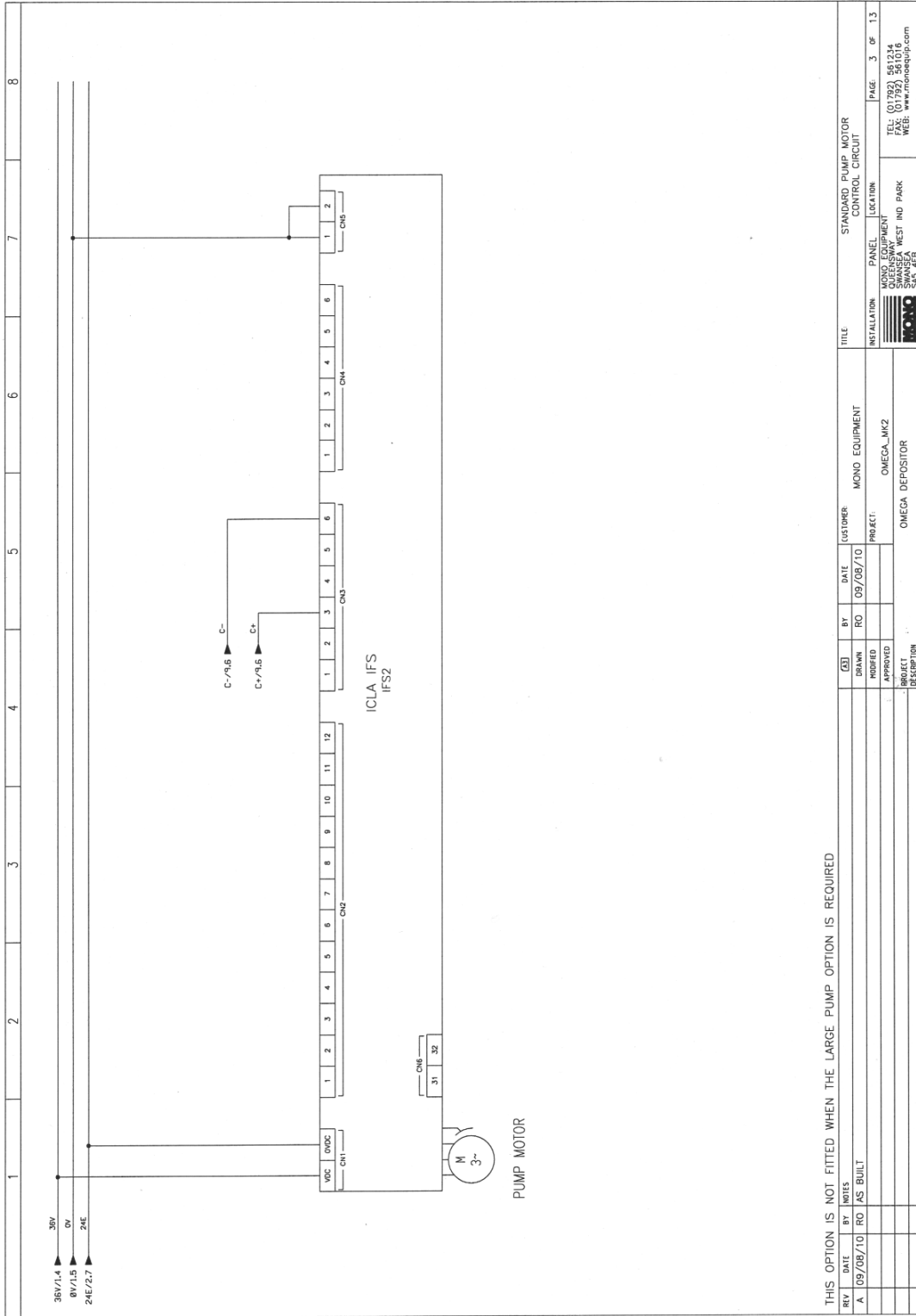

THIS OPTION IS NOT FITTED WHEN THE LARGE PUMP OPTION IS REQUIRED

REV	DATE	BY	DATE	BY	DATE	BY	DATE	BY	DATE	TITLE
A	09/08/10	RO	09/08/10	RO	09/08/10	RO	09/08/10	RO	09/08/10	STANDARD PUMP MOTOR CONTROL CIRCUIT
										INSTALLATION
										PANEL LOCATION
										MONO EQUIPMENT
										OMEGA_MK2
										PROJECT
										OMEGA DEPOSITOR
										MONO EQUIPMENT
										304-4EB
										WEST IND PARK
										SWANSEA
										TEL: (01792) 561016
										FAX: (01792) 561016
										WEB: www.monoequip.com
										PAGE 3 OF 13

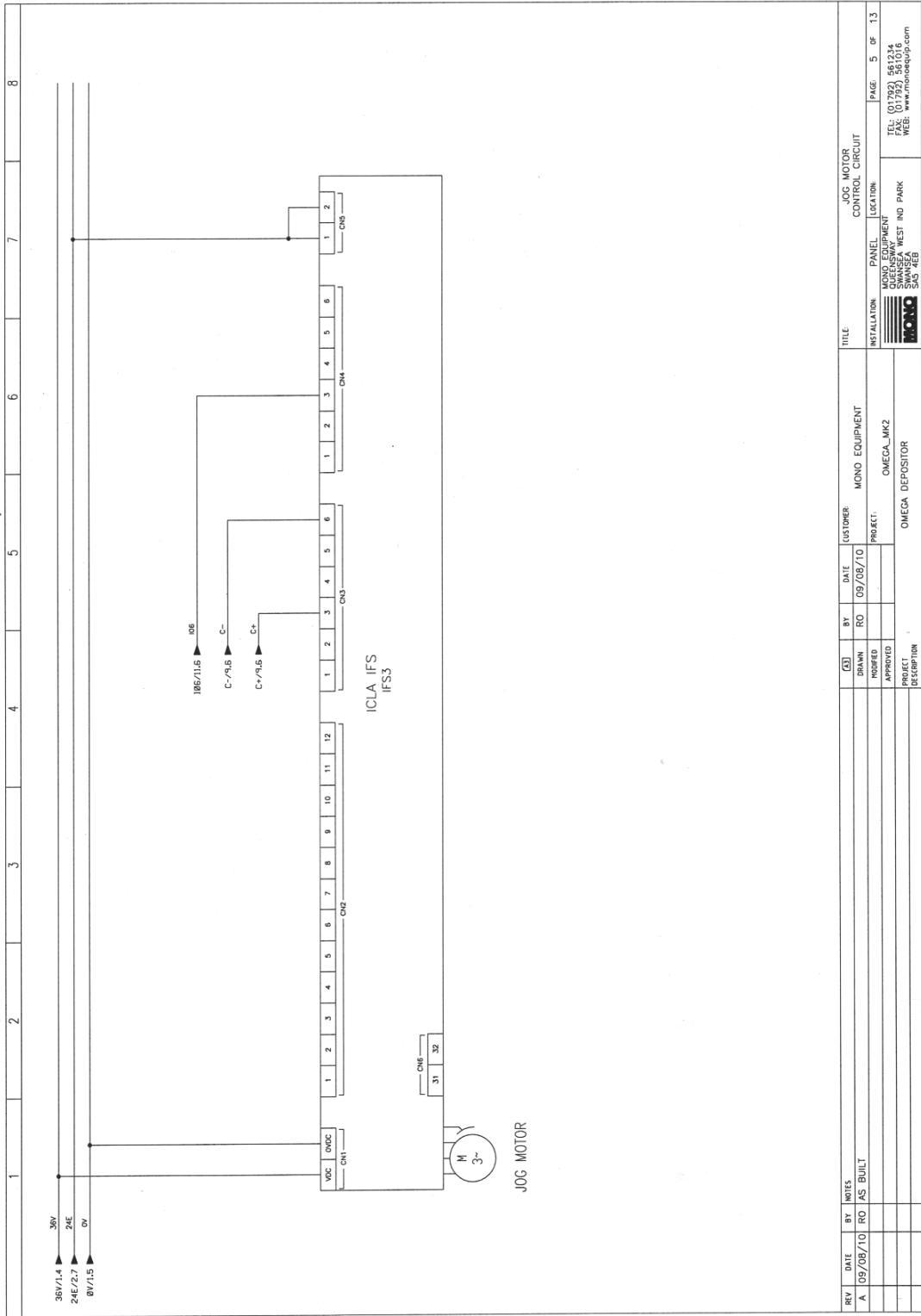

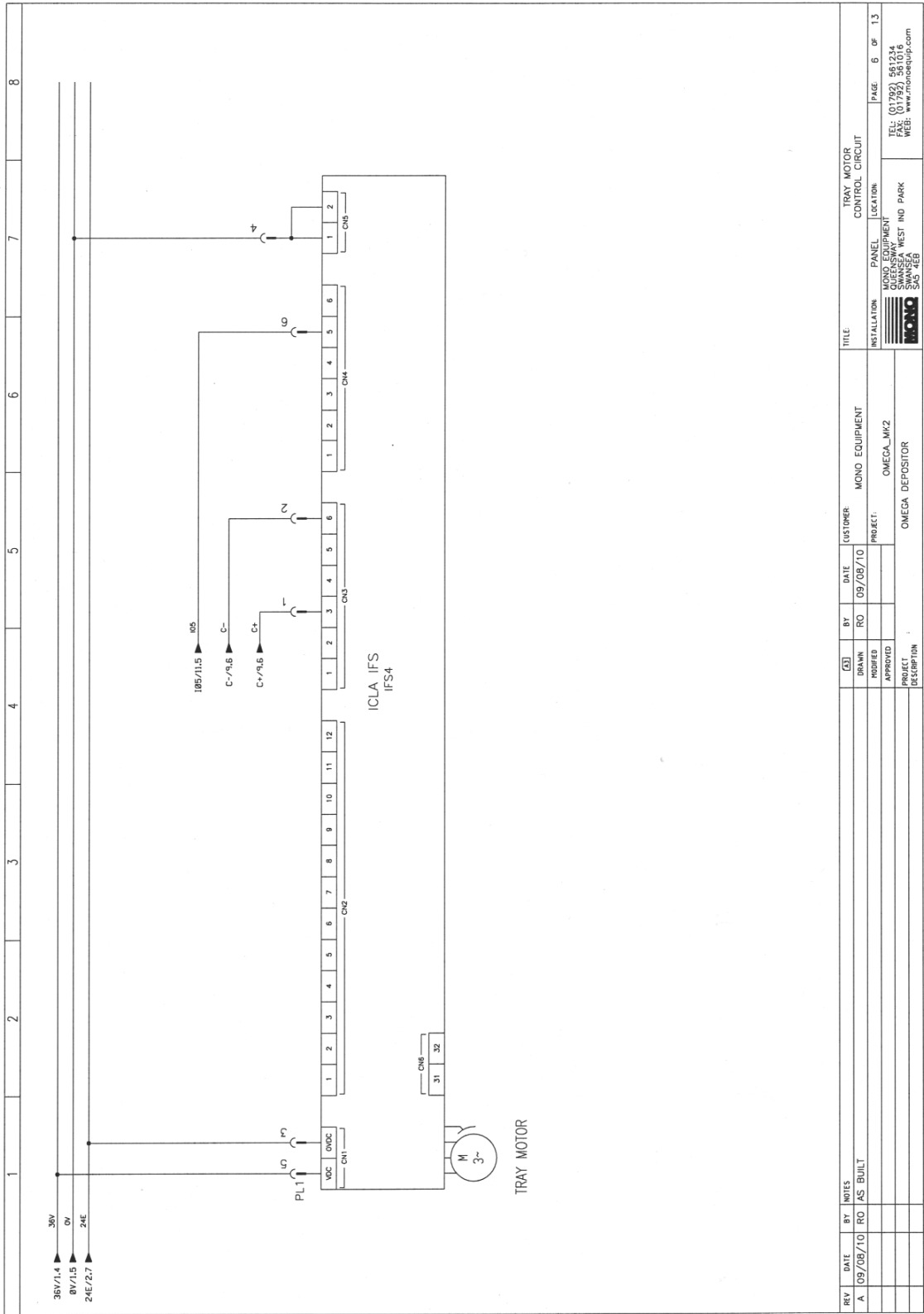

REV	DATE	BY	NOTES	DATE	BY	DESCRIPTION
A	09/08/10	AS	BUILT	09/08/10	RO	

TITLE		TRAY MOTOR CONTROL CIRCUIT	
INSTALLATION	PANEL LOCATION	MONO EQUIPMENT	OMEGA_WM2
MONO EQUIPMENT	SWANSEA WEST IND PARK	OMEGA DEPOSITOR	
TEL: (01792) 561234	FAX: (01792) 561016		
WEB: www.monoequip.com			

REV	DATE	BY	NOTES
A	09/08/10	AS	BUILT

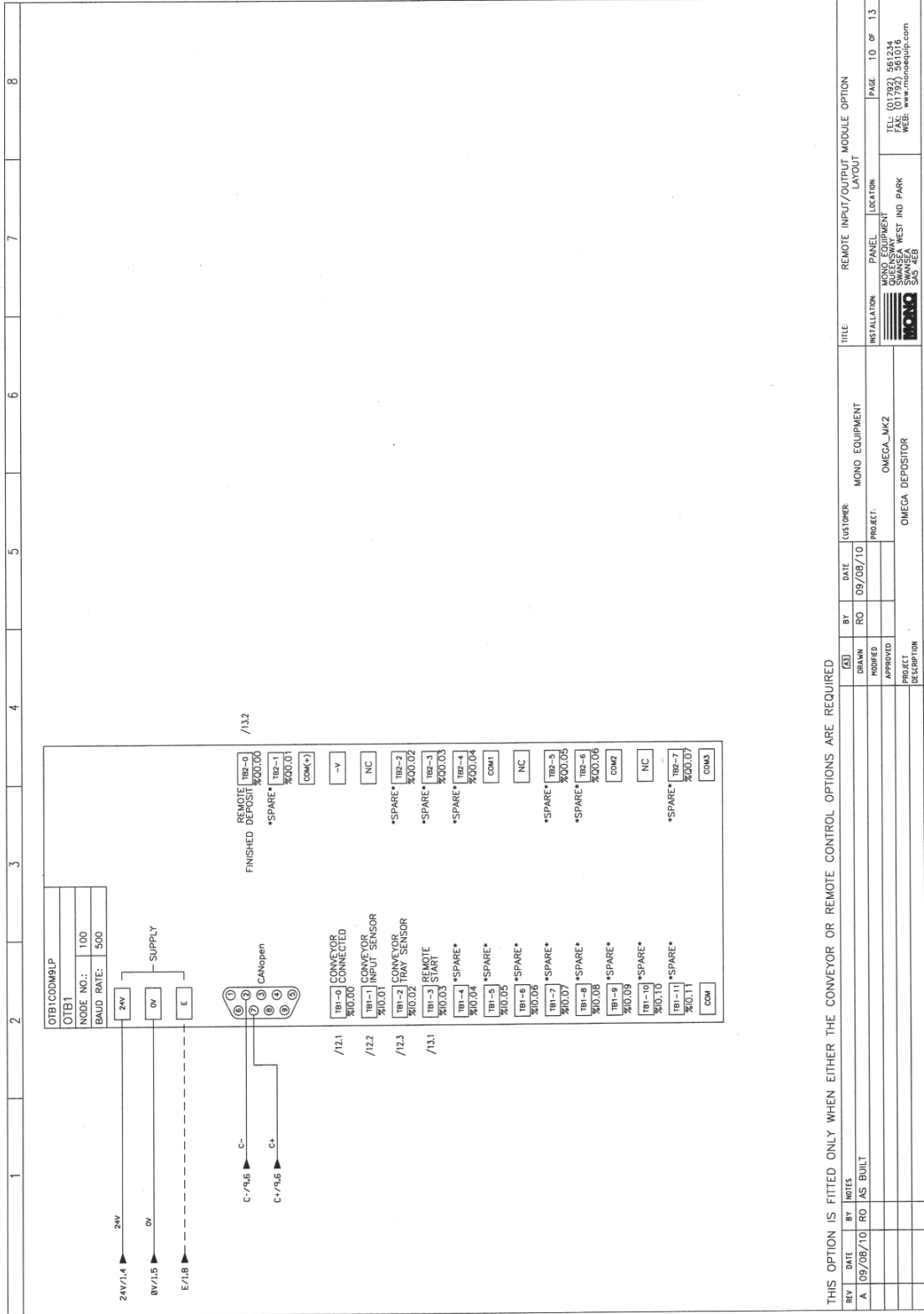

THIS OPTION IS FITTED ONLY WHEN EITHER THE CONVEYOR OR REMOTE CONTROL OPTIONS ARE REQUIRED

DATE	BY	DATE	BY	DATE	BY	DATE	BY	DATE	BY
09/08/10	RO	09/08/10	RO	09/08/10	RO	09/08/10	RO	09/08/10	RO

TITLE	INSTALLATION	PANEL	EQUIPMENT	LOCATION
REMOTE INPUT/OUTPUT MODULE OPTION LAYOUT	MONO	MONO	MONO EQUIPMENT	QUEENSWAY WEST IND PARK SWANSEA

PROJECT	DESCRIPTION
OMEGA DEPOSITOR	

FILE	DATE	FILE	DATE
ELL (0179)	5/6/24	ELL (0179)	5/6/24
PLC	5/6/24	PLC	5/6/24
WEB	5/6/24	WEB	5/6/24

PAGE	OF
10	13

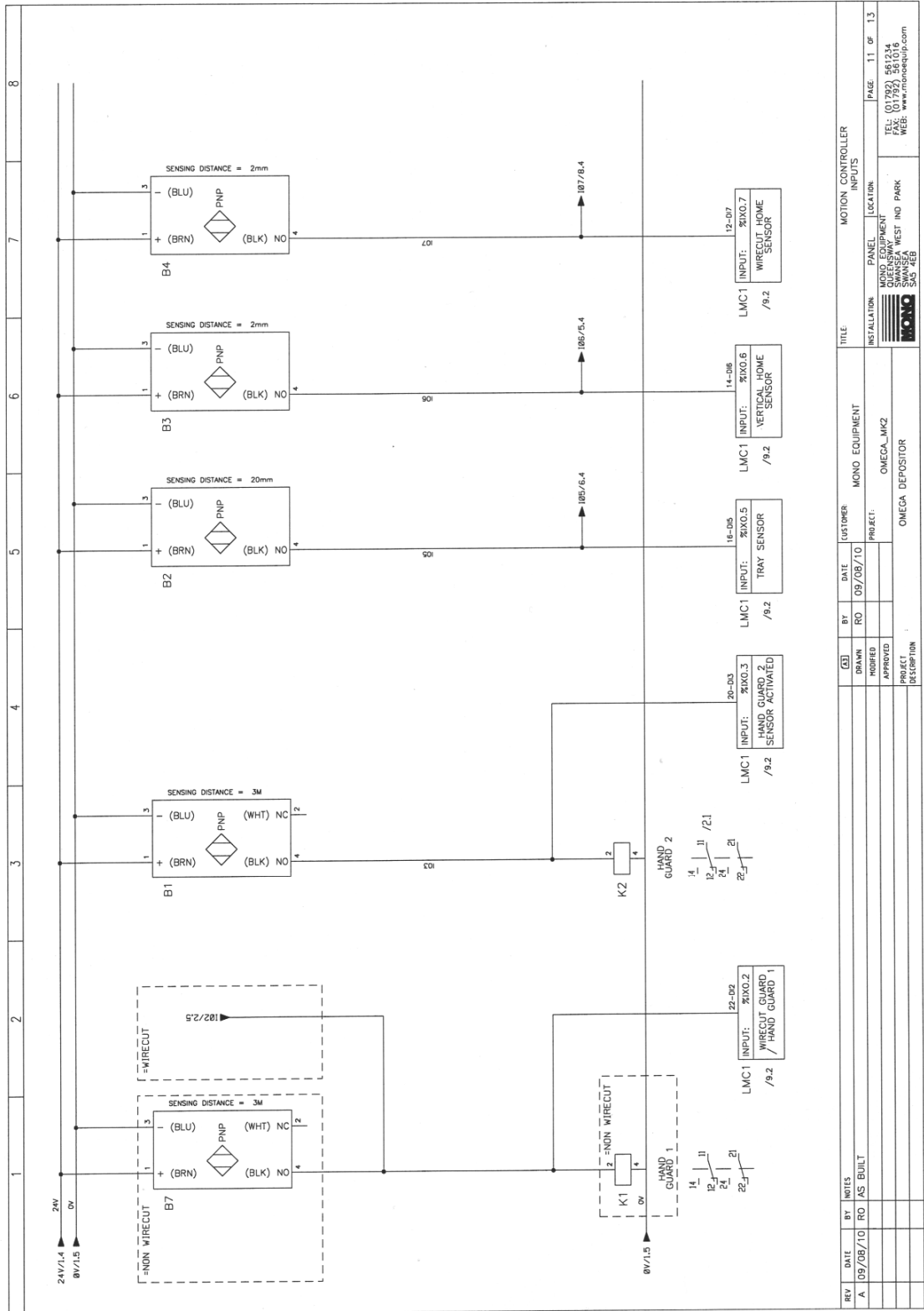

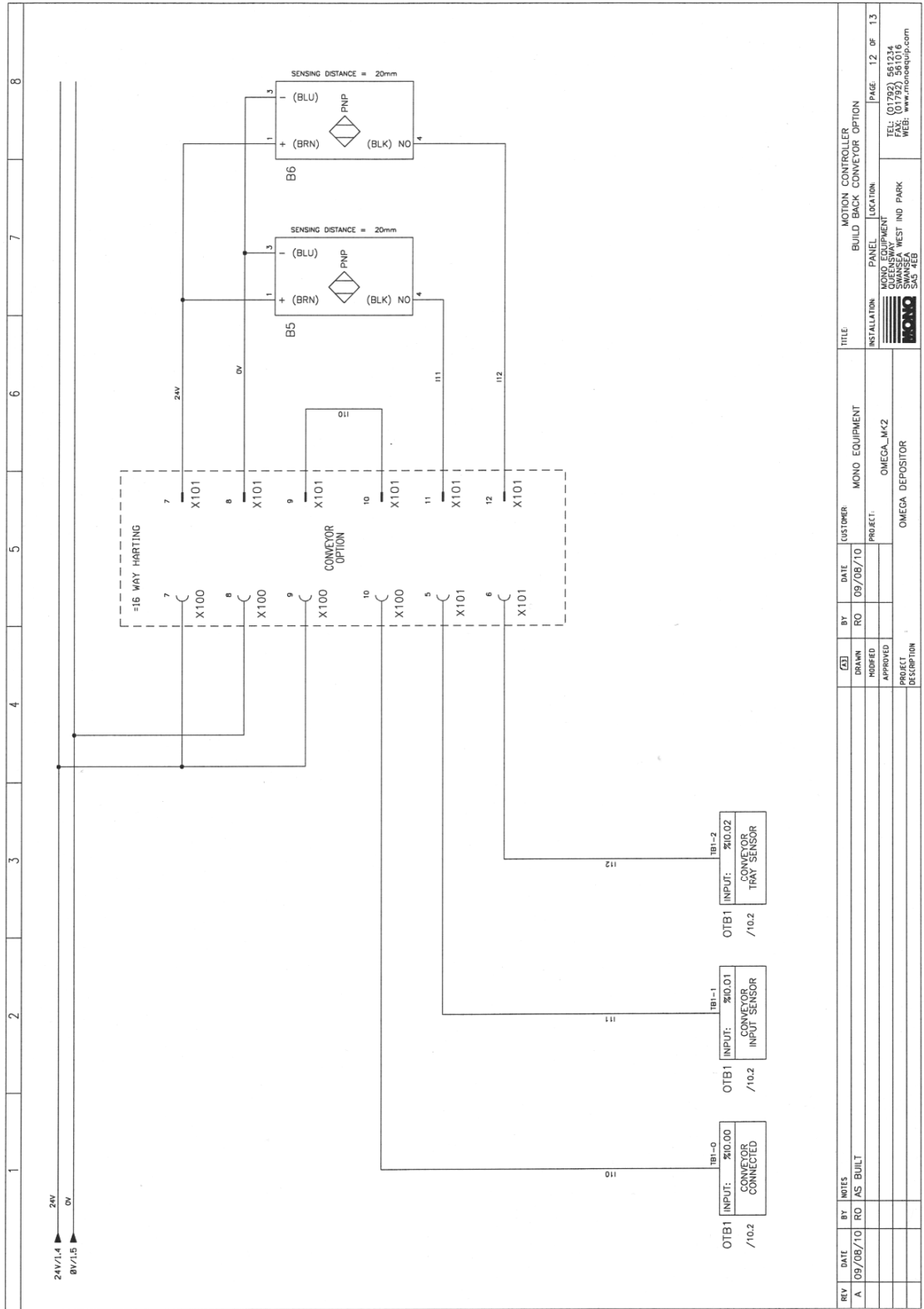

REV	DATE	BY	NOTES	DATE	BY	DATE	CUSTOMER	MONO EQUIPMENT	TITLE	PAGE	OF
A	09/08/10	RO	AS BUILT	09/08/10	RO	09/08/10	OMEGA DEPOSITOR	OMEGA_M<2	MOTION CONTROLLER BUILD BACK CONVEYOR OPTION	12	13
INSTALLATION PANEL LOCATION MONO EQUIPMENT SWINSEA WEST IND PARK SWINSEA SWS										TEL: (01792) 561234 FAX: (01792) 561016 WEB: www.monoequip.com	
DRAWN: [Signature] MODIFIED: APPROVED: PROJECT DESCRIPTION:											

The equipment mentioned in this manual has CE accreditation.

As it is our policy to improve our machines continuously, we reserve the right to change specifications without prior notice



Queensway,
Swansea West Industrial Estate,
Swansea.
SA5 4EB
UK

Tel. +44(0)1792 561234 : Fax. +44(0)1792 561016 : Spares +44(0)1792 564039

Email: marketing@monoequip.com

Web site: www.monoequip.com

▪ **DISPOSAL**

Care should be taken when the machine comes to the end of its working life. All parts should be disposed of in the appropriate place, either recycling or other means as the law permits at the time.