

MONO Modular Deck Oven with Integrated Prover

EN

Installation and Operation Manual



Product Version

- UK specification
- Eco-touch control
- Prover base unit

Enter Serial Nos. here.

Deck 1

Deck 2

Deck 3



In the event of an enquiry please quote these serial numbers.

Safety symbols

The following safety symbols are used throughout this document and manual (available at www.monoequip.com). Before using your new equipment, read the instruction manual carefully and pay special attention to information marked with the following symbols



WARNING

Indicates a hazardous situation that, if not avoided, could result in death or severe injury.



WARNING

Indicates a hazardous situation that, if not avoided, could result in death or severe injury.



CAUTION

Indicates a hazardous situation that, if not avoided, could result in minor or moderate injury.



Electrical safety and advice regarding supplementary electrical protection

Commercial bakeries, kitchens and food service areas are environments where electrical appliances may be located close to liquids, or operate in and around damp conditions, or where restricted movement for installation and service is evident.

The installation and periodic inspection of the appliance should only be undertaken by a qualified, skilled and competent electrician, and connected to the correct supply suitable for the load as stipulated by the appliance data label.

The electrical installation and connections should meet the necessary requirements of the local electrical wiring regulations and any electrical safety guidelines.

We Recommend:

- Supplementary electrical protection with the use of a residual current device (RCD)
- Fixed wiring appliances incorporate a locally situated switch disconnecter to connect to, which is easily accessible for switching off and safe isolation purposes. The switch disconnecter must meet the specification requirements of IEC 60947.

Your attention is drawn to:

BS 7671:2018 – Guidance Note 8 – 8.13 : Other locations of increased risk

It is recognised that there may be locations of increased risk of electrical shock other than those specifically addressed in Part 7 of BS 7671. Examples of such locations could include laundries where there are washing and drying machines in close proximity, and water is present, and commercial kitchens with stainless steel units, where once again, water is present. Where, because of the perception of additional risks being likely, the installation designer decides that an installation or location warrants further protective measures, the options available includes:

- Automatic Disconnection of Supply (ADS) by means of a residual current device having a residual operating current not exceeding 30 mA;
- Supplementary protective equipotential bonding; and
- Reduction of maximum fault clearance time.

The provision of RCDs and supplementary bonding must be specified by the host organisation's appointed installation designer or electrical contractor and installed by a suitably qualified and competent electrician so as to comply with Regulations 419.2 and 544.2.



The supply to this machine must be protected by a **30mA Type A RCD**.

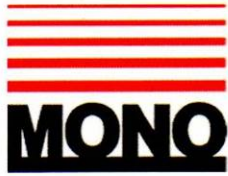

DECLARATION OF CONFORMITY

We hereby declare that this machine complies with the essential health and safety requirements of :-

- The Machinery Directive 2006 / 42 / EC
- The Low voltage Directive 2014 / 35/ EC
- The requirements of the Electromagnetic Compatibility Directive 2004 / 108EC, 91 / 263 / EEC, 92 / 31 / EEC
 Incorporating standards
 EN55014-1:2006+A1:2009+A2:2011
 EN55014-2:1997+A1:2001+A2:2008
- The General Safety of Machinery and food processing Standards applicable
- Materials and Articles intended to come into contact with food Regulation (EC) No. 1935 / 2004

Signed	
G.A.Williams – Quality Manager	

Date	
-------------	--

Machine FG Code.		Machine Serial No.	
-------------------------	--	---------------------------	--

A technical construction file for this machine is retained at the following address:

MONO EQUIPMENT
 Queensway,
 Swansea West Industrial Park,
 Swansea
 SA5 4EB
 UK

MONO EQUIPMENT is a business name of **AFE GROUP Ltd**
 Registered in England No.3872673 VAT registration No.923428136

Registered office: Unit 9, Bryggen Road,
 North Lynn Industrial Estate,
 Kings Lynn,
 Norfolk,
 PE30 2HZ



Important safety matters: fix a water leak immediately to help prevent electrocution

It is essential to regularly check for any signs of a water leak from an oven installation. If there is evidence of a water leak, do not ignore it. Immediately report it to a manager or as applicable to your organisation.

Furthermore:

- Isolate the oven from the electrical supply (see **Chapter 6**).
- Place an out-of-service notice on the oven.
- Contact MONO Equipment for assistance (see **Back Page**).

Ovens need to be maintained and serviced at appropriate intervals to help prevent water leaks from the internal plumbing and external hose connections. See **Chapter 16** for maintenance information.

Important notes



WARNING

- An electrical socket must be protected by a 30mA Type A Residual Current Device (RCD) before installation and commissioning of the oven.
- To reduce the risk of fire or electric shock, do not remove covers (or back sheeting). There are no user-serviceable parts inside. Repairs should be done by authorised personnel only.
- Never use the USB port to power or recharge electronic devices e.g., mobile phones. Incorrect usage causes damage to the oven and could result in a fire.



WARNING

- Be aware of hot surfaces.
 - Do not touch the front with bare skin.
- Failure to adhere to the cleaning and maintenance instructions detailed in this manual could affect the warranty of this machine.
- The oven should only be used for baking bread, pastries, and cakes.
- Some sections of this manual are for engineers only and the customer should not attempt to make any alterations.

Contents

	Page
1. Introduction	8
2. Overall Dimensions	9
3. Specifications	10
Electrical specifications	11
Environmental specifications	11
Mechanical specifications	11
4. Safety	12
5. Installation	12
General	12
Electrical connections	12
Important operation	12
Water supply requirements	13
Oven water system setup procedure	14
Exhaust Connections (if canopy fitted)	15
6. Isolation.....	17
7. Cleaning	18
Daily cleaning instructions.....	18
Weekly cleaning instructions.....	18
8. Operating Conditions.....	19
9. Principle of Oven Operation	19
Baking heat	19
Steaming function	19
Baking advice	19
10. Touch Screen Operation.....	21
Basic operation.....	22
Baking using the “Favourites” menu	23
Baking using the “Manual Bake” menu	26
Baking using the “Programmes” menu	29
Creating a program	32
7-Day timer	38
Settings	39
11. Using the USB port	45
12. Diagnostics	49
13. Passcodes.....	50
14. Troubleshooting	52

- 15. Service and Spares 53**
 - Oven spares 53
 - Service Information 55
- 16. Maintenance..... 56**
 - General maintenance 56
 - Light bulb replacement 56
- 17. Oven Electrics 58**
 - Electrical drawings..... 58
 - Electrical panel main components 67
- 18. Prover Operating Instructions..... 69**
 - Prover controls 69
- 19. Prover Electrics 70**
 - Electrical drawings..... 70

1. Introduction

The electric modular Deck Oven is an easy-to-use practical, good-looking oven, giving an excellent heat recovery rate and an even bake across a wide range of bread and confectionery products.

Good looking and completely reliable

Conceived with the no-nonsense requirements of both the independent and in-store baker in mind, designed to be visually pleasing and give reliable service for many years visually. This oven will more than satisfy the most discerning customer.

Top-quality specification

The external and internal contact surfaces are stainless steel.

Each modular deck has durable reinforced one-piece tiles and increased high-grade insulation and high-temperature ceramic sealant to make the oven more efficient.

The oven comes with a patented integral steaming system, which reduces energy consumption and the overall size of the oven. The system produces natural steam with the advantages of spray steam. Pre-steam is also available to reduce the effects of long loading times.

No drainage is required.

Eco-touch ovens are supplied with **TOUCH** displays for user-friendly control. This display can show pictures of product types or program numbers that have been set by the user. When not being used, the screen can show your company logo. A voice-prompt facility is also available for basic instructions like “Bake over”.



ECOTOUCH
SCREEN
CONTROLS



The lights are low voltage, sealed from the chamber and easily accessed from outside the oven.

Fitted with a choice of hinged easy to clean glazed doors (using low energy-loss reflective glass for high visibility) or metal doors, means low energy consumption and the high kW rating gives good recovery. (0-100% heating available both top and bottom).

As it is our policy to improve our machines continuously, we reserve the right to change specifications without prior notice.

2. Overall Dimensions

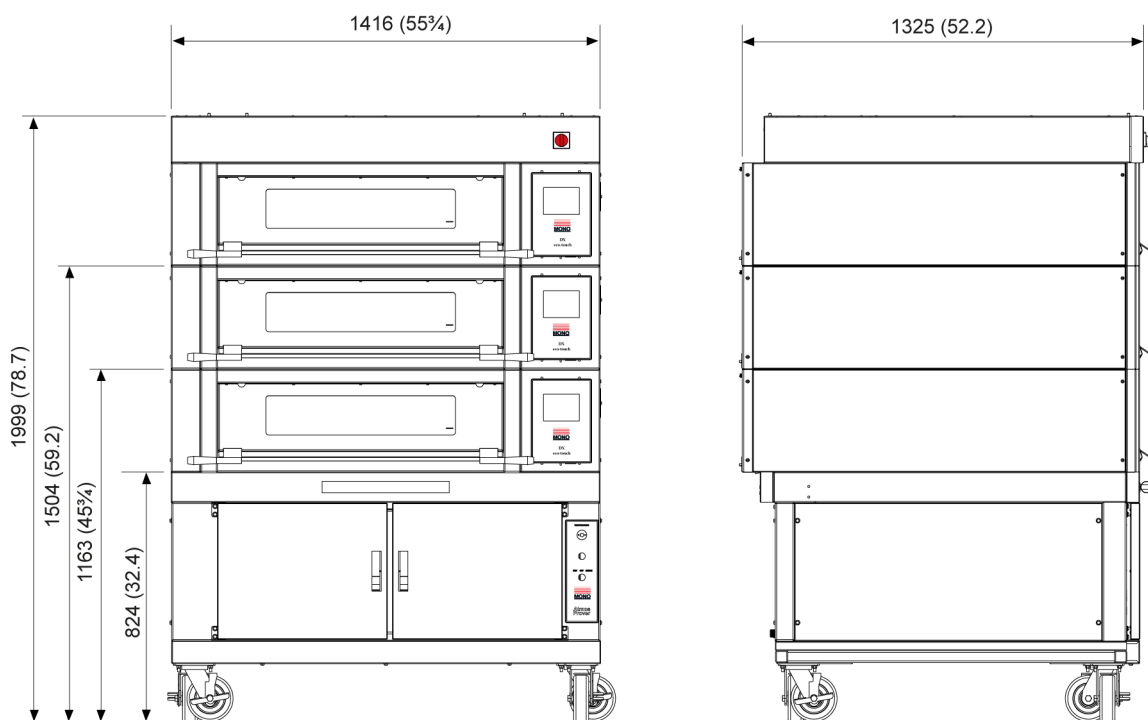

Note: All dimensions are in mm (inches) and are approximated.

Oven	2-trays wide
Width	1416 mm (55¾ inches)
Depth including handles	1325 mm (52.2 inches)
Height (to first deck)	824 mm (32.4 inches)

Prover	
Number of trays	8
Size of trays	600 mm x 400 mm

3. Specifications

Electrical specifications



Warning! ■ Separate electrical supplies to each deck and the prover base must have their own 30mA Type A Residual Current Device (RCD).

Table 1: Electrical loading per modular deck (2 trays wide)

Voltage	Power
400 Vac (50 Hz), 3-phase + neutral + earth	6 kW, 9 Amps

Table 2: Electrical loading for prover unit

Voltage	Power
230 Vac (50 Hz), 1-phase	1.8 kW, 8 Amps

Environmental specifications

The noise level is less than 80 dB.

Mechanical specifications

Table 3: Weights for standard-size deck oven

Specification	Nominal trays wide	Modular decks	Weight ⁽²⁾	
			Lbs	Kg
Total oven weight (including base prover)	2	3	(1)	(1)
Weight per oven chamber module	2	-	421	191.5
Weight per oven canopy module	2	-	31	14
Weight per fan module	2	-	62	28
Weight of product (maximum) per deck	2	-	86	39
Weight of prover	2	-	(1)	(1)

(1) To be advised. Contact MONO Equipment for information.

(2) All weights are approximate.

4. Safety

The Bakery Manager or Supervisor must carry out daily safety checks. Bakery staff **must not**, under any circumstances, remove panels to access any part of the oven.

Only fully-trained and authorised persons are permitted to do any work on the oven. Authorised electricians must carry out all repairs and maintenance of electrical units. Always disconnect or isolate the power supply before starting any maintenance (i.e. opening panels) or cleaning work on the oven.



Warning!

- Before using the oven, check that:
 - All cover panels and pipe fittings are secure.
 - The door handles are not damaged.
- If the oven is damaged or malfunctioning, stop using it.
 - Do not attempt any repairs.
 - Contact the Mono Service Department for advice.
 - Fit only **MONO** spare parts to this oven.
- All connections to the oven must comply with the statutory requirements of the country of installation.
- Never use the USB port to power or recharge electronic devices e.g., mobile phones. Incorrect usage causes damage to the oven and could result in a fire.
- Operate the oven only as described in this manual.



Warning!

- Separate electrical supplies to each deck and the prover base must have their own 30mA Type A Residual Current Device (RCD).
- Always fit a wall isolator to isolate the oven completely. The isolator must be visible, labelled, and easily accessible by an operator.
- Always check the electrical ratings on the nameplate before connecting power.



Caution!

- Be aware of hot surfaces:
 - Always use oven gloves when loading or unloading the oven.
 - Allow time for the oven to cool down before cleaning it. To prevent door glass from shattering, do not clean the oven glass when hot.
 - While the oven is in operation (and for some time after use), it is inadvisable to touch the oven window or the surrounds because of conducted heat.
- The oven owner is legally obliged to instruct staff on these safety points and the safe operation of the oven. Therefore, these instructions should not be removed from the working area.
- Do not store items on top of or behind the oven.
- Only use the oven for baking bread, pastries, and cakes. Contact Mono Equipment for other product-making machines.
- No unauthorised modifications to the oven are permitted. Only use MONO spare parts.

5. Installation

General

- A hard smooth level floor is recommended on which to position the oven and access for maintenance should be considered.

The oven is not designed to be "built in" so sufficient clearance must be left in front of the access panels (right hand side) to allow for servicing.

- If not chosen as an oven option, it is recommended that an extraction hood be placed above the oven to disperse excess steam and heat, which could have an adverse effect on the bakery ceiling and ambient temperature.
- A chain retainer should be fitted, that is shorter than the power cables, to protect them from strain if the oven is moved. (Fit to the wall or floor and the base, using hole provided in castor fixing corner plates).
- Installation must be made by a trained authorised engineer and all utilities must conform to all local regulations.

Electrical connections

- The main connection point for all deck supplies is at the top of the oven.
- A wall isolator must be available in order to completely isolate the oven. This isolator must be clearly accessible to the oven operator.
- Read the **Safety** section on **page 11**.
- Electrical loadings are in the **Specifications** section.

Important operation

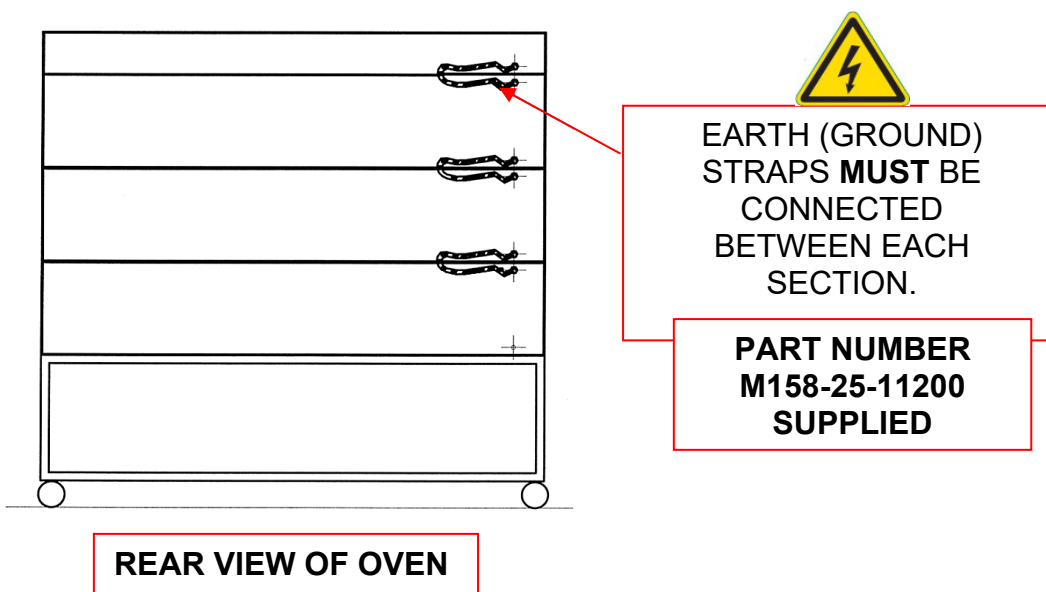

Water supply requirements

Note

The set up procedure on the next page must be followed to allow the steaming system to function correctly.

Oven

- All ovens with a steam function require a ¾" BSP hot or cold water supply at a pressure of 2 - 3 bar (29 – 44 psi). The water supply should comply with local water regulations.
- A manifold supplies all decks from one connection point.
- For proper operation of the steam system, it is recommended that the water supply also has the following specifications:

Hardness 0 – 4 grains per gallon

PH range 7.0 to 8.5

Chloride concentration 0 – 20 ppm

Consult Mono for proper water filtration system information.

- No drain is required for this oven.
- A non-return check-valve is supplied fitted to the water inlet manifold.

Prover

- The Prover requires a ¾" BSP cold water supply at a pressure of 2 - 3 bar (29 – 44 psi).
- Washing machine type hose

Oven water system setup procedure



It is imperative that the water delivery to the deck oven is checked for the steam system to operate correctly.

Note that dynamic pressure, not static pressure, is being measured.

Procedure

1. Flush out the main feed pipe to be used until water runs clear and free from debris.
2. Connect the main feed to the oven.
3. Connect flexible hoses to each deck.
4. Place a container under the test valve **(B)**.
5. Slowly open test valve **(B)** fully and, with the water flowing, set the regulator **(C)** to 0.75 bar using the screw underneath **(D)**.
 - Never use the oven above this setting.
6. When the pressure has stabilised, shut the test valve **(B)**.
7. Repeat steps 4 to 6 at the end of the installation.

Figure 1: Water regulator setup (located on rear of oven)

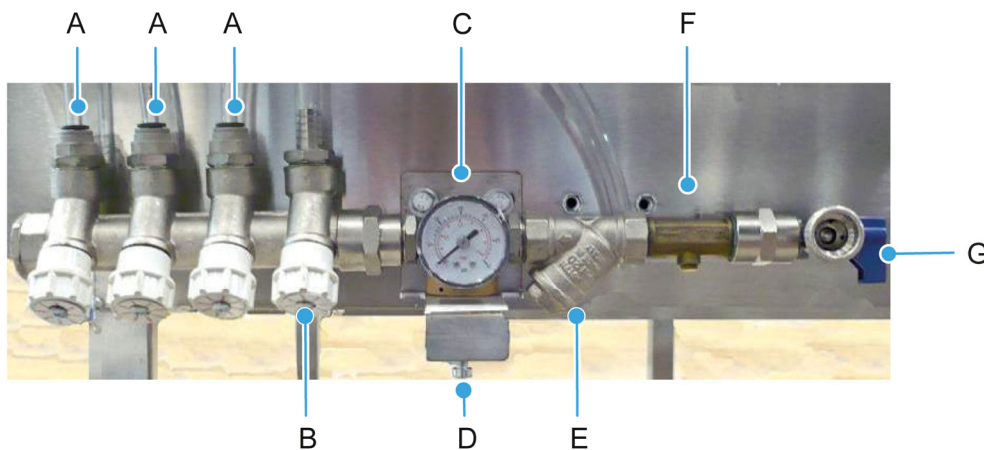

-
- A. To ovens
 - B. Test valve
 - C. Regulator
 - D. Adjusting screw to 0.75 bar
 - E. Filter
 - F. Dual check valve backflow prevention device
 - G. Stop tap
-

Exhaust Connections (if canopy fitted)

- Ideally, an exhaust duct should rise 2 metres above the bakery roof and be protected from wind and birds by a duct protector.
- It should be of a suitable material to take the high temperatures and humidity expected.
- It should be flexible and easily removable at the oven connection point.
This allows the oven to be moved for cleaning when required.

Figure 2: Canopy (without fan) dimensions

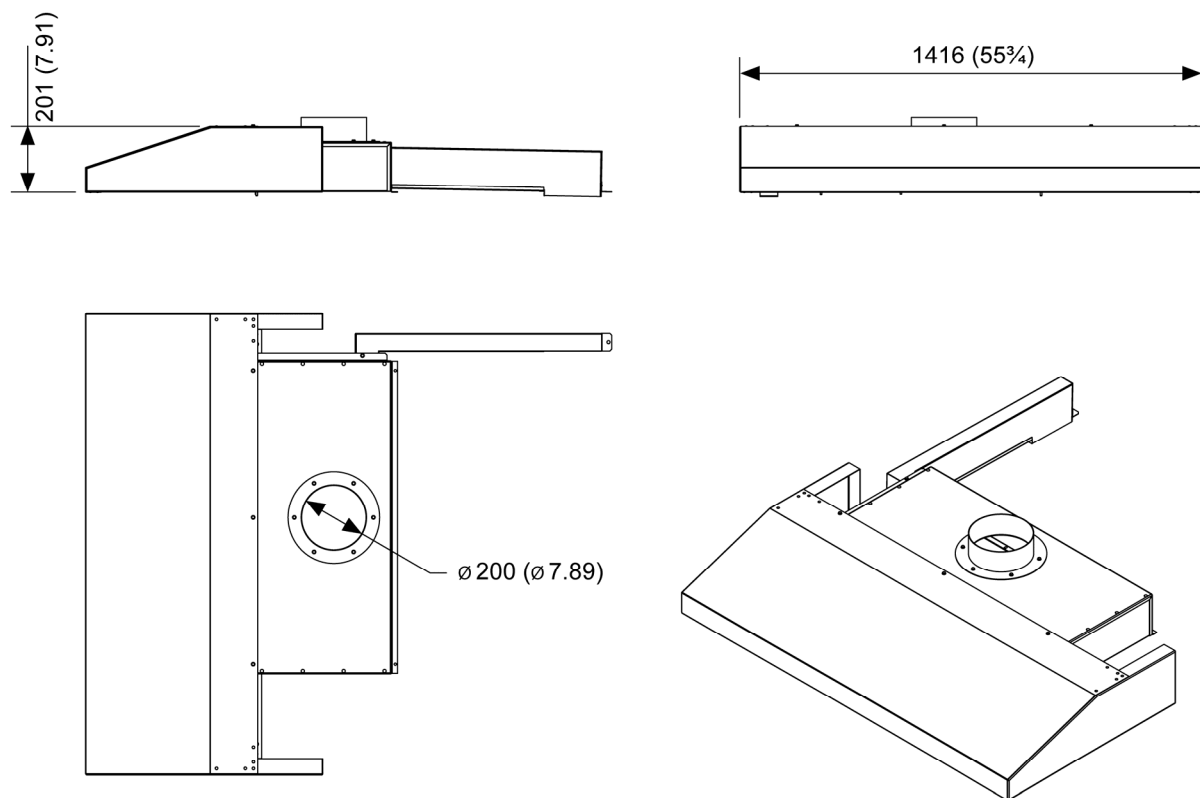

Dimensions are in mm (inches)

Figure 3: Canopy (with fan) dimensions

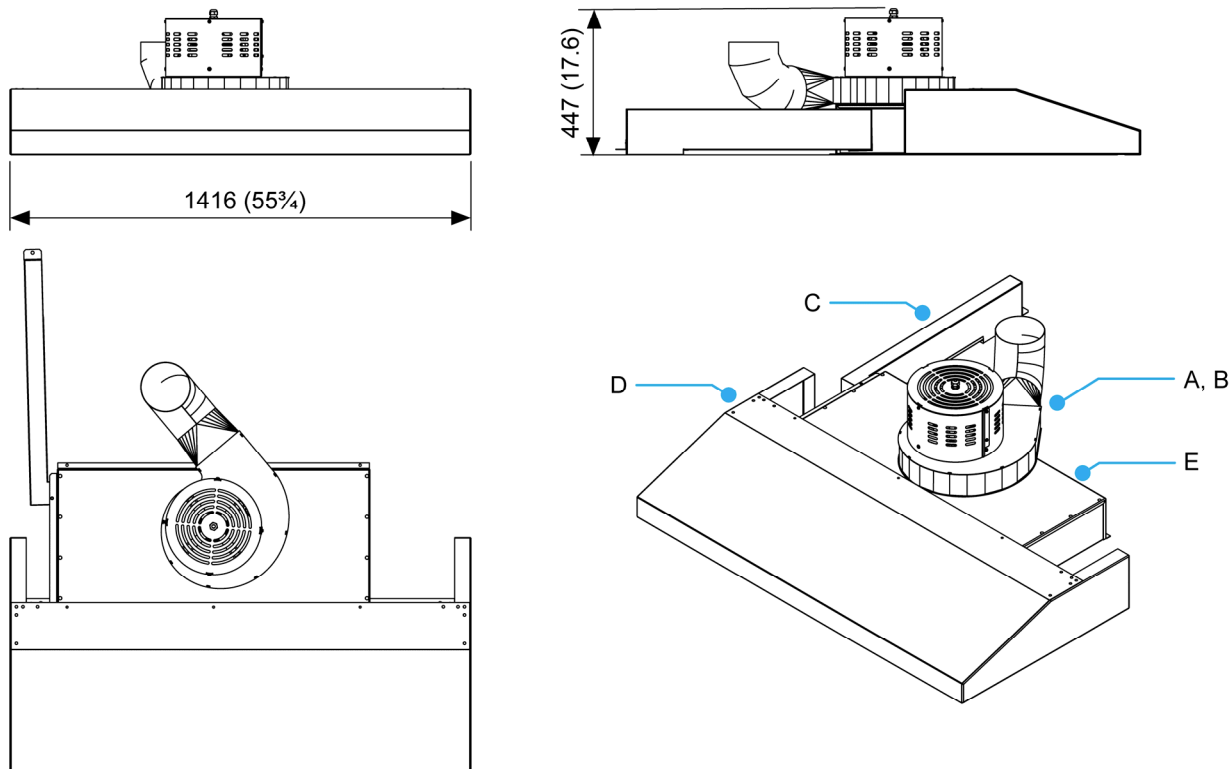

Dimensions are in mm (inches)

Table 4: Canopy parts

Item		Part number
A	Extraction fan assembly	247-08-04900
B	Inlet ring	247-08-05100
C	Flue assembly	257-10-00010
D	Canopy assembly	257-10-00016
E ⁽¹⁾	Extraction duct assembly for 2-tray oven width	257-10-00022

⁽¹⁾ Contact Mono Equipment for the availability of other extraction duct assemblies.

6. Isolation

A wall isolator, rated for the specific model of oven installed, must be available to isolate the oven completely in an emergency. The isolator must be clearly accessible and known to the oven operator.



Warning!

The “Power Off” button on the front of the oven does not isolate the power supply.

To stop the oven in an emergency,
switch off at the main isolator

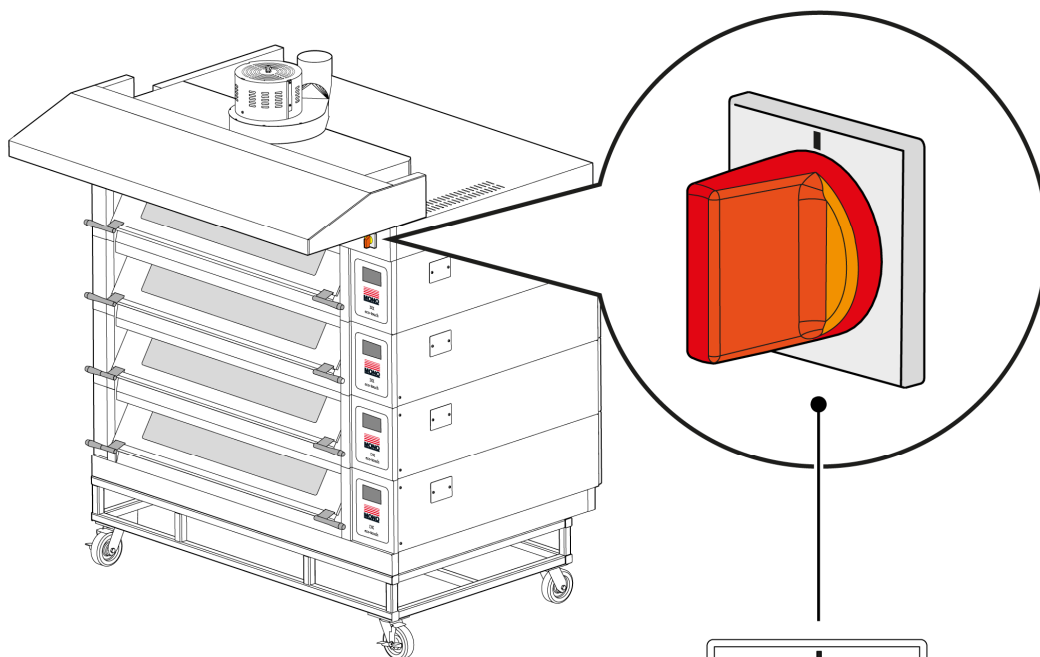

Main isolator switch = I (on)
(not isolated)

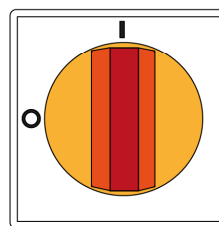

Main isolator switch = 0 (off)
(isolated)

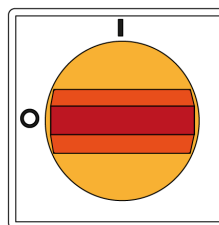

7. Cleaning

Daily cleaning instructions



Isolate the oven and prover from the mains supply before cleaning.



Take care water does not enter the control-panel mounting or roof-mounting fan.

Procedure

1. Sweep any debris out of the oven and prover **after** they have been allowed to cool.
Note: Use a vacuum cleaner with metal attachments (i.e. able to take the heat), if available.
2. Brush and scrape off any flour and dough adhering to the prover cabinet inner surfaces. Use only a stiff brush or plastic scraper.
3. Brush down and wipe oven front, back and sides with a damp cloth.
4. Spot clean outside with a damp cloth, which has been soaked in a solution of mild detergent, and hot water, paying particular attention **to ensure excess water is not applied around the area of the electrical panels and switches.**

Weekly cleaning instructions



Isolate the oven and prover from the mains supply before cleaning.



Take care water does not enter the control-panel mounting or roof-mounting fan.



Do not stand on the roof.

Procedure

1. Complete the daily cleaning procedure, as above.
2. Use a nylon brush to scrub the wheels with a mild detergent and hot water.
Note: Using too much water eventually rusts the metalwork.
3. Ensure the oven roof area is clear of debris and dust build-up.

8. Operating Conditions

- Leave a clear space of at least 2 metres (6 ft.) in front of the oven for ease of operation and safety reasons.
- Do not use bakery utensils to operate the control panel buttons.

9. Principal of Oven Operation

Note

Operators should refer to their own company's recipe manual for the oven temperature settings.

Baking heat

Products bake in an insulated, heated chamber with the temperature regulated by a thermocouple. A digital temperature read-out is visible on the control panel screen. Baking heat is radiant, with top and bottom heat adjustable by separate controls. This technology enables heat to be “balanced” according to product requirements.

Steaming function

Steam is provided from an integral steam unit and injected into the chamber on demand. Programmed parameters automatically control this function.

After being steamed, the oven does not allow more steaming until the steam unit has recovered heat, typically for 3 to 10 minutes, depending on the selected program.

All deck ovens have a steam damper that evacuates steam humidity into a vent at the rear of the oven.

Baking advice

Advice for getting the best results from deck ovens:

Loading

1. **Do not place the products too close together.** *If the loaves are close to each other after the oven spring (expansion), it results in soft sides and may collapse on cooling.*
2. **Place the product evenly within the oven.** *Products bunched together are paler than those widely spaced.*
3. **Products should not be too close to the edge of the tile.** *As it expands towards the front, one side of the loaf may enter the cooler air by the door.*
4. **Door-opening should be kept to a minimum** *because cold air enters the oven. Cooling of the sidewalls and roof causes the finished product to be lighter locally at the front and wastes heat. If loading times are consistently long, alter the front-top heat to put more heat at the front.*
5. **The product can form a skin if the loading takes a long time,** *which causes an imbalance and a less attractive finish. By using the pre-steam function before loading, this can be minimised. The steam function turns the elements off and injects steam to increase the humidity.*

Bake settings

1. A good starting point for baking bread in Mono deck ovens is **225 °C (437 °F)**.
Top heat: 60 to 65 **Bottom heat:** 40
2. For cookies (and similar products), the oven's heat can be turned almost off. However, it may still be necessary to place the trays with, e.g. cookies, onto upturned trays on the oven sole.
3. **Steam** should be kept to a minimum for energy efficiency, depending on the product and finish. **Times of between 9 and 12 seconds should be adequate.** It is a good idea not to focus on the temperature recovery – this can vary from oven to oven.

Is the product baked in the time and to the quality you require?

Below are some tips for modifying the bake to get the product that you require.

- If your product is **light on top**, decrease the bottom heat and extend bake time or increase the top heat.
- If the product **sides are pale** and the **top dark**, space the products well apart, drop the top heat, and extend the bake time.
- **If the bake time is too long**, first increase the top heat to speed recovery. If this does not give sufficient savings, increase the baking temperature.
- **To thicken the crust**, set the damper to be open for longer. Different ovens require different lengths of time.

10. Touchscreen Operation

Each deck has an independent, colour touchscreen for operating the oven.

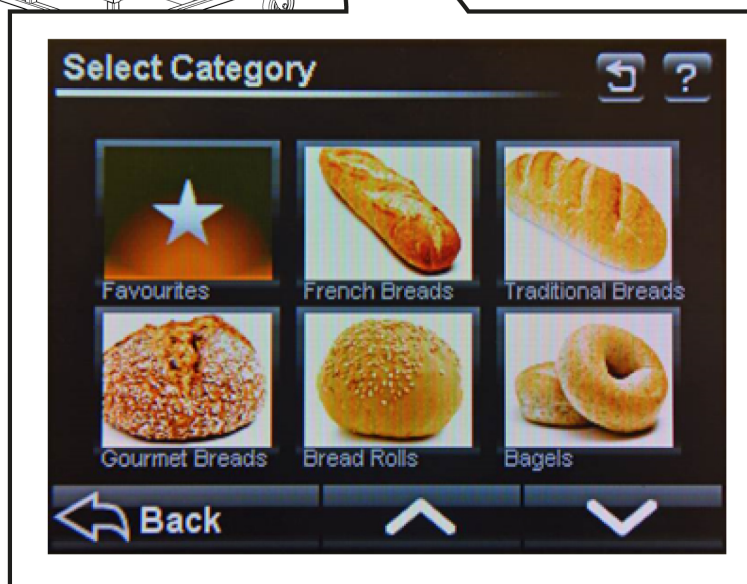
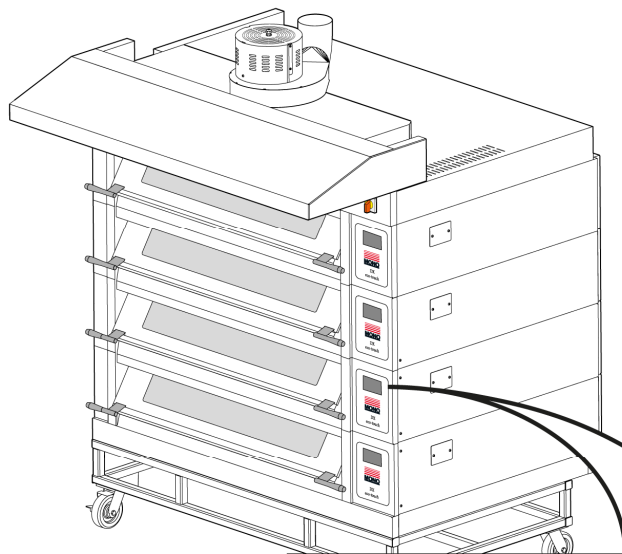

Basic operation

Operations are performed by touching an area of the screen, bringing up the next information panel or activating a function.



Do not use excessive force.
The pressure required to operate the panel is adjustable in the **Settings**.

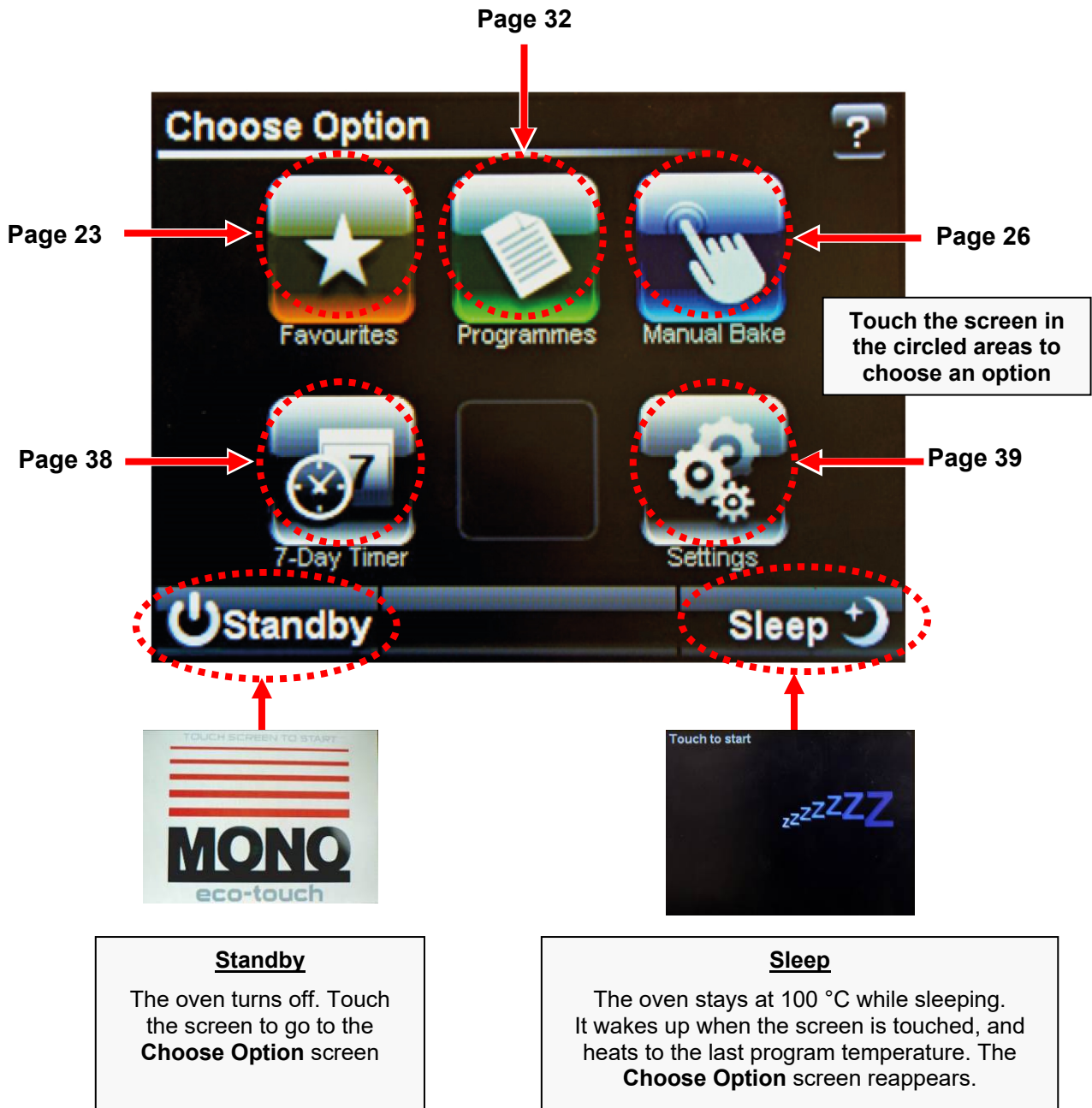

Baking using the “Favourites” menu

Touch to open the **Favourites** selection screen

1



OPTION SCREEN

Touch the name of the product required

2



Up to 5 products are listed on a page. Touch the **UP-ARROW** or **DOWN-ARROW** to see other pages of products

SELECTION SCREEN

Touch **Full Load** or **Half Load** to select a quantity
(This screen only appears if a half load is saved in the program)

3

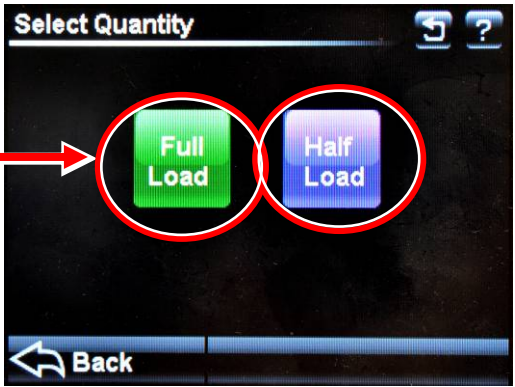

LOAD SCREEN

Touch the **Back** button to return to a previous screen

4

Wait for the oven to reach the required temperature (200 °C in this example)
 (The **Heating** message remains on the screen while the oven is heating up)

If the oven is too hot for the temperature chosen, the screen tells you to open the door for cooling. **Take care to avoid burns.**

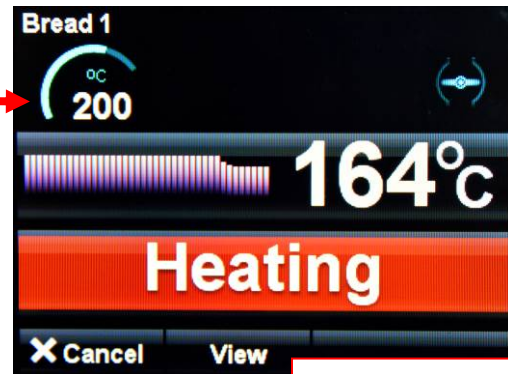

HEATING SCREEN

5

When the oven is at the correct temperature, the message changes to **Ready**. Now:

5.1. Open the door and carefully load the oven with the prepared trays of product.
5.2. Fully close the door.
5.3. Touch the **Start** button.

Tip! To help keep the oven hot, avoid opening the door more than needed.



READY SCREEN

6

The **Bake In Progress** screen shows the baking time remaining

Required temperature →

Temperature profile bar →

Bake time progress bar →

Actual oven temperature
 (This will rise and fall near to the required temperature)



Baking time remaining

Note: The actual temperature shown will rise and fall above and below the required temperature as the oven cools and reheats. **This is not a fault.**

7

At the end of the bake time, a sounder will be heard and **Bake Over** will flash. Now:

7.1. Touch the **Stop** button.

7.2. Open the door.

7.3. Carefully remove the trays of product.

Note! To keep the oven baking for extra minutes, touch the **+ 2 mins** button. This time can be adjusted in the set up.



Touching the View button during a bake (optional)

Touch the **View** button during a bake to show the settings for that particular bake.

Touch the **Cancel** button to go back to the previous screen. (It does not cancel the bake).



VIEW SCREEN

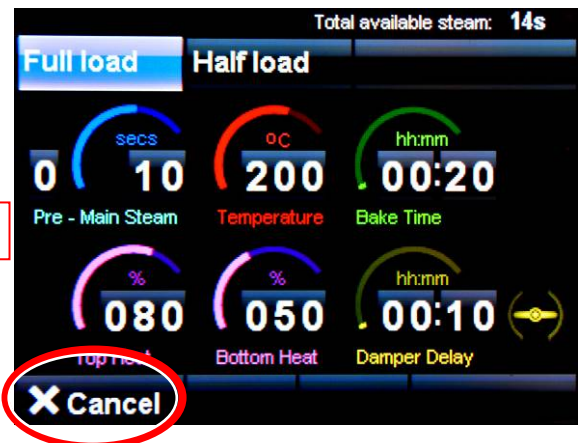

Baking using the “Manual Bake” menu

1
Touch to open the **Manual Bake** screen



OPTION SCREEN

2
Set the top and bottom heat
2.1. Touch a % button on the screen to activate the keyboard screen.
2.2. Key in the required percentage of heat.
2.3. Touch **OK**.



MANUAL BAKE SCREEN

3
Set the bake temperature
3.1. Touch the temperature to activate the keyboard screen.
3.2. Key in the required temperature.
3.4. Touch **OK**.



4
Set the bake time (optional)
4.1. Touch the time to activate the keyboard screen.
4.2. Key in the required time.
4.3. Touch **OK**.



Note: The bake time does not have to be set in manual mode. When **Start** is pressed, the timer increases instead of counting down. Touch **Stop** to finish the bake.

Set the Steam Time and Damper (if required)

(Manual Bake)

Steam

Touch and hold for the time (seconds) steam is required.

(This can be used before or during the bake)

Damper

Touch to set the Damper to open during the bake. (Icon changes colour to green)

Touch again to close the Damper. (Icon changes colour to red)



MANUAL BAKE SCREEN 2



Cancel

Touch at any time to return to the **Options** screen.

Touch **Start** to begin the bake.



Touch **Stop** when the end-of-bake buzzer sounds or when required time was entered.

Save (keep) the Manual Bake Program

(Manual Bake)



MANUAL BAKE SCREEN 3

Save settings

Touch **Save** to show an option screen.

(If no time was entered at the start of the bake, when **Stop** is touched at the start of the bake **Save** appears at the bottom of the screen)

9

10 Touch **Add to favourites** or **Save As...**

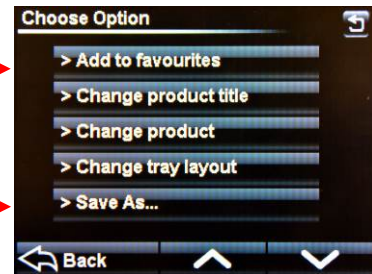

11 Use the keyboard to type the required name and touch **Save**.



Note: In manual mode, only one operation of the steam or damper is saved.

Baking using the “Programmes” menu

Note: This manual covers two versions of the firmware. (The oven is pre-set to show one only).

- **PICTORIAL** version shows choices of product categories
- **NUMERICAL** version shows ranges of program numbers

Touch to open the **Select Category** or **Program Choice** screen. **1**

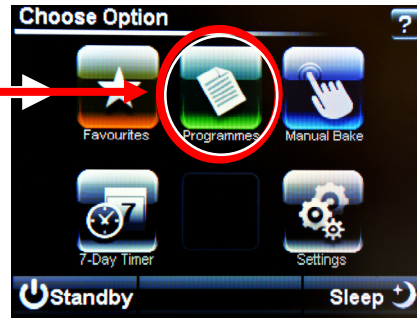

Touch the type of product or program-range. **2**

PICTORIAL or NUMERICAL

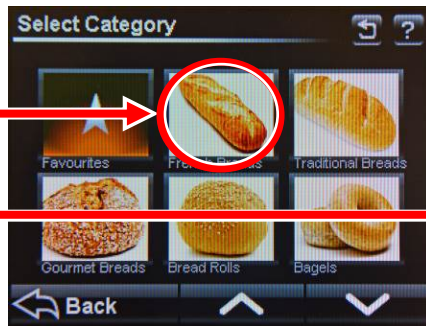

More choice screens

Touch the name or number of the product. **3**

OR

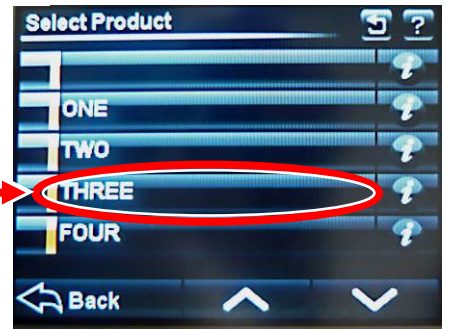
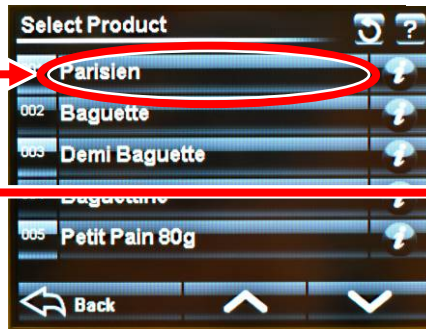

Touch **Full Load** or **Half Load** to select a quantity (This screen only appears if a half load is saved in the program). **4**

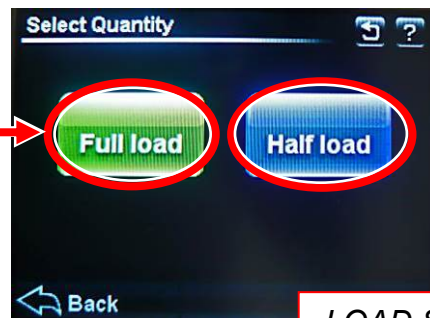

Touch the **Back** button to return to a previous screen.

LOAD SCREEN

5

Wait for the oven to reach the required temperature (200 °C in this example).
 (The **Heating** message remains on the screen while the oven is heating up).

If the oven is too hot for the temperature chosen, the screen tells you to open the door for cooling.
Take care to avoid burns.

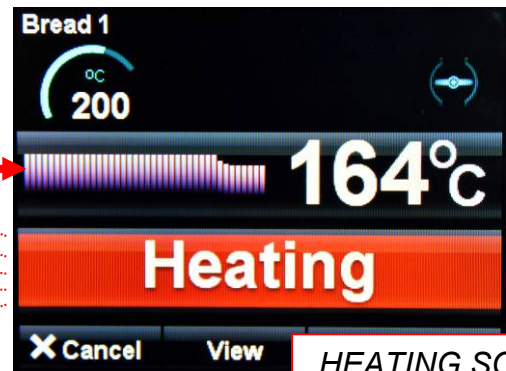

HEATING SCREEN

6

When the oven is at the correct temperature, the message changes to **Ready**. Now:

6.1. Open the door and carefully load the oven with the prepared trays of product.
6.2. Fully close the door.
6.3. Touch the **Start** button.

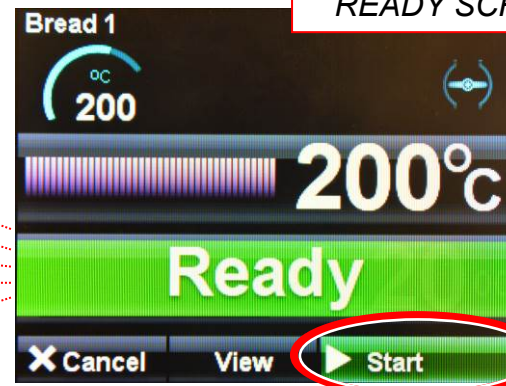

READY SCREEN

7

The **Bake In Progress** screen shows the baking time remaining.

Required temperature →

Temperature profile bar →

Bake time progress bar →

Actual oven temperature
 (This will rise and fall near to the required temperature)



Baking time remaining

Note: The actual temperature shown will rise and fall above and below the required temperature as the oven cools and reheats.
This is not a fault.

8

At the end of the bake time, a sounder will be heard and **Bake Over** will flash. Now:

8.1. Touch the **Stop** button.

8.2. Open the door.

8.3. Carefully remove the trays of product.

BAKE OVER SCREEN



Note: To keep the oven baking for extra minutes, touch the **+ 2 mins** button. This time can be adjusted in the set up.

Touching the View button during a bake (optional)

Touch the **View** button during a bake to show the settings for that particular bake.

Touch the **Cancel** button to go back to the previous screen. (It does not cancel the bake).



VIEW SCREEN

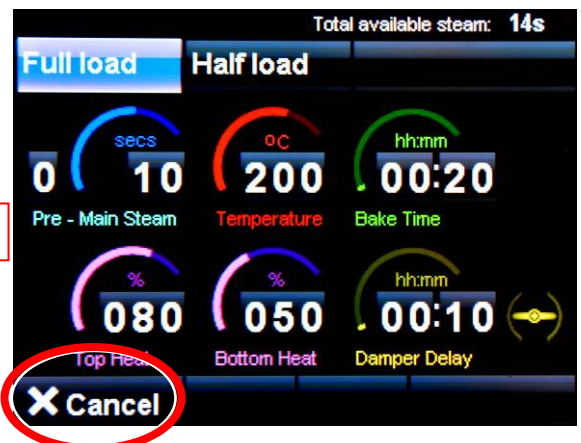

Creating a bake program

Touch **Programmes** to open the **Select Category** screen. **1**

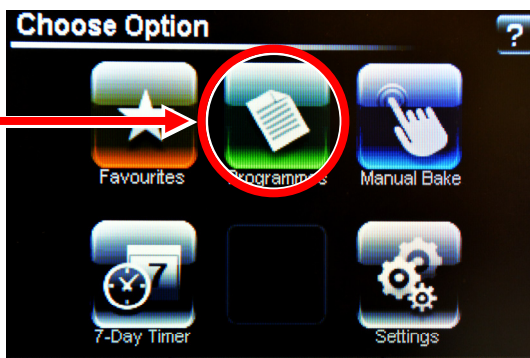

OPTION SCREEN

Touch the type of product wanted. **2**



CATEGORY SCREEN

Touch the "?" button next to the blank program to open the **Product Information** screen. **3**



SELECT SCREEN

Enter the Supervisor passcode

(Creating a Bake Program)

INFORMATION SCREEN



Touch **Option** to open the Pass Code screen. **4**

PASS CODE SCREEN

Enter the Supervisor pass code and then touch **OK**. **5**

Note: Default code = 123456. This can be changed in the Settings menu).



Enter the product bake details

(Creating a Bake Program)

OPTION SCREEN

Touch **Change product**. **6**

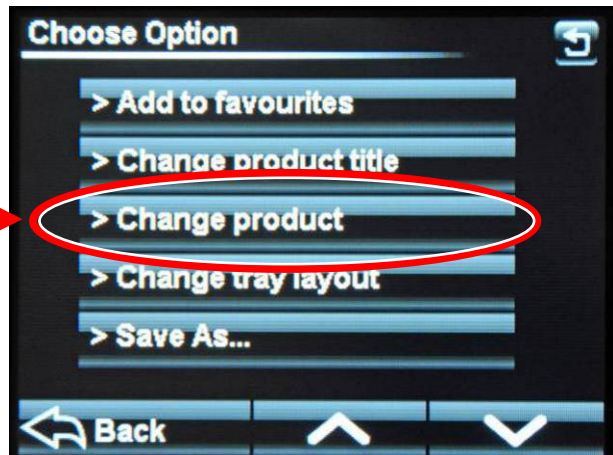

Load type

VALUE CHANGE SCREEN



Enter amount required and touch Done



Increase

Or use keypad

Decrease

Touch an item and then change the value by using the **UP-ARROW** and **DOWN-ARROW** keys, or the **keypad**.

Touch **Half load** to changeover to the half-load settings, if required.

To change back to the full-load settings, touch **Full load**.

Touch **Save** when satisfied with the settings.

7

Changing the tray layout

(Creating a Bake Program)

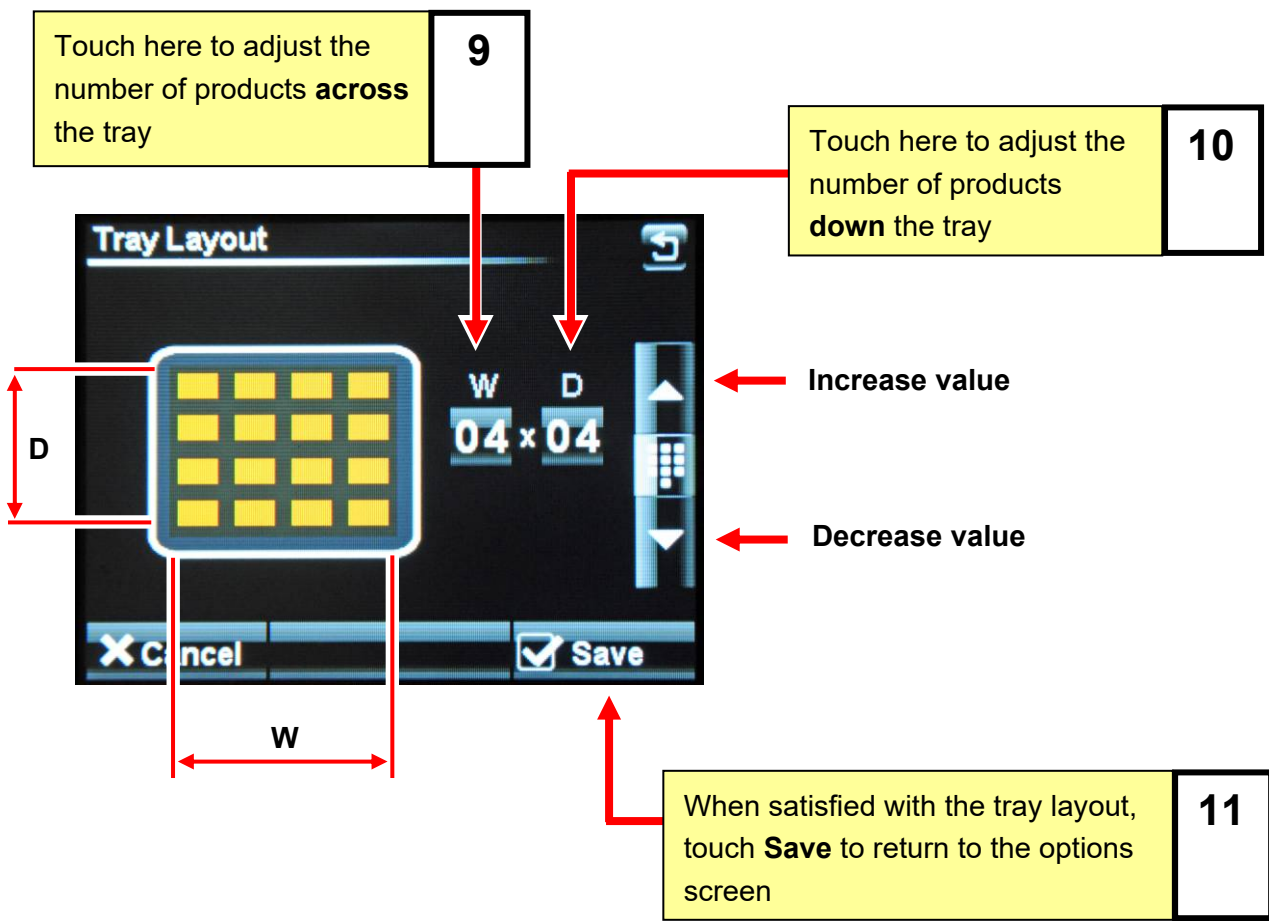
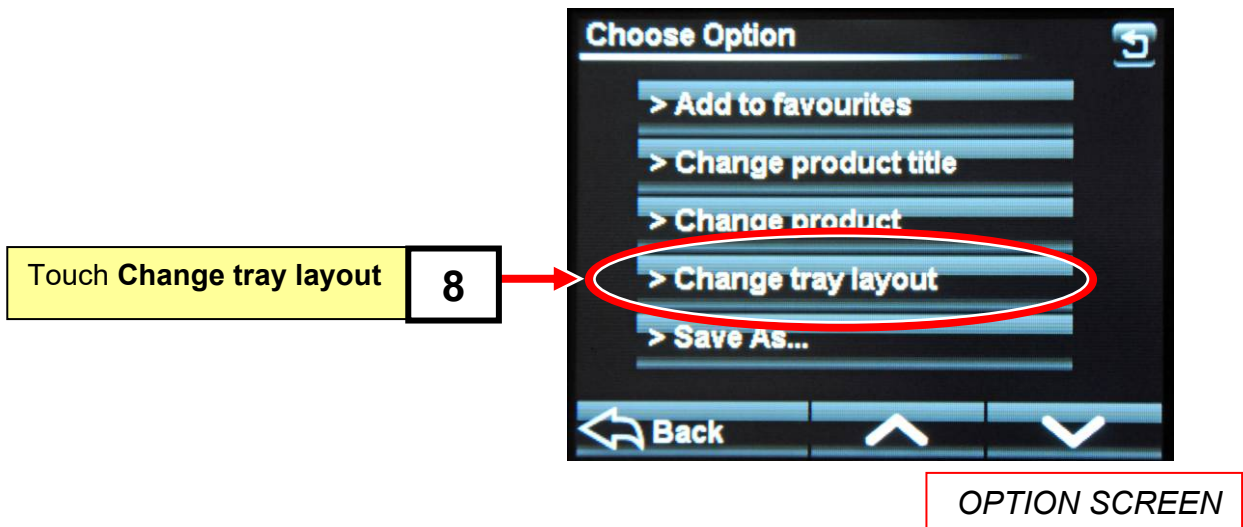

Save the product

(Creating a Bake Program)

OPTION SCREEN

Touch **Save As...** **12**

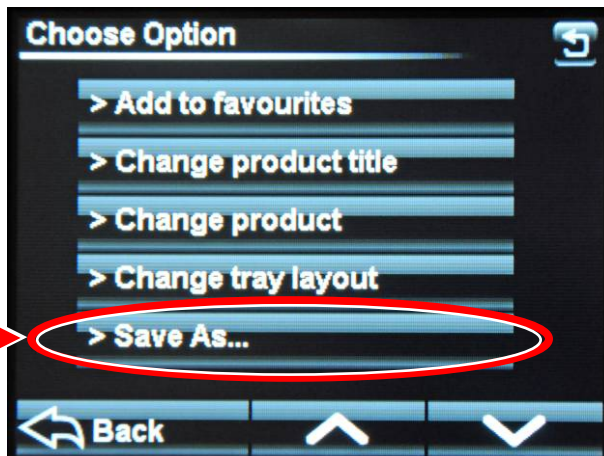

KEYBOARD SCREEN

Type in the new name and touch **Save**. **13**

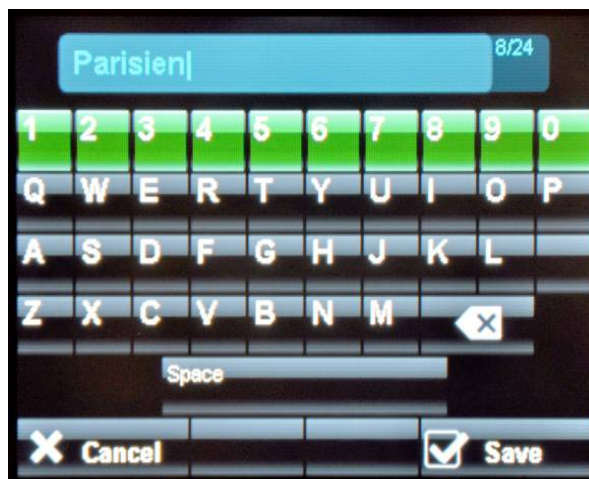

Add a product to the favourites list (optional)

Touch the type of product wanted to open the **Select Product** screen.

1



CATEGORY SCREEN

Touch the “i” (information) button next to the product you want as a favourite. (This opens the **Choose Option** screen)

2



SELECT SCREEN

Touch **Add to favourites**. (The product now appears on the favourites list).

3

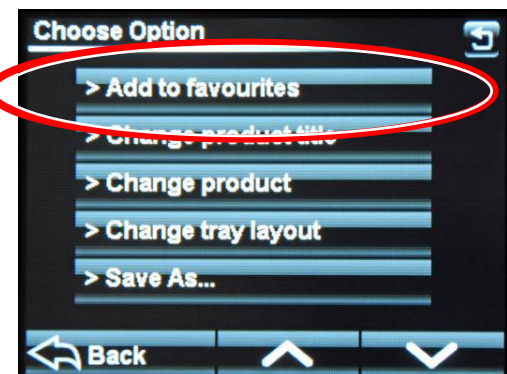

OPTION SCREEN

7-day timer

Touch **7-Day Timer** to open the setup screen.

1



OPTION SCREEN

Touch a day. (Sunday is highlighted in this example).

2

Set the **On** times. Touch the hours, and then use the arrow buttons. Repeat for the minutes.

3

Set the **Off** times. Touch the hours, and then use the arrow buttons. Repeat for the minutes.

4

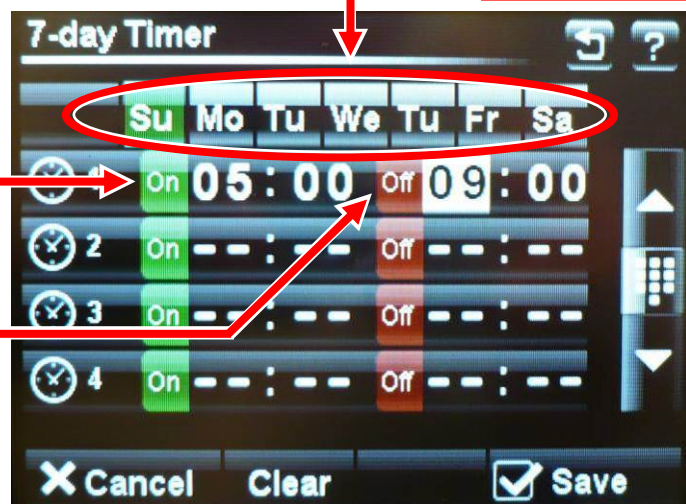

TIMER SETUP SCREEN

Repeat steps 2 to 4 for each required day. Touch **Save** to activate the 7-day timer.

5

Note:
 Up to four on/off times can be set for each day.
 Touch "clear" to clear the settings on the day shown.

Settings

OPTION SCREEN

Touch **Settings** to open the settings menu screen.

1



PASS CODE SCREEN

Enter the Supervisor pass code and then touch **OK**.

2

Note: Default code = 123456. This can be changed in the Settings menu).



Choose the settings to alter.

3

- Time & date page 40
- Start screen wallpaper page 40
- General settings page 41
- High level settings page 43
- Diagnostics page 49

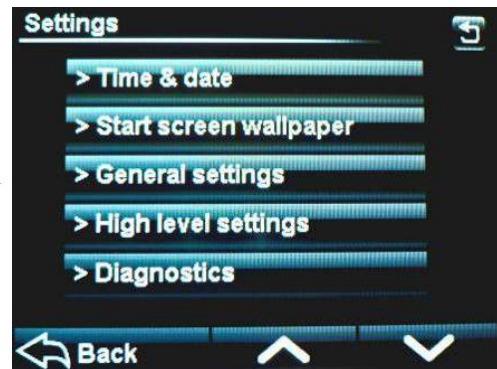

SETTINGS SCREEN

Set time and date

(Settings)

Touch the screen to highlight the item to be changed (e.g. "12" hours). **1**

TIME AND DATE SCREEN

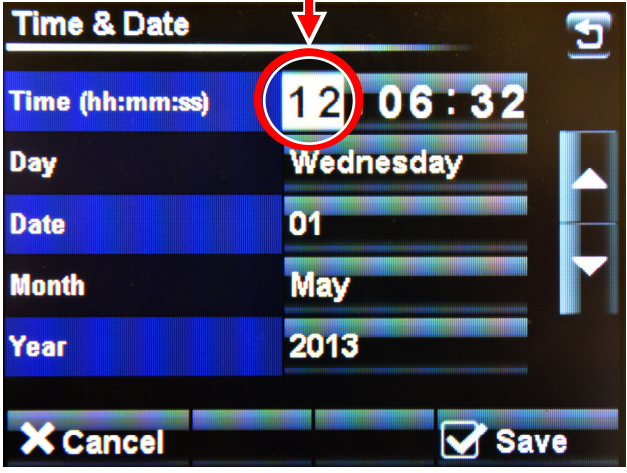

Use the **UP-ARROW** and **DOWN-ARROW** buttons to change the value of the item. **2**

Touch **Save** when the date and time are correct. The Settings menu will then open again. **3**

Select a wallpaper for the start screen

(Settings)

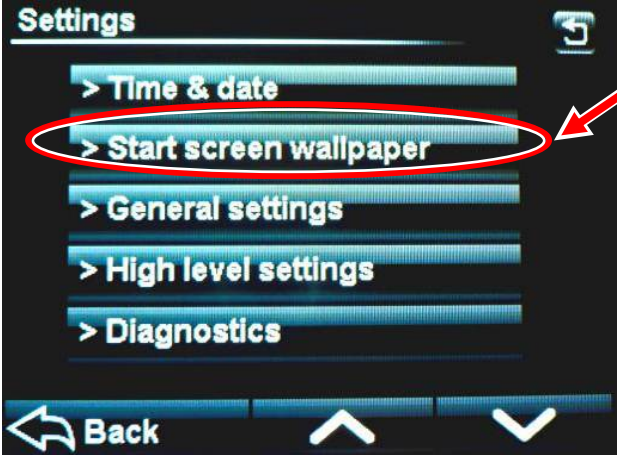

Touch **Start screen wallpaper**. **1**

Touch a wallpaper to select it. Touch **Back** to confirm. **2**



Use the arrow keys to see more wallpapers.

General oven settings

(Settings)

See **Table 5** for a guide to each oven setting.

Touch **General settings** to open the **Oven Settings** screen. **1**



SETTINGS SCREEN

Use the arrow buttons to scroll through all the options. Change each one as required. **2**

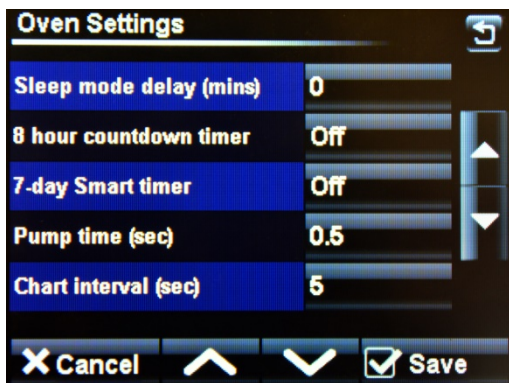
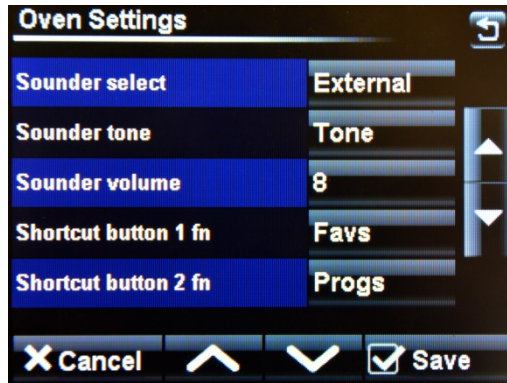
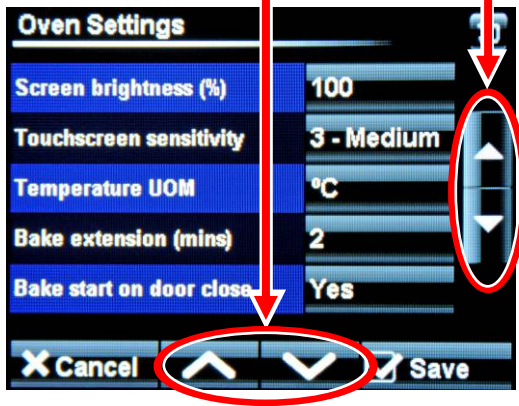

Table 5: Oven settings explained (general level)

Oven setting	Explanation of the settings	Default
Screen brightness	Adjusts the brightness level of the viewing screen. Settings are 5 to 100.	100
Touchscreen sensitivity	Adjusts the pressure required to operate the touch screen. (5 levels of sensitivity)	3 - Medium
Temperature unit of measure	Centigrade (Celsius) or Fahrenheit. Settings are °C and °F.	°C
Bake extension (minutes)	Adjusts the extra time at the end of a bake for each “extra time” button touch. Settings are 0 to 10 minutes.	2
Reselect product after bake	Resumes with the same product program without having to reselect it. Settings are Yes and No .	Yes
Sleep mode delay	The oven goes into sleep mode after the set minutes, providing it is up to temperature and has been through at least one bake cycle. Settings are 0 to 60 .	0
8-hour countdown timer	After 8 hours, the oven gives a warning and then turns off. Touch any button for an extra hour, if required. Off / On .	Off
7-day Smart timer	On = 7 -day timer function. Off = Controls set start time depending on oven temperature.	Off
Pump time (sec)	Increase pipe pressure before steaming. Settings 0.0 to 3.0 .	0.5
Chart interval (sec)	Time interval in seconds that the bars show on the heat and bake time progress charts. Settings are 1 to 60 .	5
Sounder select	Set as External or Onboard sounder.	External
Sounder tone	Select a tone – Voice , Tone , or Off .	Tone
Sounder volume	Adjust to suit the volume required for the onboard sounder. Settings are 0 to 15 .	8
Shortcut buttons 1 fn to 5 fn	It gives the choice of what buttons are active and in which order they appear on the options screen. Settings are Fav (Favourites), Progs (Programs), Manual bake, Multi bake, 7-Day timer, and [Blank] (not used). (Settings for 6 fn cannot be changed)	1 fn = Fav 2 fn = Progs 3 fn = Manual 4 fn = 7-Day 5 fn = [Blank]
Door open alarm	Turns the alarm on or off for when the door is opened during baking. Settings are On and Off .	On

High-level settings

(Settings)

See [Table 6](#) for a guide to the high-level settings.

SETTINGS SCREEN

1 Touch **High level settings** to open the settings screen.



2 Enter the High Level passcode and then touch **OK**.



PASSCODE SCREEN

3 The **High Level Settings** menu screen then appears. Use the arrow buttons to scroll through all the options. Change each one as required.

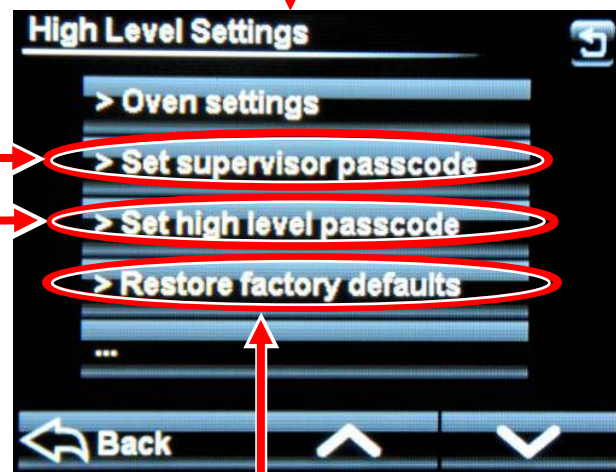

Change the Supervisor passcode

Change the High Level passcode

Touching **Oven settings** takes you to the settings menu. See [page 45](#) for guidance.

Restores all screens to original (factory default) settings

Table 6: Oven settings explained (high level)

Oven setting	Explanation of the settings	Default
Oven type	Always fixed to DX for this oven.	DX
Maximum bake temperature	It can be set from 250 °C (480 °F) up to 300 °C (572 °F) .	250 (°C) or 480 (°F)
Temperature offset	Adjusts the display of the actual temperature in the oven. Usually, this is kept set to 0 .	0
Bake hysteresis	Sets bake temperature cycling around a set point. (Above and below. Settings for above/below thresholds are 1 to 20).	2
Bake cycle setpoint only	No = Shows the set temperature point and actual temperatures on screen Yes = Shows the set temperature point only	No
Manual default temperature	Set for manual program default temperature.	150 (°C) or 302 (°F)
Sleep fallback	Set the temperature required to be maintained by the oven while sleeping. Setting are 100 to 200 (°C) / 212 to 392 (°F) .	170 (°C) or 338 (°F)
Sleep hysteresis	Keeps “sleep mode” temperature cycling around a set point. Settings for above/below thresholds are 1 to 20 (°C) .	2 (°C)
Ready accept high	The highest temperature for the oven to display “Ready”.	15
Ready accept low	The lowest temperature for the oven to display “Ready”.	-10
Steam type	Plate or Spray – but keep this set to Plate .	Plate
Top gain	Top and bottom heat gains. Settings are 0 to 255 °C (32 to 491 °F)	50 (°C) or 122 (°F)
Bottom gain		
Mono constant	Factory set. Do not change unless instructed to do so.	(Factory)
Steam trough temp.	<i>Not applicable to this oven.</i>	
Steam hysteresis	<i>Not applicable to this oven.</i>	
Steam trough accept	<i>Not applicable to this oven.</i>	
Light output soft start	Some lights need this for a cold start-up to stop them blowing.	Off
Heater control	Always fixed to the Contactor setting for this oven.	Contactor
I/P diagnostic	Displays inputs and outputs at the top of the screen to aid fault-finding.	Off

11. Using the USB port

 **Never use this USB port to power or recharge electronic devices e.g., mobile phones. Incorrect usage causes damage to the oven and could result in a fire.**

Ensure the start screen is showing. **1**

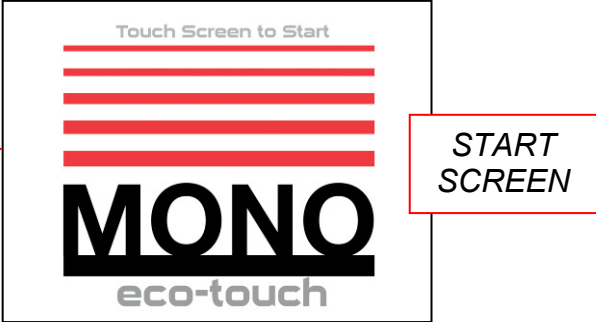

Insert the USB memory stick into the socket on the oven panel. (A rubber plug may have to be removed first).
Note:
 The USB stick only fits in one way.
Do not force it into the socket.

2



Wait for the USB symbol to finish moving.

3



If old firmware is found, the firmware version screen will appear.

4.1. Touch **OK** to update firmware.

4.2. Wait until the eco-touch controller has restarted after the update is complete.

4.3. Remove the USB stick or touch **Cancel** to choose other items to update or change. (See next page)

4

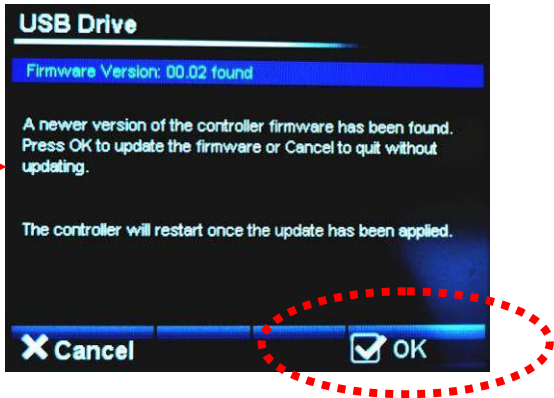

Other items to update

(Using the USB port)

Choose action you would like to do (e.g. **Load Products**).

5

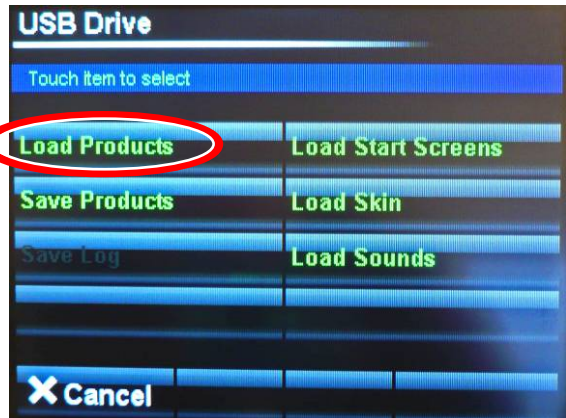

Select the file required (e.g. **MALEVOX**).

6



Remove the USB stick when confirmation of "file loaded ok" is seen.

7



Notes on using USB sticks

(Using the USB port)

For a USB stick (pen drive) to function correctly on a Mono oven with a port, it must have the following folder structure as a root folder.

Mono

(Create 5 sub-folders within the **Mono** folder)

Firmware

Products

Skins

Sounds

Startup

The oven automatically finds the **Mono** folder after plugging the USB stick into the port. Use any USB stick (as it does not need to be blank), but the Mono folder must be in the root.

Place your recipe and product files in the “**Products**” sub-folder. The most used sub-folders are **Product Files**, **Skins**, and **Startup Screens**.

SKINS

These files control the way the screen looks in different modes.

- **Pictorial** type skins are for when the screen displays categories using pictures.



- **Numerical** type skins are for when the screen displays categories using numbers.



PRODUCTS (PROGRAM FILES)

These files contain the information for baking each product, e.g. bread, buns, and cakes.

STARTUP SCREENS

These files show a picture or logo when the oven starts or wakes up.



12. Diagnostics

Touch **Settings** to open the settings menu screen.

1



OPTION SCREEN

Touch **Diagnostics** to open the diagnostics display.

2

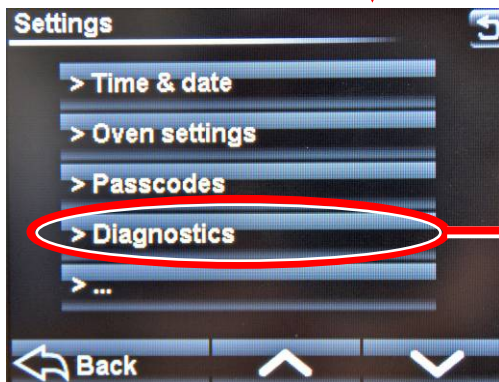

SETTINGS SCREEN

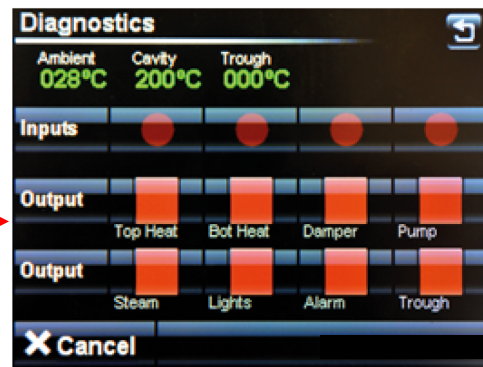

DIAGNOSTICS SCREEN

Inputs are highlighted when a signal is received, e.g. a door is open.

Touch the required output and a signal is sent to that item. The output being checked is highlighted when active. To stop the output, touch it again.

3

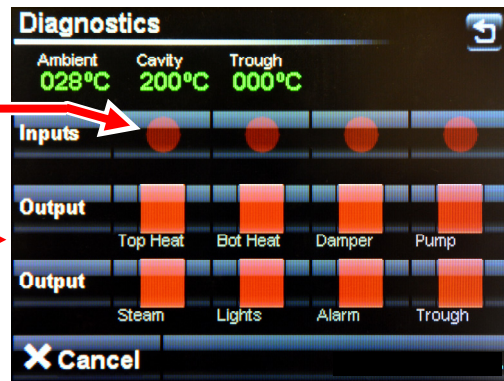

(Intentional Blank Page)

13. Passcodes

Default passcodes

Table 7: Security level and passcodes

Security level	Passcode
Supervisor (low level)	123456 (default)
High-level	654321 (default)
Master	314159 (fixed)

To stop unauthorised changes to the oven setup, it is suggested that this section is removed from this manual and kept in a safe place for future reference.

If tampering could be a problem, it is a good idea to change the passcodes at regular intervals.

How to change the passcodes

Note: Passcodes are required to navigate through these screens and make changes.

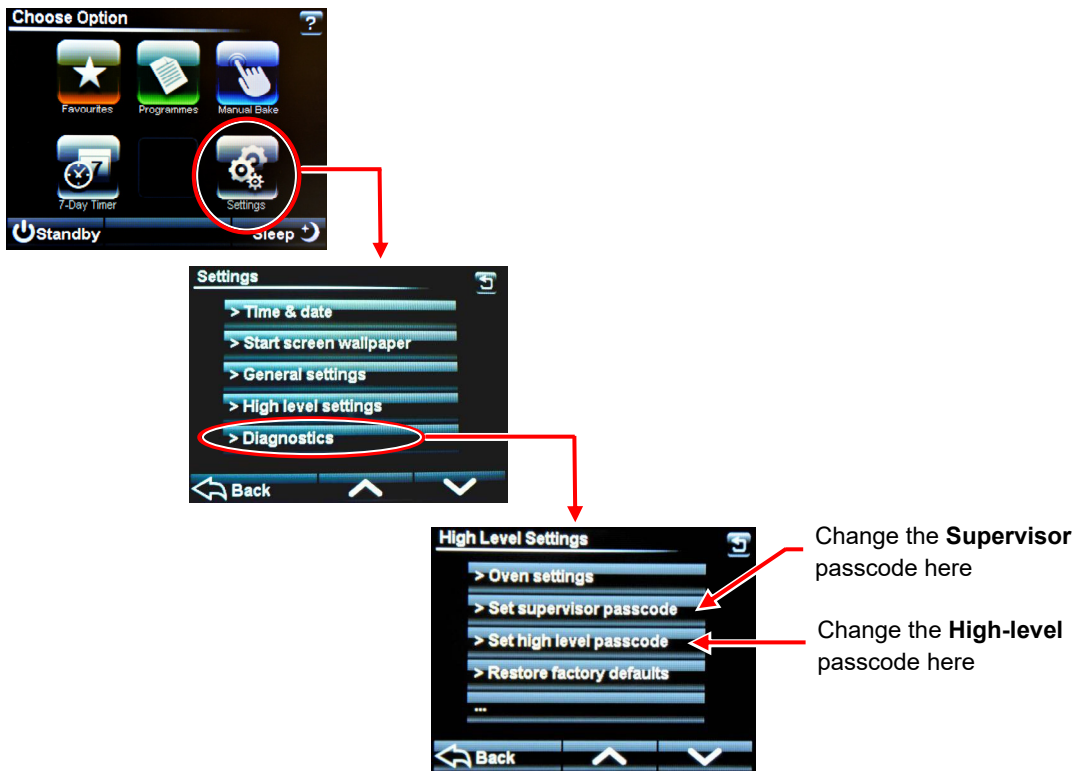

14. Troubleshooting

None of the decks switched on

- Is the oven's main isolator set to the on (I) position?
- Check if a time clock of the bakery's mains power supply is working (if fitted).
- Is the clock set correctly to power the oven at the required day and time?

One deck has not switched on

- Check if the individual deck timer is to come on at a specific time.

Uneven or patchy bake

- The deck door is open too often or too long whilst loading (front pale, back burnt).
- Uneven loading.
- Faulty element.
- Top or bottom deck elements are not functioning.
- No supply voltage across a phase.

Actual temperature is far exceeding the set temperature

When empty, the temperature of a deck oven can exceed the set baking temperature. This overheat is marginal when the deck is full of product. If the elements are continuing to work after the set temperature has been reached, call MONO service.

(Please allow up to 15 °C (59 °F) difference before diagnosing a fault condition).

Poor recovery of actual temperature after loading

- Doors may have been left open too long during loading, allowing heat to escape.
- Damper may have been left open during loading/baking, allowing heat to escape.
- Top or bottom heat may not be working.
- No supply voltage across a phase.

Steam system not operating correctly







- Is water connected correctly?
- Is the tap to each deck in the on position?
- Has enough time elapsed since the last steaming?

Once steamed, the oven does not steam until the steam unit has recovered heat, typically 3 to 10 minutes depending on the program selected.

15. Service and Spares

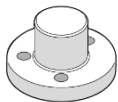
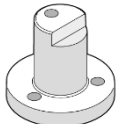
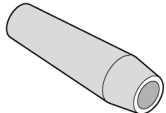
Oven spares

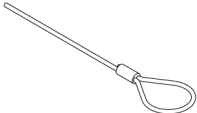
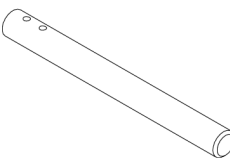
Table 8: Oven spares

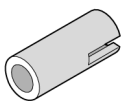
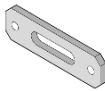
Spare		Part number
Frosted glass (lights)		257-02-00027
Plain glass (lights)		257-02-00028
Door bumper stop		257-03-00094
Hinge pin, right-hand-side		257-03-00005
Hinge pin, left-hand-side		257-03-00009
Black door handle		A900-27-192
Door spring		257-03-00017
Wire rope		257-03-00024
Spring retaining pin		257-03-00025
Pulley		257-03-00015
Pulley spindle		257-03-00013
Damper drive coupling		257-07-00007
Element gasket		245-02-01300

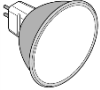
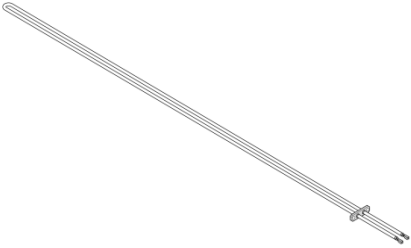
Spare		Part number
24v 20w Dichroic Lamp		B855-94-008
Top heat element, 0.66 kW Top heat element, 0.4 kW Bottom heat element, 0.5 kW		B854-04-102 B854-04-100 B854-04-101

Service information

If a fault arises, please do not hesitate to contact the MONO Customer Service Department. Quote the machine serial number on the silver information plate of the machine and on the front cover of this manual.

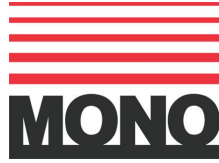

MONO Equipment

Queensway, Swansea West Industrial Park, Swansea, SA5 4EB UK

Tel. 01792 561234

Spares +44(0)1792 564039

Email: mono@monoequip.com

www.monoequip.com

Disposal

When the oven comes to the end of its working life, dispose of parts in the appropriate place by recycling or other means as the law permits at that time.

16. Maintenance

General maintenance



WARNING

- This appliance must be maintained at regular intervals. The frequency of maintenance will depend upon your specific use and location. The maximum service interval should be 12 months.
- Service and maintenance should only be undertaken by suitably qualified, trained, and competent engineers.
- You must immediately report any damage or defect arising with the appliance.
- Unsafe equipment is dangerous. Do not use the appliance. Isolate the power supply and contact MONO or your appointed service agent.

- Check for frayed or bare cables.
 - Do not use the machine if frayed or bare cables are visible.
- Follow cleaning instructions (see **Cleaning** on page 18).

Light bulb replacement



WARNING Disconnect from the supply before replacing light bulbs.

How to replace the 24Vac 20w lamp (part number B855-94-008)

1. Unscrew the plate (A) next to the light to be replaced.
 - Keep the hex head socket screws (B) safe.

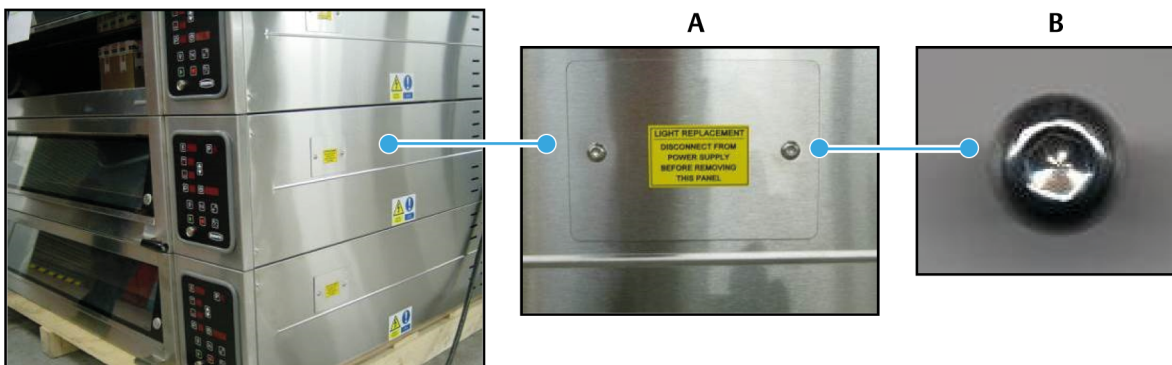

2. Slide the fitting out.



3. Remove the light from the holding slot and unclip from the cable.



4. Replace the light and refit all parts.



5. Reconnect the power supply and test.

17. Oven Electrics

Table 9: Parts list for the electrical drawings (3-tray wide)

Reference in drawing	Description	Part number
F1 (single-phase only)	Heaters MCB	B872-22-007
F2 (single-phase only)	Heaters MCB	B872-22-007
F3 (single-phase only)	Heaters MCB	B872-22-007
F4	Control power supply MCB	B872-22-062
F5	Overheat thermostat	B888-30-014
T1	Control circuit power supply	B801-93-005
K1	Top heat contactor	B801-08-021
K2	Bottom heat contactor	B801-08-021
Y1	Water solenoid (8 mm pipe)	A900-34-365
H1	Interior light	B855-94-008
B1	Oven thermocouple	B873-95-007
U1	Main ECO printed circuit board	158-25-80000
D1	Damper solenoid	B749-83-004
R1	Top heat element, 1.0 kW	B854-04-093
R2	Top heat element, 0.6 kW	B854-04-091
R3	Top heat element, 0.6 kW	B854-04-091
R4	Top heat element, 0.6 kW	B854-04-091
R5	Top heat element, 0.6 kW	B854-04-091
R6	Top heat element, 0.6 kW	B854-04-091
R7	Top heat element, 0.6 kW	B854-04-091
R8	Bottom heat element, 0.75 kW	B854-04-092
R9	Bottom heat element, 0.6 kW	B854-04-091
R10	Bottom heat element, 0.6 kW	B854-04-091
R11	Bottom heat element, 0.6 kW	B854-04-091
R12	Bottom heat element, 0.6 kW	B854-04-091
R13	Bottom heat element, 0.6 kW	B854-04-091
R14	Bottom heat element, 0.6 kW	B854-04-091

Table 10: Parts list for the electrical drawings (2-tray wide)

Reference in drawing	Description	Part number
F1 (single-phase only)	Heaters MCB	B872-22-006
F2 (single-phase only)	Heaters MCB	B872-22-006
F3 (single-phase only)	Heaters MCB	B872-22-006
F4	Control power supply MCB	B872-22-062
F5	Overheat thermostat	B888-30-014
T1	Control circuit power supply	B801-93-005
K1	Top heat contactor	B801-08-021
K2	Bottom heat contactor	B801-08-021
Y1	Water solenoid (8 mm pipe)	A900-34-365
H1	Interior light	B855-94-008
B1	Oven thermocouple	B873-95-007
U1	Main ECO printed circuit board	158-25-80000
D1	Damper solenoid	B749-83-004
R1	Top heat element, 0.65 kW	B854-04-102
R2	Top heat element, 0.4 kW	B854-04-100
R3	Top heat element, 0.4 kW	B854-04-100
R4	Top heat element, 0.4 kW	B854-04-100
R5	Top heat element, 0.4 kW	B854-04-100
R6	Top heat element, 0.4 kW	B854-04-100
R7	Top heat element, 0.4 kW	B854-04-100
R8	Bottom heat element, 0.5 kW	B854-04-101
R9	Bottom heat element, 0.4 kW	B854-04-100
R10	Bottom heat element, 0.4 kW	B854-04-100
R11	Bottom heat element, 0.4 kW	B854-04-100
R12	Bottom heat element, 0.4 kW	B854-04-100
R13	Bottom heat element, 0.4 kW	B854-04-100
R14	Bottom heat element, 0.4 kW	B854-04-100

Electrical drawings

TOP CANOPY MK 2 DECK OVEN MCB WIRING

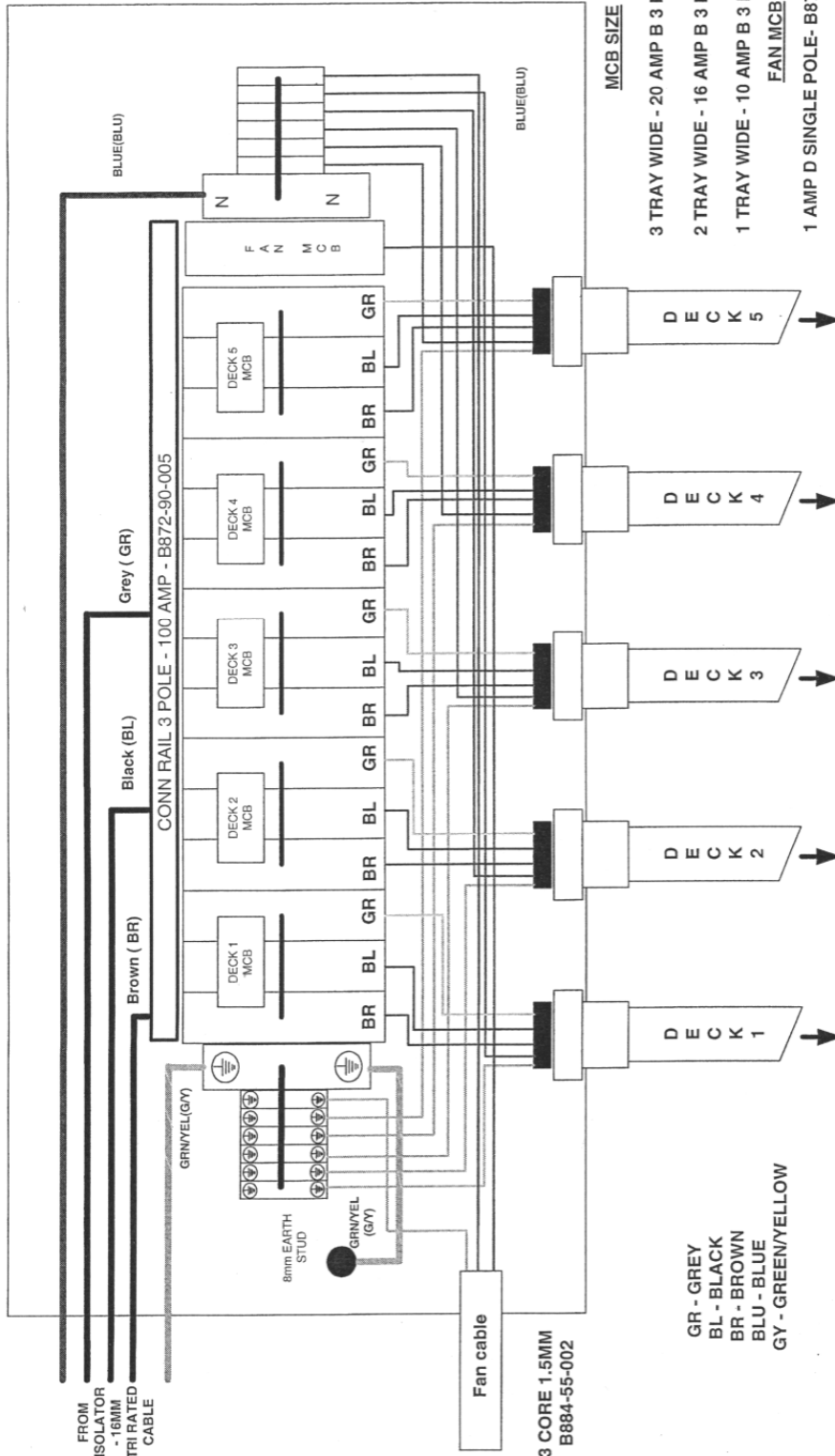

- MCB SIZE**
- 3 TRAY WIDE - 20 AMP B 3 POLE- B872-22-027
 - 2 TRAY WIDE - 16 AMP B 3 POLE- B872-22-026
 - 1 TRAY WIDE - 10 AMP B 3 POLE- B872-22-025
- FAN MCB**
- 1 AMP D SINGLE POLE- B872-22-060

MONO EQUIPMENT QUEENSWAY SWANSEA, WEST MIDLANDS SA5 4EB MONO Email: engineering@monoequipment.com	TITLE: UK/EUROPE TOP SECTION MCB WIRING DISTRIBUTION UNIT	
	DRAWN: ADT	ELECTRICALLY APPROVED BY: ADT
ELECTRICAL SPECIFICATIONS: 400V 50/60 HZ 3 PHASE + N+E		DATE: 19-2-07 DRAWING NO: M257E25-52300 REV: -

MAINS CABLE TO EACH DECK (TB1) 2.5MM 5 CORE TYPE B B843-57-003

GR - GREY
 BL - BLACK
 BR - BROWN
 BLU - BLUE
 GY - GREEN/YELLOW

DX UK Modular MK2 Deck Oven Interlink Detail

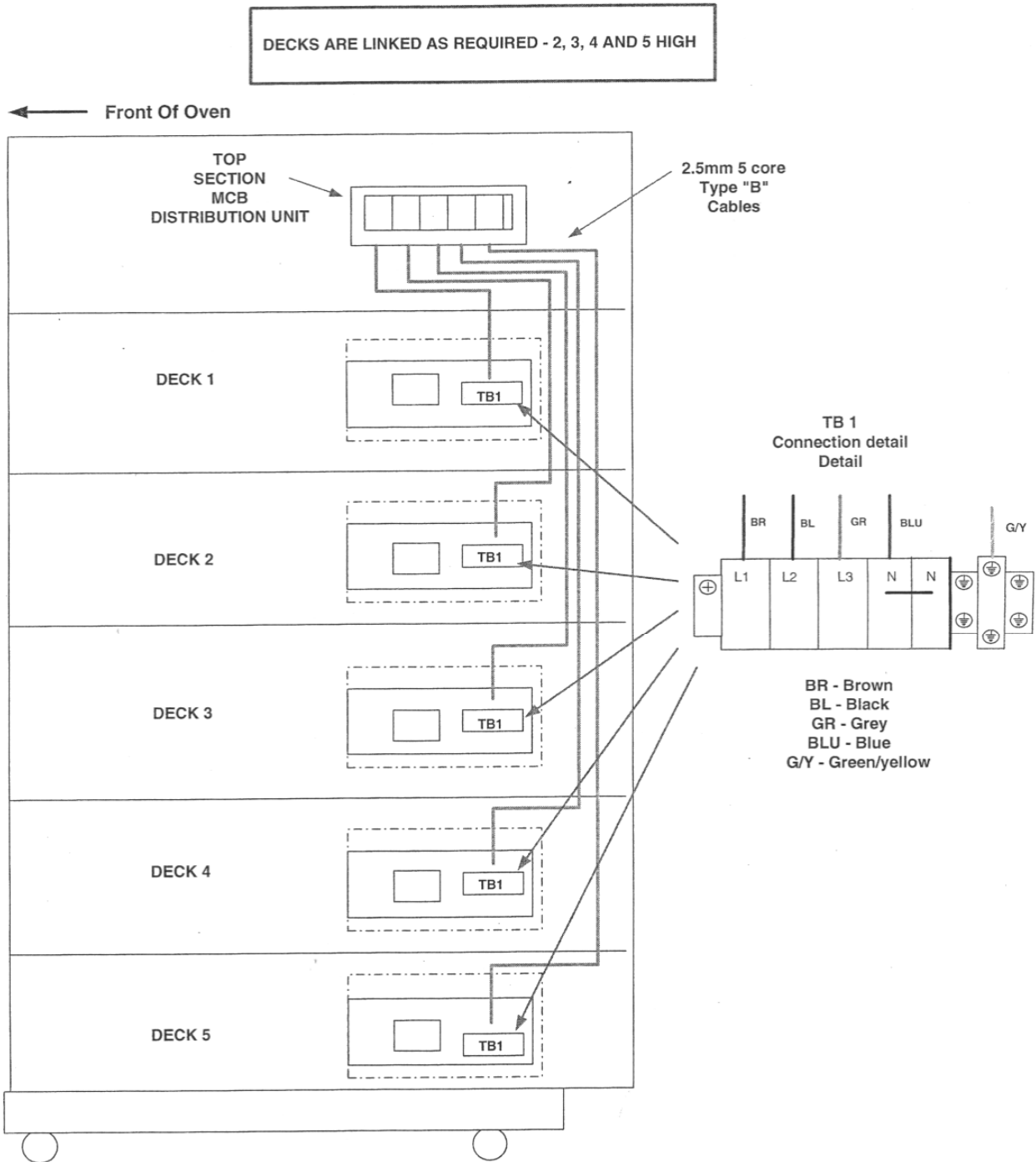

<p>MONO EQUIPMENT QUEENSWAY SWANSEA WEST IND PARK SWANSEA SA4 4EB TEL: (01792) 561234 FAX: (01792) 561016 Email: engineering@monoequip.com</p>	TITLE: UK/EUROPE MODULAR MK 2 DECK OVEN INTERLINK DETAIL		
	ELECTRICAL SPECIFICATIONS: 400V 50/60 HZ 3 PHASE + N+E	DRAWING: ADT	ELECTRICALLY APPROVED BY: ADT
	DATE: 19-2-07	DRAWING NO. M257E25-52500	REV: -

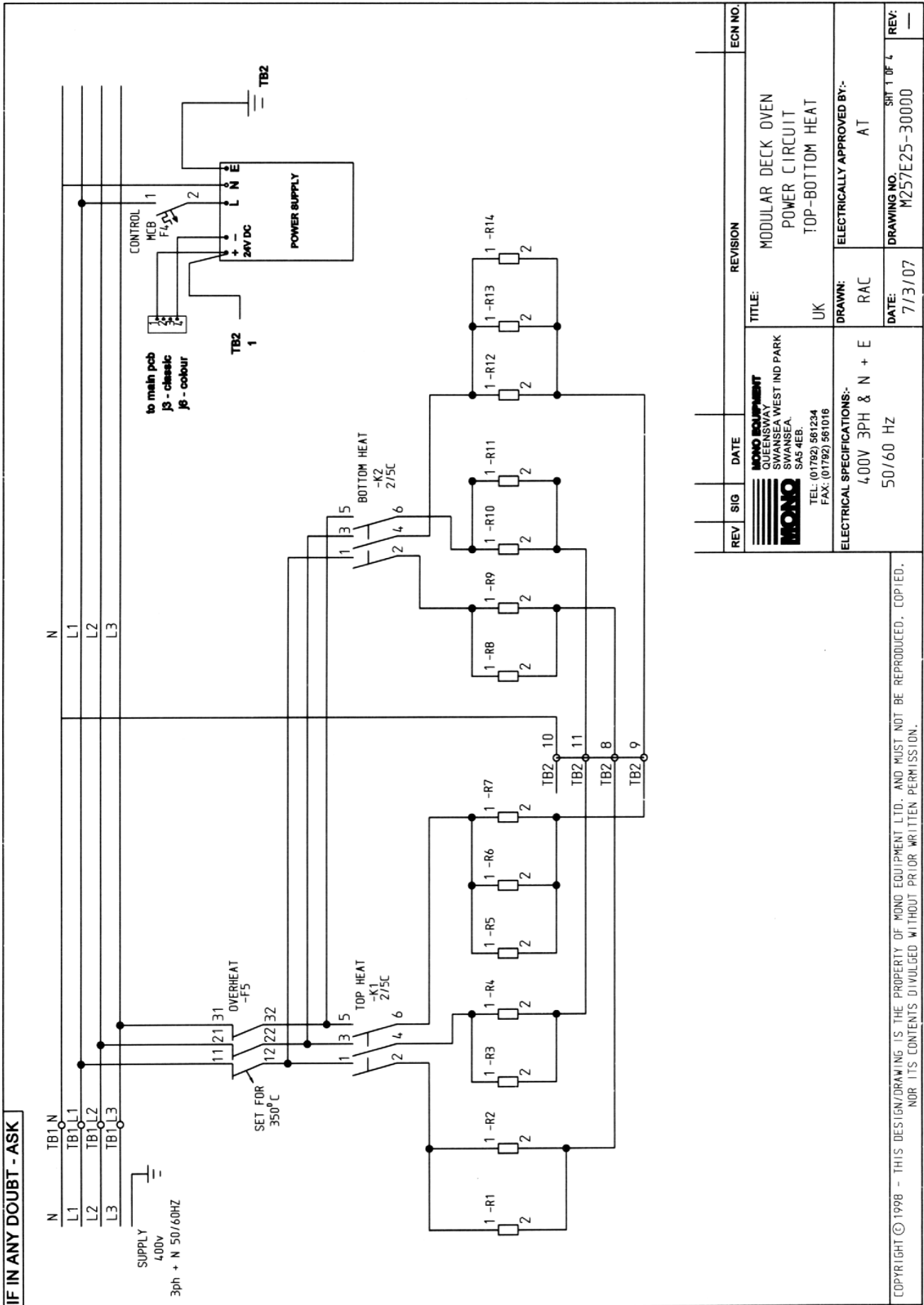

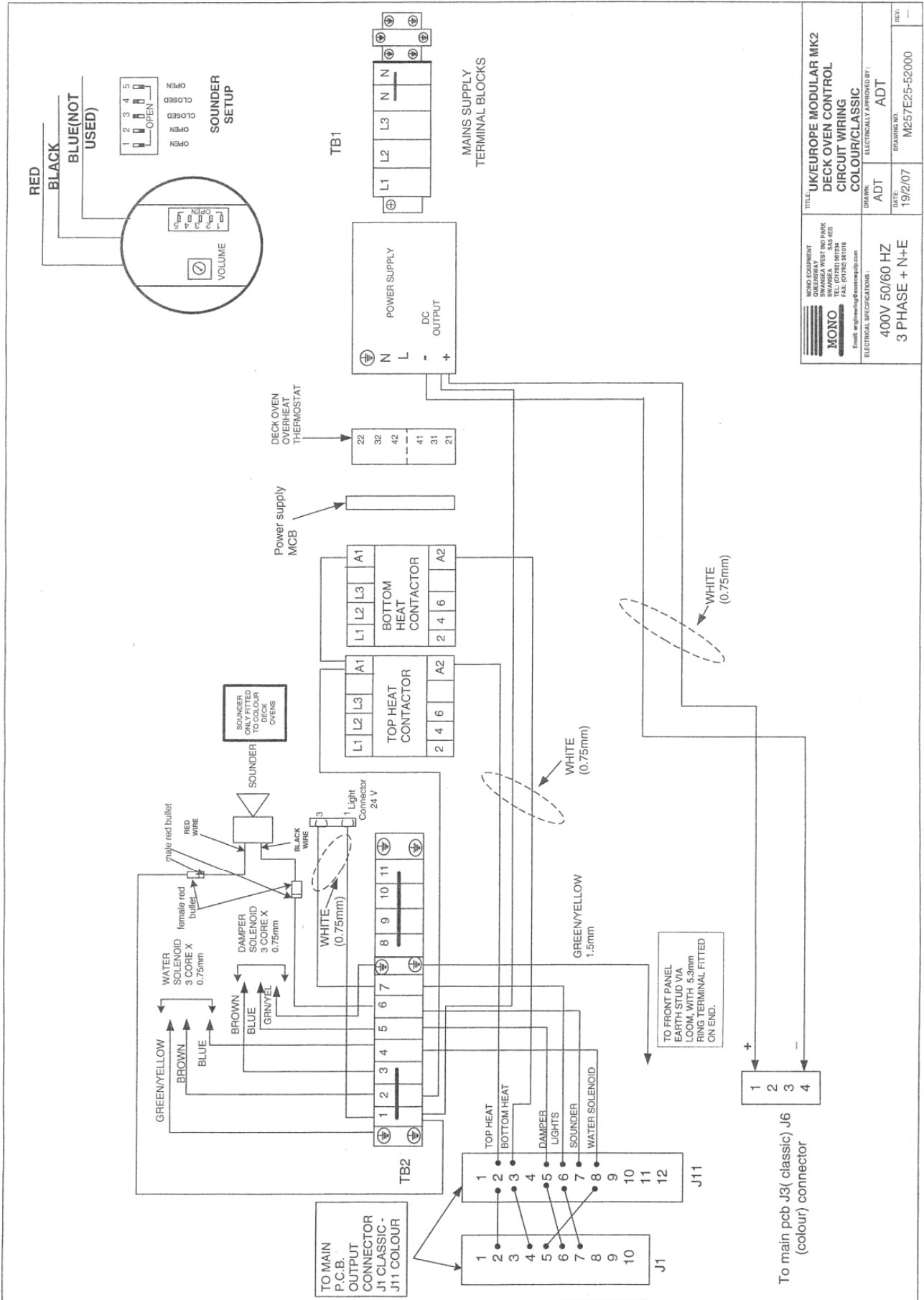

<p>MONO EQUIPMENT SWANSEA WEST IND PARK SWANSEA SA1 8ED TEL: (01792) 961534 FAX: (01792) 961616 Email: engineering@monoequip.com</p>	<p>TITLE: UK/EUROPE MODULAR MK2 DECK OVEN CONTROL CIRCUIT WIRING COLOUR/CLASSIC</p>	
	<p>DRAWN: ADT</p>	<p>ELECTRICALLY APPROVED BY: ADT</p>
<p>400V 50/60 HZ 3 PHASE + N+E</p>	<p>DATE: 19/2/07</p>	<p>DRAWING NO: M257E25-52000</p>
<p>REV: ---</p>		<p>REV: ---</p>

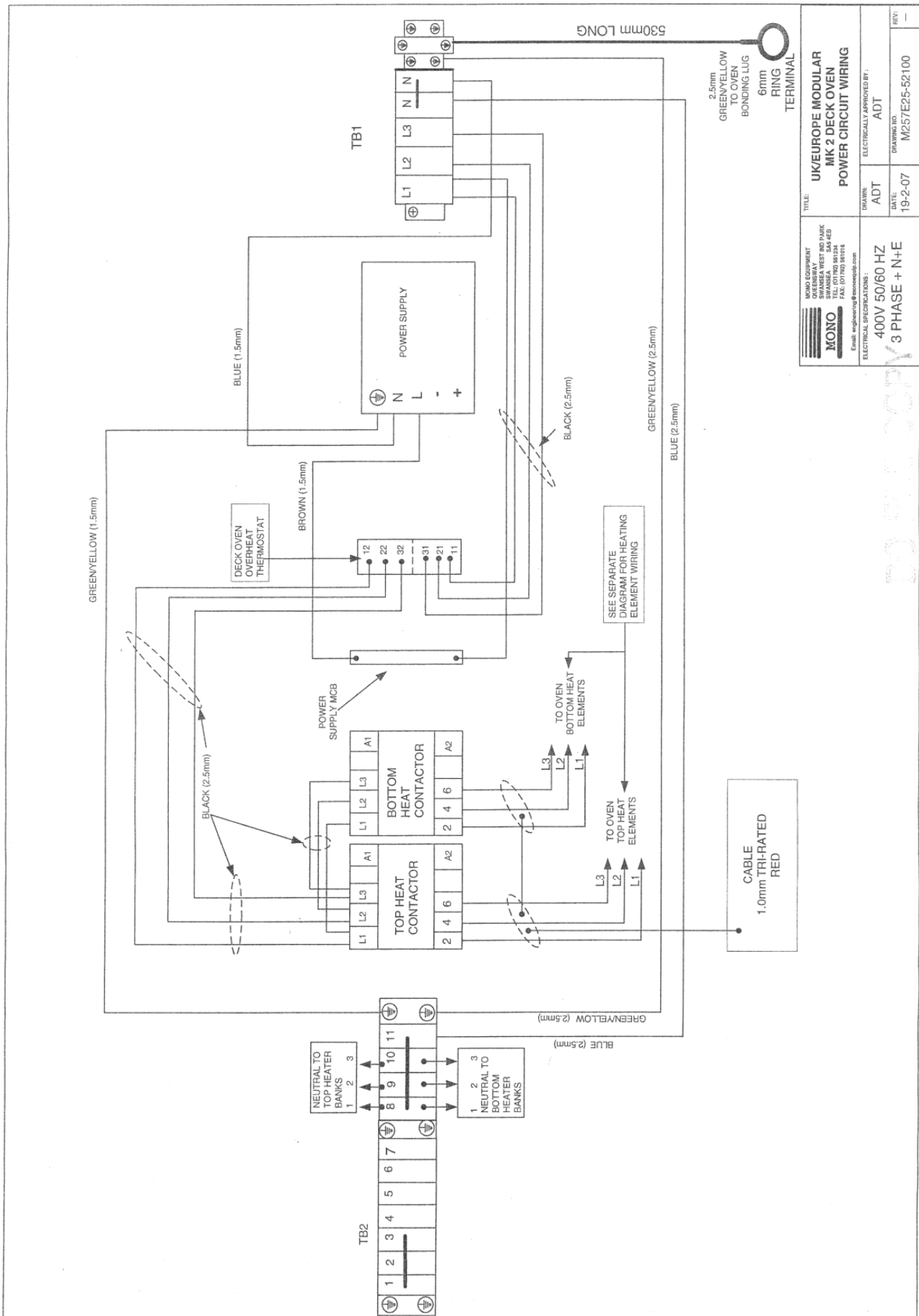

 MONO Email: engineering@monocontrols.com	TITLE: UK/EUROPE MODULAR MK 2 DECK OVEN POWER CIRCUIT WIRING	DRAWN: ADT DATE: 19-2-07	ELECTRICALLY APPROVED BY: ADT DRAWING NO: M257E25-52100
	MAKE & EQUIPMENT SWANSEA WEST IND PARK GLENSIDE SWANSEA SA1 8ED TEL: (01792) 803204 FAX: (01792) 803216	ELECTRICAL SPECIFICATIONS: 400V 50/60 HZ 3 PHASE + N+E	REV: —

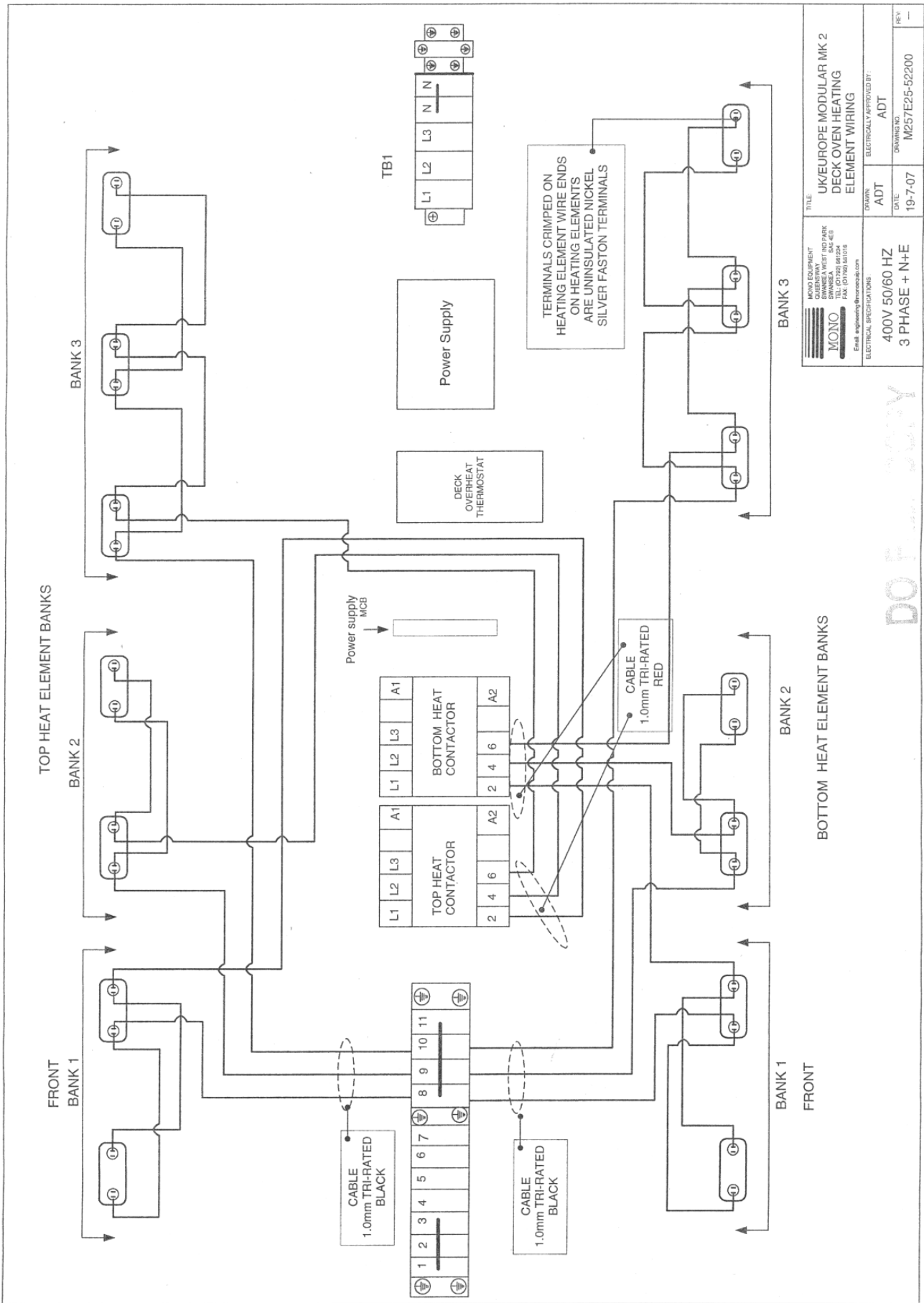

DO F...
...
...
...
...

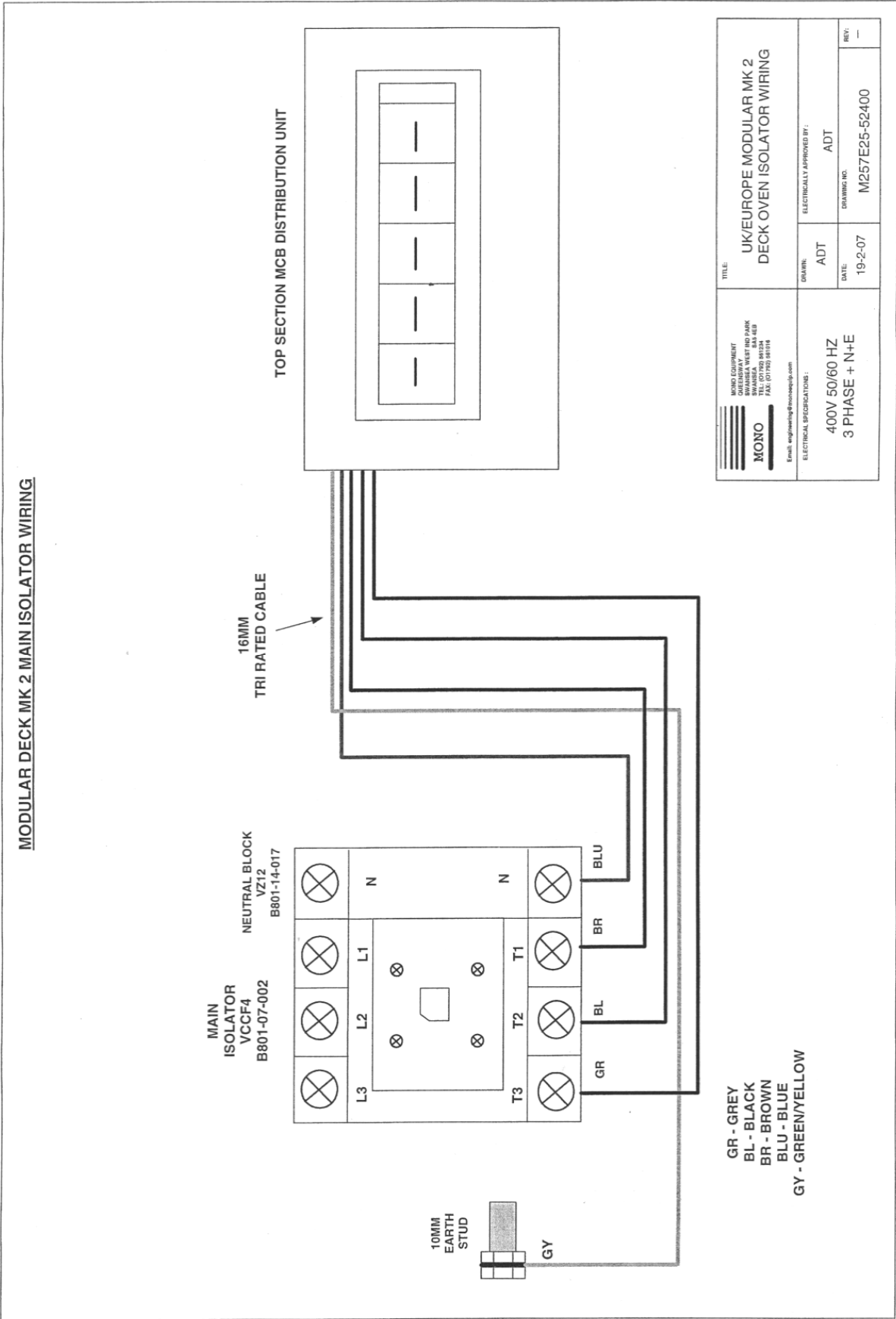

Electrical panel main components

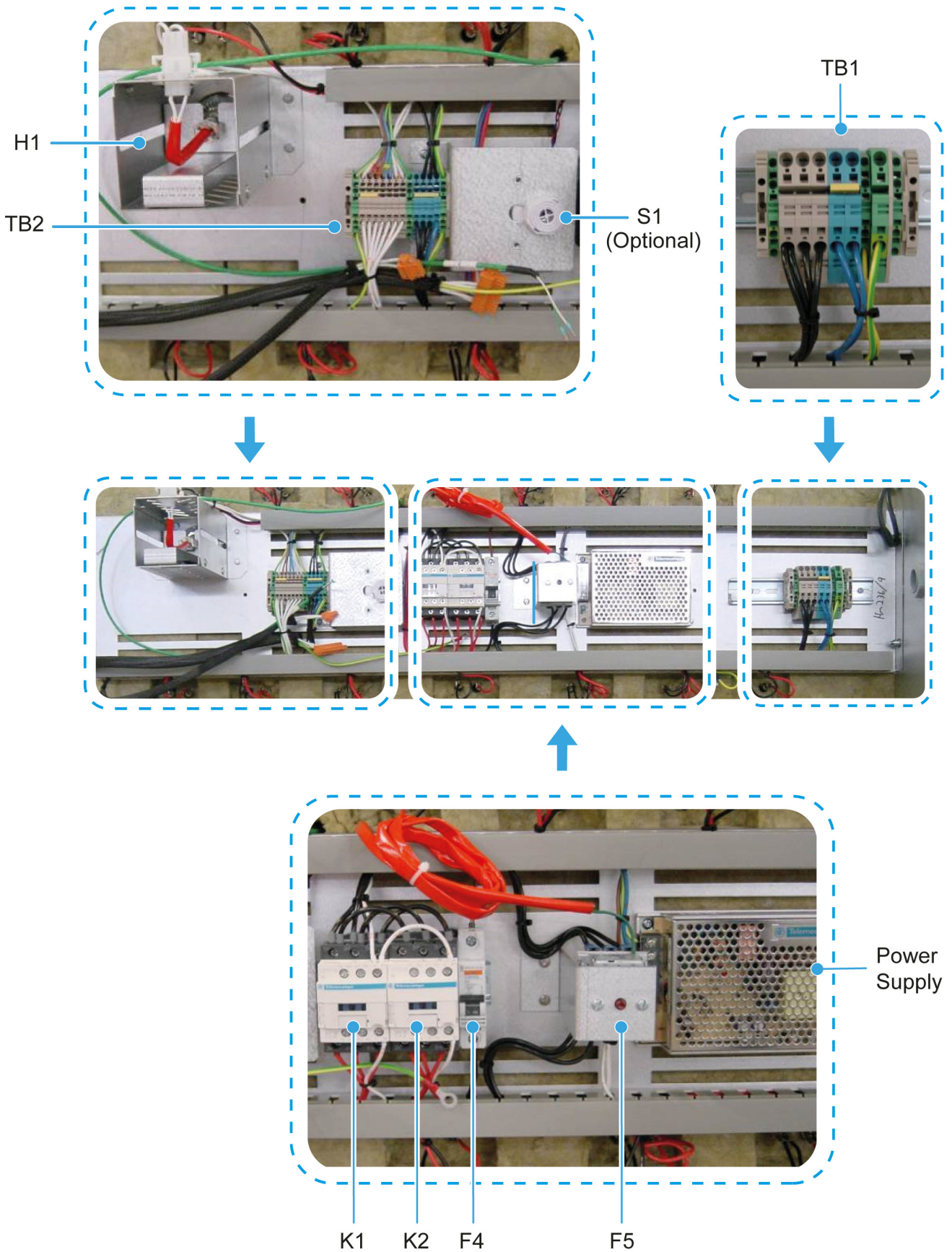

Table 11: Oven canopy layout parts list

Reference	Part description	Part number
C1	Canopy fan capacitor, 5 μ F, 400VDB, metal	B869-23-005
Q1	Canopy fan on/off switch	B895-07-005
M1	Canopy fan motor R2E225-AG01-21 (230V, 1.4 Amp, 305 Watts)	B869-75-026

18. Prover operating instructions

Note

It is the customer's responsibility to install and maintain an adequate water supply.

Customers operating the prover in hard water areas must ensure that an efficient water treatment device protects the water supply to the prover. -- **MONO is happy to advise on a suitable unit --**

Prover controls

1. Ensure the water (washing machine type hose) is connected at the rear and the power is connected to a suitable socket.
2. Turn the power switch (A) to "dry" or "steam"
(“Dry works like a hot cupboard and “steam” adds humidity (85%) and heat).
3. Turn the temperature-setting button (B) to the required temperature; usually about 40 degrees.
The heat indicator light (C) will come on.
4. When the light goes out it means the prover is ready for use.
(Usually about 30 minutes, depending on the ambient temperature)

Note

To maintain the humidity level within the cabinet, the doors should only be opened for a short time.



19. Prover electrics

Electrical drawings

DX PROOVER REAR TERMINAL BLOCK TB2

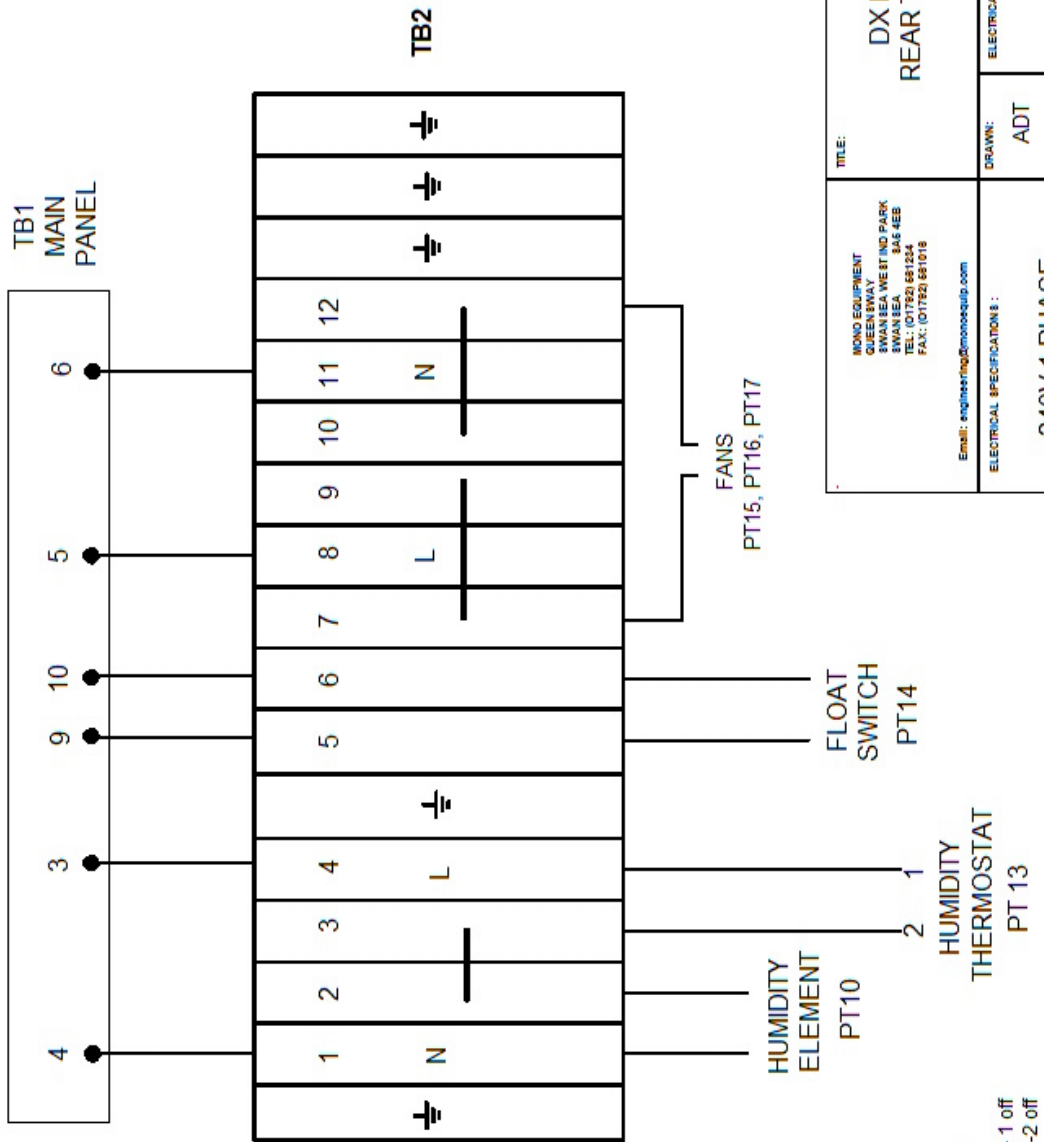

- WPE4-Earth B852-86-005 - 5 off
- WDU4 Beige -- B852-50-013 - 8 off
- WDU4 Blue -- B852-50-012 - 4 off
- 2 Way cross conn unit - B852-13-030 - 1 off
- 3 Way cross conn unit - B852-13-032 - 2 off

MONO EQUIPMENT QUEENSWAY SWANSEA WEST END PARK SWANSEA SA4 4EE TEL: (01792) 681216 FAX: (01792) 681018 Email: engineering@mono.co.uk		TITLE: DX PROVER REAR TB2 DETAIL	
ELECTRICAL SPECIFICATIONS: 240V 1 PHASE 50HZ		DRAWN: ADT	ELECTRICALLY APPROVED BY: ADT
		DATE: 7/3/18	DRAWING NO. 257E25-10100
		REV: —	

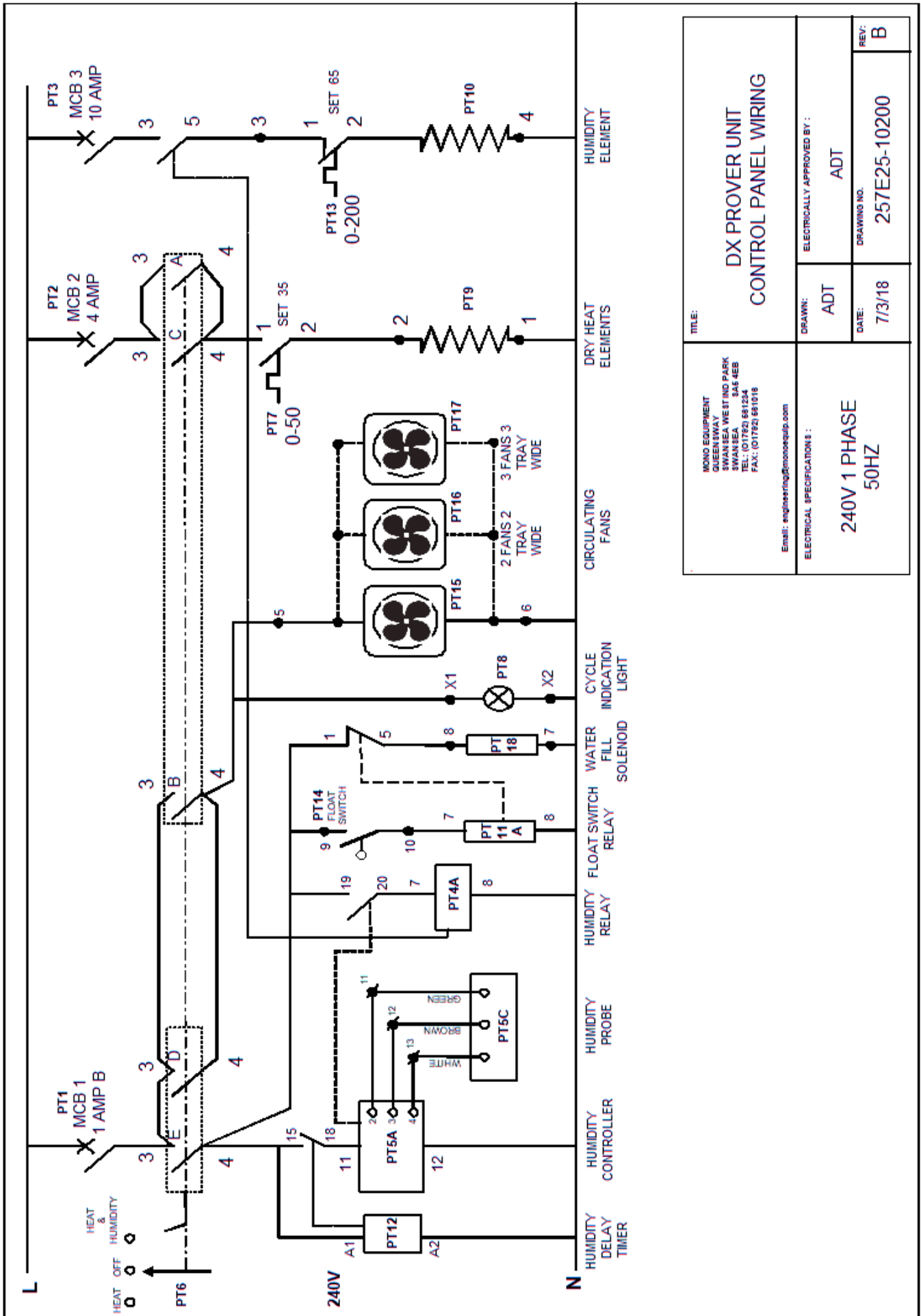

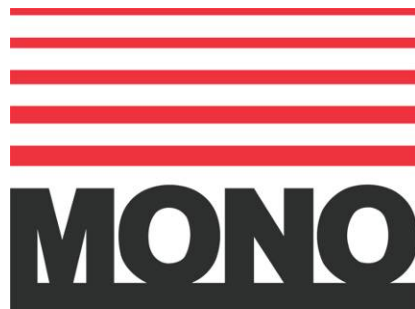

MONO Equipment

Queensway, Swansea West Industrial Park, Swansea, SA5 4EB UK

Tel. 01792 561234

Spares +44(0)1792 564039

Email: mono@monoequip.com

www.monoequip.com

As it is our policy to improve our machines continuously, we reserve the right to change specifications without prior notice.