



Enter **Serial No.** here _____
In the event of an enquiry please quote this serial number.



OPERATING AND MAINTENANCE MANUAL

AZTEC DOUGHNUT FRYER

Failure to adhere to the cleaning and maintenance instructions detailed in this booklet could affect the warranty of this machine.

IMPORTANT NOTE

Special attention should be given to the bottom of the top tank so that a layer of sediment is not allowed to build up. If the sediment does build up a fire could result as the temperature sensors will not be able to function correctly.

Do not mix different makes or types of frying oil as a reaction can result in a thick flour-like sediment forming in the lower tank which can block the filtering system.

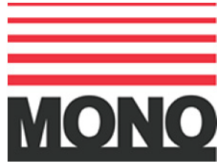

DECLARATION OF CONFORMITY

We hereby declare that this machine complies with the essential health and safety requirements of :-

- The Machinery Directive 2006 / 42 / EC
- The Low voltage Directive 2006 / 95 / EC
- The requirements of the Electromagnetic Compatibility Directive 2004 / 108EC, 91 / 263 / EEC, 92 / 31 / EEC
- The General Safety of Machinery and food processing Standards applicable
- Materials and Articles intended to come into contact with food - Regulation (EC) No. 1935 / 2004
- Good manufacturing practice for Materials intended to come into contact with food - Regulation (EC) No. 2023 / 2006

Signed	
D. Osmundsen – Quality and Conformance Manager	

Date	
-------------	--

Machine FG Code.		Machine Serial No.	
-----------------------------	--	-------------------------------	--

A technical construction file for this machine is retained at the following address:

MONO EQUIPMENT
Queensway,
Swansea West Industrial Park,
Swansea
SA5 4EB
UK

MONO EQUIPMENT is a business name of **AFE GROUP Ltd**
Registered in England No.3872673 VAT registration No.923428136

Registered office: Unit 35,
Bryggen Road,
North Lynn Industrial Estate,
Kings Lynn Norfolk,
PE30 2HZ

SAFETY SYMBOLS

The following safety symbols are used throughout this product documentation and manual (available at www.monoequip.com).

Before using your new equipment, read the instruction manual carefully and pay special attention to information marked with the following symbols.



WARNING

Indicates a hazardous situation which, if not avoided, will result in death or serious injury.



WARNING

Indicates a hazardous situation which, if not avoided, will result in electric shock.



CAUTION

Indicates a hazardous situation which, if not avoided, will result in minor or moderate injury.

**DO NOT POUR USED OIL
DOWN DRAINS OR SINKS.**



IMPORTANT NOTES



Special attention should be given to the bottom of the top tank so that a layer of sediment is not allowed to build up. As the temperature sensors will not be able to function correctly, a fire could result.

Do not mix different makes or types of frying oil as a reaction can result in a thick flour-like sediment forming in the lower tank which can block the filtering system.



ELECTRICAL SAFETY AND ADVICE REGARDING SUPPLEMENTARY ELECTRICAL PROTECTION

Commercial kitchens and food service areas are environments where electrical appliances may be located close to liquids or operate in and around damp conditions or where the restricted movement for installation and service is evident.

The installation and periodic inspection of the appliance should only be undertaken by a qualified, skilled and competent electrician, and connected to the correct power supply suitable for the load as stipulated by the appliance data label.

The electrical installation and connections should meet the necessary requirements of the local electrical wiring regulations and any safety guidelines.

We recommend:-

- Supplementary electrical protection with the use of a Residual Current Device (RCD)
- Fixed wiring appliances should also incorporate a locally situated switch disconnector to connect to, which is easily accessible for switching off and safe isolation purposes. The switch disconnector must meet the specification requirements of IEC 60947.

Your attention is drawn to:-

BS 7671:2018 – Guidance Note 8 – 8.13: Other locations of increased safety risk

It is recognised that there may be locations of increased risk of electrical shock other than those specifically addressed in Part 7 of BS 7671. Examples of such locations could include laundries where there are washing and drying machines in close proximity and water is present, and commercial kitchens with stainless steel units, where once again, water is present. Where, because of the perception of additional risks being likely, the installation designer decides that an installation or location warrants further protective measures, the options available includes:

- Automatic Disconnection of Supply (ADS) by means of a residual current device having a residual operating current not exceeding 30 mA;
- Supplementary protective equipotential bonding; and
- Reduction of maximum fault clearance time.

The provision of RCDs and supplementary bonding must be specified by the host organisation's appointed installation designer or electrical contractor and installed by a suitably qualified and competent electrician so as to comply with Regulations 419.2 and 544.2.



The supply to this machine must be protected by a **30mA RCD**



Safety during emptying and cleaning of fryers

HSE information sheet

Introduction

This information sheet was produced by the Hospitality and Catering Industry Liaison Forum, which has members from trade and professional associations, unions and enforcement authorities. Members' associations are free to reproduce and distribute this guidance to catering establishments. The guidance is issued by the Health and Safety Executive.

This sheet provides advice to employers in the catering industry on safe emptying and cleaning of fryers. It gives guidance on manual emptying and cleaning and guidance on fryers with automated or semi-automated filtering (using enclosed portable filtering units).

Automated and semi-automated filtering processes avoid operators coming into contact with hot oil, significantly reducing the risks. This enables filtering to take place safely even while the oil is at normal cooking temperature. Most automated or semiautomated systems require an oil temperature of at least 100 °C for the filtering process to work effectively.

You should only carry out manual emptying and filtering of fryers when the oil has been cooled to 40 °C or below.

Key messages

- Burns from hot oil can be very serious.
- Oil takes only 6–7 minutes to heat up but can take 6–7 hours to cool down again.

What the law says

The Health and Safety at Work etc Act 1974 (the HSW Act) places a duty on employers to ensure, so far as reasonably practicable, the health, safety and welfare of their employees. This duty extends, amongst other things, to providing and maintaining systems of work which are, so far as reasonably practicable, safe and without risks to health. The HSW Act also places a duty on employees to take reasonable care of their own and others' health and safety.

Whichever type of fryer is used, you must:

- ensure the fryer is well maintained and any attachments used are suitable for their purposes, as recommended by the manufacturer – a procedure for reporting faults will help you comply with this duty;
- train staff in a safe system of work for emptying and cleaning;
- provide staff with suitable protective equipment where required by the risk assessment, eg eye protection, heat-resistant gloves, aprons.

When to empty and clean

■■ Many catering establishments are closed overnight. For fire safety and economy switch off fat fryers when unattended. Carry out oil filtering and cleaning as a **first task of the day rather than as part of the closing-down procedure.**

Hazards

The hazards in emptying and cleaning fryers include:

- fire;
- burns from hot oil;
- contact with hot surfaces;
- fumes from boiling cleaning chemicals;
- boiling chemicals overflowing;
- eye injuries from splashes;
- slips from oil spillage;

■ ■ strains and sprains from lifting and moving containers of oil. If the catering service runs for 24 hours and the appliance is required continuously, there are two safe options:

Health and Safety Executive

Page 2 of 4

■ ■ Use more than one fryer and clean them in rotation.

■ ■ Use an automated filtering system or a semiautomated portable filtering unit that removes the hot oil directly from the fryer, filters the oil and holds it safely.

Automated and semi-automated filtering

Automated filtering systems

An automated system consists of an inbuilt oil filtration system. The oil is drained into an enclosed reservoir and an electric pump circulates it through a filter system and internal pipework back into the fryer.

Since this process is enclosed within the equipment, the operator does not come into contact with hot oil, greatly reducing any risk.

Portable oil filtering units (semi-automated)

These units are not part of the fryer, but sit alongside it. The operator attaches an extension pipe to the fryer and the hot oil is drained into an **enclosed** container within the portable unit. The oil is then filtered and returned to the fryer.

If you have a fryer with automated oil draining system or a portable oil filtering unit, refer to the manufacturer's guidelines for draining/filtering temperatures and safe operational requirements.

These, together with your own risk assessment, will determine the need for suitable protective equipment.

If there is still a risk from contact with hot surfaces or oil splashing, you may need to provide staff with eye protection, a protective apron and/or heat-resistant gloves/gauntlets.

Manual oil filtering

This involves the operator draining the oil from the fryer through a filter into a suitable metal-holding or heat-resistant hard, plastic container and manually lifting it back into the fryer (fryer oil is often supplied in hard, plastic, rigid containers). Serious accidents have occurred where oil that has not sufficiently cooled has been drained back into an empty plastic container and the base of the container has given way.

To drain oil safely and in the correct sequence, follow these guidelines:

■ ■ Turn off the appliance and the power supply at the wall socket for electric appliances, and the on/off control for gas appliances.

■ ■ Allow the oil to cool, ideally for at least six hours, and check the temperature using a suitable probe thermometer before draining. Do not drain if the temperature is above 40 °C.

■ ■ Follow the manufacturer's instructions and use the correct equipment (eg a detachable spout for the type of fryer you are emptying), making sure to bring any equipment you need to the fryer before you start.

■ ■ Depending on the type of fryer, drain the oil by drain valve, removable spout, lifting container or by tilting.

■ ■ If the oil is too cold to drain easily, reheat it briefly and agitate with the fryer basket for no more than one minute. Switch the appliance off and check the temperature again before emptying.

■ ■ Using a filter, run the oil into a suitable metal holding or heat-resistant hard, plastic container.

These containers will generally need carrying handles and a cover or lid. Before moving, make sure that the lid or cover is secure.

■ ■ Make sure the container is empty and big enough to take the volume of oil being drained at any time.

■ ■ When you are draining large volumes of oil it is safer to drain off in smaller amounts. This avoids overfilling the container and will reduce the chance of spillages when you move it. Smaller amounts will also be easier to carry.

■ ■ Place the container in a safe place where it cannot be contaminated with chemicals, water or foreign bodies. Place the container on top of a drip tray to avoid any floor contamination.

■ ■ Do not dispose of waste oil down the drain – disposal must comply with environmental legislation.

■ ■ Clean up any spillages **immediately**.

■ ■ Make sure floor areas around equipment are completely clean and dry to avoid slip risks (see also *Preventing slips and trips in kitchens and food service*).

Other precautions

Make sure the design of the drain-off tap prevents it being turned on accidentally:

Health and Safety

Executive

Page 3 of 4

■ ■ Mark clearly on it that the tap should not be touched.

■ ■ Place warning signs near the tap.

■ ■ If possible, remove the tap handle when the fryer is switched on.

Cleaning procedure

This section applies to all types of fryers.

- ■ Turn off the appliance, and the power supply at the wall socket for electric appliances and the on/off control for gas appliances.
- ■ Wear suitable protective equipment, including eye protection (if appropriate).
- ■ Check that other activities will not be put at risk by the cleaning activity.
- ■ Check that the oil has been thoroughly drained and that there are no spillages that may cause slipping.
- ■ Remove loose debris from the internal surfaces.
- ■ Thoroughly wash all internal and external surfaces with suitable cleaning chemicals and check for any leaks.
- ■ For stubborn residues, fill the fryer with your recommended cleaning agents and leave or simmer according to instructions.
- ■ Do not leave the fryer unattended or allow it to boil as this may cause it to cascade liquid onto the floor, causing additional scalding and slipping hazards.
- ■ Drain the appliance and rinse thoroughly with plenty of water.
- ■ Dry all internal surfaces and make sure there is no water left in the fryer.
- ■ Check the drain valve is closed and working properly, then refill and switch on as required.
- ■ When refilling the fryer with oil, the oil container may be too large or heavy for one member of staff. Where possible, use smaller containers.
- ■ Do not overfill the fryer. Follow the manufacturer's guidelines.
- ■ Clean up any spillages **immediately**.
- ■ Make sure floor areas around the equipment are completely clean and dry to avoid slip risks.

Training

This section applies to all types of fryers.

- ■ Make sure only staff trained in the safe use of the cleaning chemicals and cleaning procedures for the fryer do this task.
- ■ Train staff in reporting procedures if they find the equipment is faulty or if they have experienced any practical difficulties with cleaning the fryer in their specific work environment.
- ■ Make staff aware of the reason for using suitable protective equipment, ie gloves, eye protection.
- ■ Complete risk assessments for hazardous chemicals and make staff aware of the correct procedures for using cleaning chemicals.
- ■ Make safety data sheets available to staff.
- ■ A short, written procedure can act as a reminder to staff for both draining and cleaning operations.

Further reading

Preventing slips and trips in kitchens and food service

Catering Information Sheet CASI6(rev2) HSE 2012

www.hse.gov.uk/pubns/cais6.htm

Safe use of cleaning substances in the hospitality industry Catering Information Sheet CAIS22(rev2)

www.hse.gov.uk/pubns/cais22.htm

HSE has produced a suite of Catering Information Sheets and other guidance for the catering and hospitality industry. These are available on the HSE website at www.hse.gov.uk/catering/index.htm

There is also helpful advice in Health and safety made simple: The basics for your business

www.hse.gov.uk/simple-health-safety

CONTENTS

Section - 1.0	Introduction
Section - 2.0	Overall Dimensions
Section - 3.0	Specifications
Section - 4.0	Safety
Section - 5.0	Installation
Section - 6.0	Cleaning Instructions
Section - 7.0	Draining cooking oil / molten fat
Section - 8.0	Operating conditions/instructions
Section - 9.0	Maintenance
Section - 10.0	Spares Information
Section - 11.0	Electrical Information
Section - 12.0	Fault Analysis Charts



IMPORTANT NOTE

Special attention should be given to the bottom of the top tank so that a layer of sediment is not allowed to build up. If the sediment does build up a fire could result as the temperature sensors will not be able to function correctly.

Do not mix different makes or types of frying oil as a reaction can result in a thick flour-like sediment forming in the lower tank which can block the filtering system.

IMPORTANT

AZTEC TRAY CRADLE

IMPORTANT

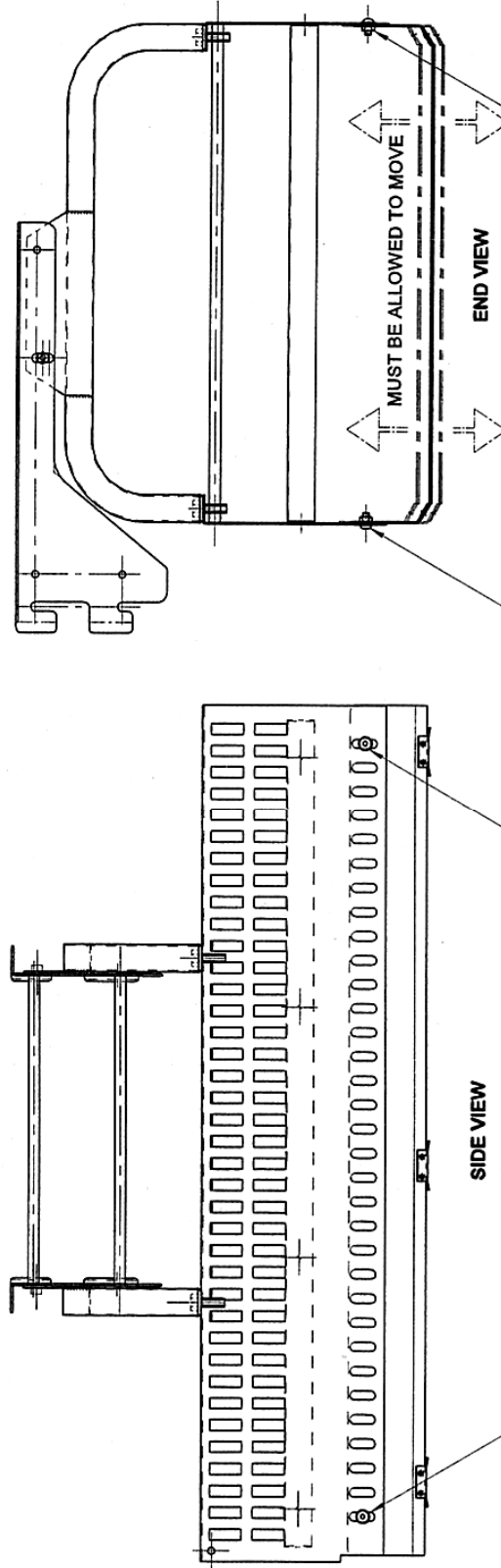

IMPORTANT

(4 POSITIONS)

M6 SCREWS AND STIFF NUTS

MUST NOT BE TIGHTENED RIGHT UP.

BOTTOM PART MUST BE ALLOWED TO MOVE UP AND DOWN

IMPORTANT

IMPORTANT

1.0 INTRODUCTION

The **MONO** fryer makes the doughnuts, you make the profits - it's as easy as that. Just set the controls, load a tray and the **MONO Aztec** takes over: Up to 900 doughnuts can be produced every hour with the minimum of supervision.

The **MONO** Fryer saves on cooking oil and electricity, as only the oil in the vicinity of the frying basket is heated to full working temperature, and is thermostatically controlled.

Oil top up and doughnut turning are fully automatic.

2.0 DIMENSIONS

Height:	Frying unit in raised position	1400mm (55")
Width:	Left hand fitted draining board	1905mm (75")
Depth:		900mm (35 1/2")

3.0 SPECIFICATIONS

Power: 12.5 kW; three phase & Neutral



The supply to this machine must be protected by a **30mA RCD**

Output: Float frying - up to 900 doughnuts per hour.

Capacity: 45 doughnuts per tray.

Frying tank capacity: 80 Ltrs (21 gallons).

100 Ltrs Total

Top up tank to level mark: 20 Ltrs (5.25 gallons)

Frying trays: MONO 762mm x 457mm (30"x18")

Weight: 160kg (353lb).

Noise level: Less than 85dB.

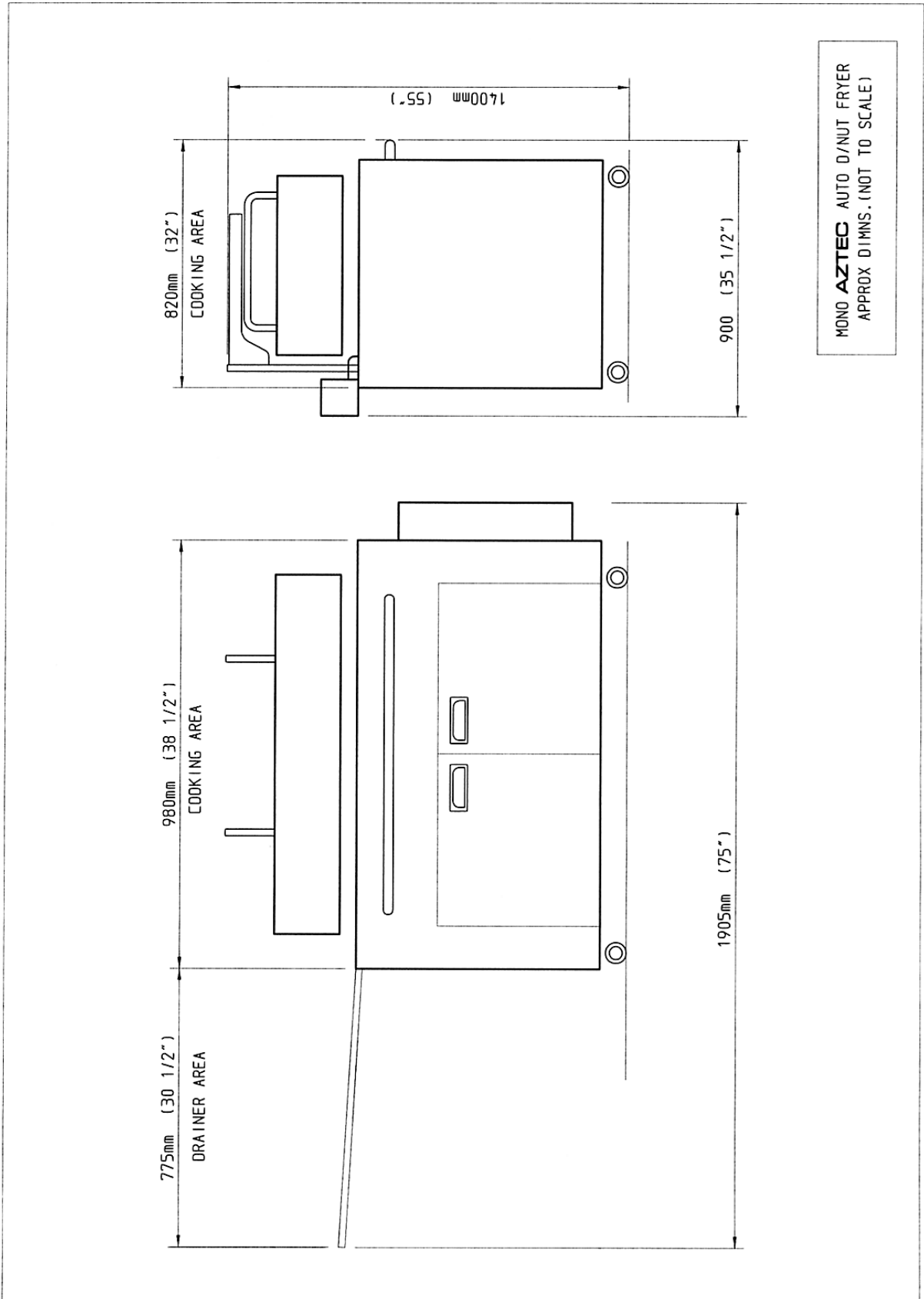

4.0 SAFETY



EXCEPT FOR OIL FILTERING ALL CLEANING AND MAINTENANCE OPERATIONS MUST BE MADE WITH FRYER DISCONNECTED FROM THE POWER SUPPLY

- 1 **Never use the fryer in a faulty condition** and always report any damage.
- 2 **No-one under the age of 16 may operate** this machine.
- 3 **No-one under the age of 18 may clean** this machine under any circumstances.
- 4 **Only trained personnel may remove any part** from this fryer that requires a tool to do so.
- 5 **Always ensure hands are dry** before touching any electrical appliance (including cable, switch and plug).
- 6 **All operatives must be fully trained.**
- 7 People undergoing training on the machine must be under direct supervision.
- 8 **Do not operate the machine with any panels removed.**
- 9 **All guards must be fixed in place** with bolts or screws unless protected by a safety switch.
- 10 **No loose clothing or jewellery** to be worn while operating the fryer.
- 11 Switch off power at the mains isolator when fryer is not in use and before carrying out any cleaning or maintenance.
- 12 **The Bakery Manager or the Bakery Supervisor must carry out daily safety checks on the fryer.**
- 13 Please read the H.S.E. information sheet contained in this manual. (see page 4)



Special attention should be given to the bottom of the top tank so that a layer of sediment is not allowed to build up. If the sediment does build up a fire could result as the temperature sensors will not be able to function correctly.

5.0 INSTALLATION

- 1 It is recommended that the Aztec Doughnut Fryer should be sited away from any main thoroughfare and that the surrounding floor area should be covered with an appropriate brand of non-slip surfacing.
- 2 **Ventilation** should be provided with an extraction canopy to ensure that convected heat and cooking smells are removed from the building. The canopy should extend a minimum of 300mm (12") beyond each edge of the fryer and have its lowest point between 1980mm (70") and 2740mm (108") above the floor. The extraction canopy should be fitted with a grease trap.
- 3 Fittings are provided for the attachment of the draining board.
- 4 The fryer should be connected to a 25 Amp 3 phase plus neutral isolator at 25 Amp with a BS 88 fuse.



The supply to this machine must be protected by a **30mA RCD**

Aztec doughnut fryers are dispatched with carrier (1) in the mid way position to avoid damage during the following check procedure:

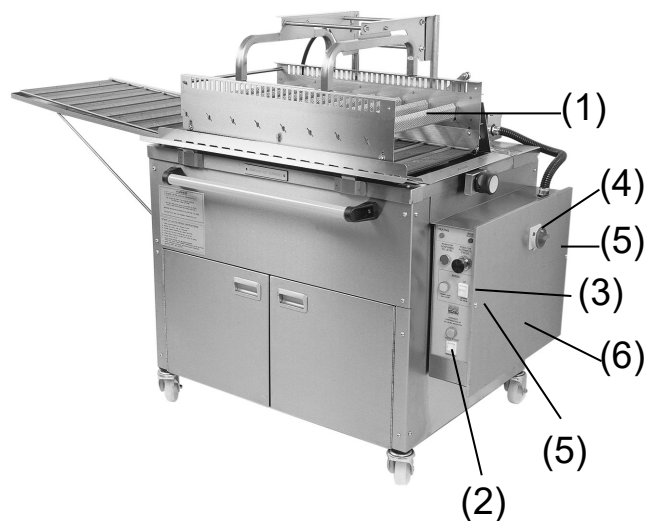

- 5
 - a. Set toggle switch (2) to "AUTO" position.
 - b. Set toggle switch (3) to "UP/OFF" position.
 - c. Turn main power switch to "ON" (vertical position)
 - d. Briefly switch toggle switch (3) to "ON/DOWN" position, then back again.

If carrier moves UP, this is CORRECT.

If carrier moves DOWN, this is NOT CORRECT. Proceed as follows:-

Transpose any two of the phase carrying wires at main isolator feeding the fryer.

6 FILLING WITH FRYING OIL.

Fill tank with cooking oil until oil is flowing into the bottom tank via the overflow slot at the back of the main tank. Allow flow to stop then pull out lower tank.

**Fill bottom tank with oil to level with bottom of the filter bag.
Do not overfill or spillage will occur during filtering.**

Do not mix different makes or types of frying oil as a reaction can result in a thick flour-like sediment forming in the lower tank which can block the filtering system.

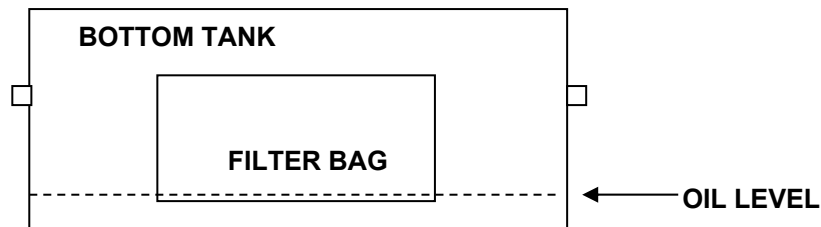

- 7 Turn main power switch (4) to 'OFF' (horizontal position).
- 8 Remove two screws (5).
- 9 Remove cover (6).
- 10 Switch breakers (top right in control box) to on position.
(or insert fuses (7) if older model)

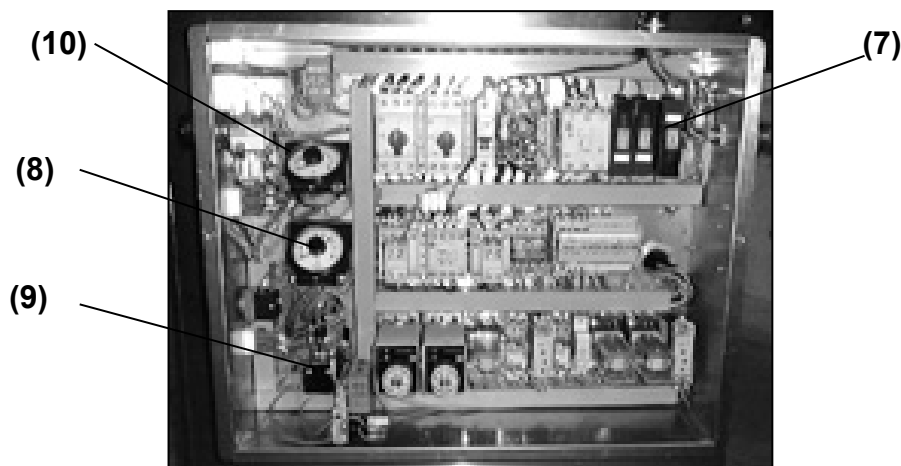

NOTE: WHILST COVER (6) IS OFF, CHECK THAT THE THREE THERMOSTATS ARE SET CORRECTLY.

FRYING THERMOSTAT (8) SHOULD BE SET FOR 190 °C.

SAFETY OVER-RIDE THERMOSTAT (9) MUST BE SET AT 210 °C MAXIMUM.

FIRST STAGE HEATING THERMOSTAT (10) SHOULD BE SET AT 90 °C .

- 11 Replace cover (6) and screws (5)
- 12 Switch on main control switch (4)

TO ADJUST COOKING TIMERS

- 1 Turn main isolator off.
- 2 Turn power off.
- 3 Remove cover screws x2
- 4 Remove cover.
- 5 Adjust timers A and B.
(A) left hand = 1st side cooking
(B) right hand = 2nd side cooking
- 6 Replace cover.
- 7 Replace screws x 2
- 8 Turn power on.
- 9 Turn main isolator on. (Buzzer will sound)
- 10 Push “**confirm oil level**” button. (make sure there is oil in the top tank first)
- 11 Buzzer will stop.
If temperature is above 90 °C oil will start to heat.
If temperature is below 90 °C filtering cycle will have to take place.
i.e. open and close drain tap and allow pump to operate for 18 mins.
Then press “oil confirm button” to stop buzzer and begin heating to cooking temperature.



(A) (B)

ISOLATION

**TO STOP THE DOUGHNUT FRYER IN AN
EMERGENCY
SWITCH OFF THE MAINS WALL ISOLATOR.**

6.0 CLEANING INSTRUCTIONS

WARNING:
ISOLATE FROM MAINS SUPPLY BEFORE CLEANING AND ALLOW TO COOL.



HOT OIL IS DANGEROUS

DAILY

Wipe down exterior bodywork with a damp cloth and cleaning fluid.

AS NEEDED (at least weekly)

TO CLEAN OIL FILTER





ALLOW OIL TO COOL BEFORE ATTEMPTING TO REMOVE FILTER

- 1 Open front doors.
- 2 Pull lower tank towards you.
- 3 Lift Filter bag and frame out of tank.
- 4 Unclip poppers around top edge and remove filter.
- 5 **Only use hot water to clean filter. Do not use soap or detergent. Do not clean in a dishwasher.**
- 6 Ensure filter is dry and replace on to filter frame ensuring all poppers are fastened.
- 7 Insert filter assembly into lower tank and push back under machine. Close doors.



REMOVAL OF TURNOVER DEVICE AND SEPARATOR UNIT FOR CLEANING

Before proceeding with the following, the fryer must be allowed to cool and oil drained

- 1  Lift turnover device off rear bars as shown in photo. (**CAUTION UNIT IS HEAVY**).
- 2 Turn separator unit adjuster to position 1.
- 3  Lift separator unit carefully and remove from tank. (**CAUTION UNIT IS HEAVY**).
- 4 After cleaning replace all parts in reverse order. Pay particular attention to the separator unit engagement with its adjuster.

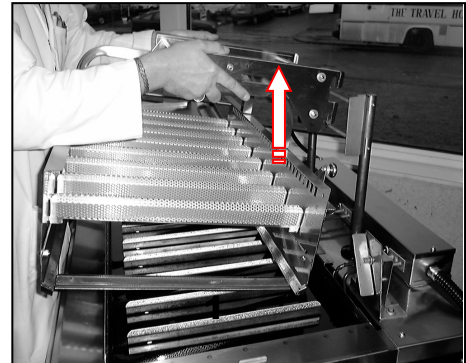

POSITION 1



NOTE

Special attention should be given to the bottom of the top tank so that a layer of sediment is not allowed to build up. If the sediment does build up, a fire could result as the temperature sensors will not be able to function correctly.

7.0 DRAINING COOKING OIL



WARNING: HOT OIL IS DANGEROUS (ALLOW TO COOL BEFORE DRAINING).

- 1 Remove drain tap cover plate on rear panel (6 screws)
- 2 Place hose in suitable container.
- 3 Turn mains power on (buzzer sounds).
- 4 Press oil level confirmation button.
- 5 If oil is not warm, allow to heat until buzzer sounds.
- 6 Open drain tap above lower drain tank (pump will start).
- 7 Place hose in container and open rear drain tap.
- 8 Fill containers to a safe level using rear tap as on/off control.
- 9 When fryer is empty, turn off power and close both drain taps
- 10 Replace drain tap cover plate.

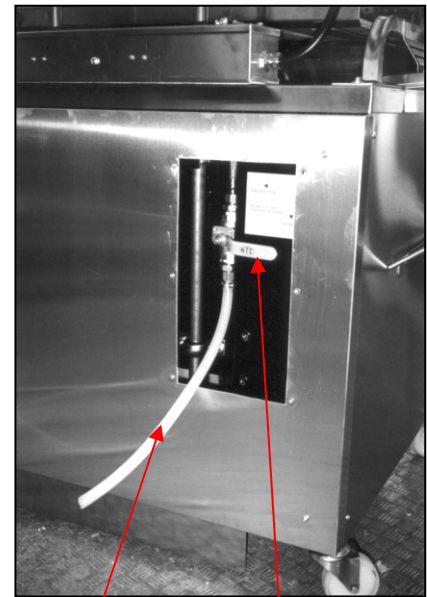

HOSE

DRAIN TAP

8.0 OPERATING INSTRUCTIONS

START UP AND FILTERING

CAUTION!!

ELEMENT HEATING WILL STOP WHILE PUMP IS IN OPERATION. ENSURE OIL IS IN TOP TANK AT ALL OTHER TIMES. I.E WHEN TURNING MAIN POWER ON.

ALLOW OIL TO COOL BELOW COOKING TEMPERATURE BEFORE FILTERING

From cold. (if warm go to 5)

- 1 Turn main power on . (buzzer sounds).
- 2 Check oil level in both tanks. (top up if required).
- 3 Press green “confirm oil level” button (1).
- 4 Allow oil to heat. (buzzer will sound when ready).

From warm

- 5 Ensure lower tank is pushed right in. Open drain valve (3) and allow top tank to drain.
- 6 Close drain valve.
- 7 When pump stops and buzzer sounds, check oil level then press, “confirm oil level” button. (1)
- 8 When correct cooking temperature is reached heating light (2) will go off.

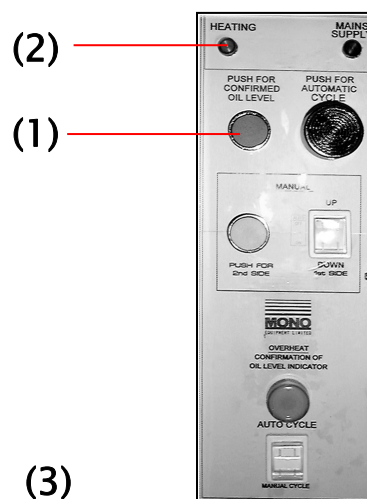

DO NOT.....

DO NOT TURN POWER OFF WHILST PUMP IS OPERATING .DO NOT LEAVE MACHINE WITH ALL THE OIL IN THE BOTTOM TANK, (ALWAYS PUMP BACK TO TOP TANK BEFORE LEAVING MACHINE.)

MACHINE CONTROLS

- 1 When toggle switch (2) is in the 'AUTO' position and toggle switch (3) is set to 'ON', depressing control button (15) starts the frying sequence:

***Down (1st side fry)
Turnover (2nd side fry)
Raise (drain)***

- 2 When toggle switch (2) is in the 'MANUAL' position, toggle switch (3) controls the up and down movement of the carrier for the 1st side and push button (16) turns doughnuts and then raises the carrier.

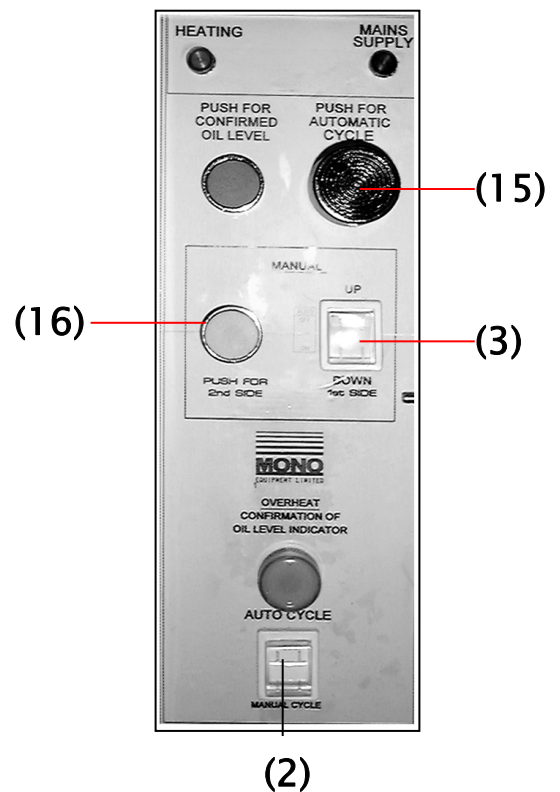

MACHINE OPERATION

- 1 Turn main control switch (4) vertically to 'ON' position. Carry out start up and filtering sequence. (page 18)
- 2 Set toggle switch (2) to 'AUTO'.
- 3 Set toggle switch (3) to 'ON'.
- 4 Slide tray into basket. **Ensure that the tray is pushed up against the cradle end stops or the machine will jam.**
- 5 Press control button (15) to start frying sequence.

NOTE

IF A TRAY IS NOT PLACED IN THE CORRECT POSITION, AS SHOWN DURING TRAINING, THE CARRIER MAY JAM IN POSITION.

IN AN EMERGENCY, TOGGLE SWITCH (3) MAY BE SWITCHED TO 'OFF' TO HALT CARRIER TRAVEL IRRESPECTIVE OF POSITION.

ADJUSTMENT OF TURNOVER DEVICE

Depending on the size or shape of the doughnut being fried the separator unit must be adjusted.

- 1** Turn Knob **(1)** on right hand side of tank, clockwise or anticlockwise.
- 2** Read off scale **(2)** on left until required position is found.
- 3** The positions required will have to be determined and recorded for future reference.
- 4** Generally position **(1)** is for large products and position **(4)** is for very small or finger doughnuts.

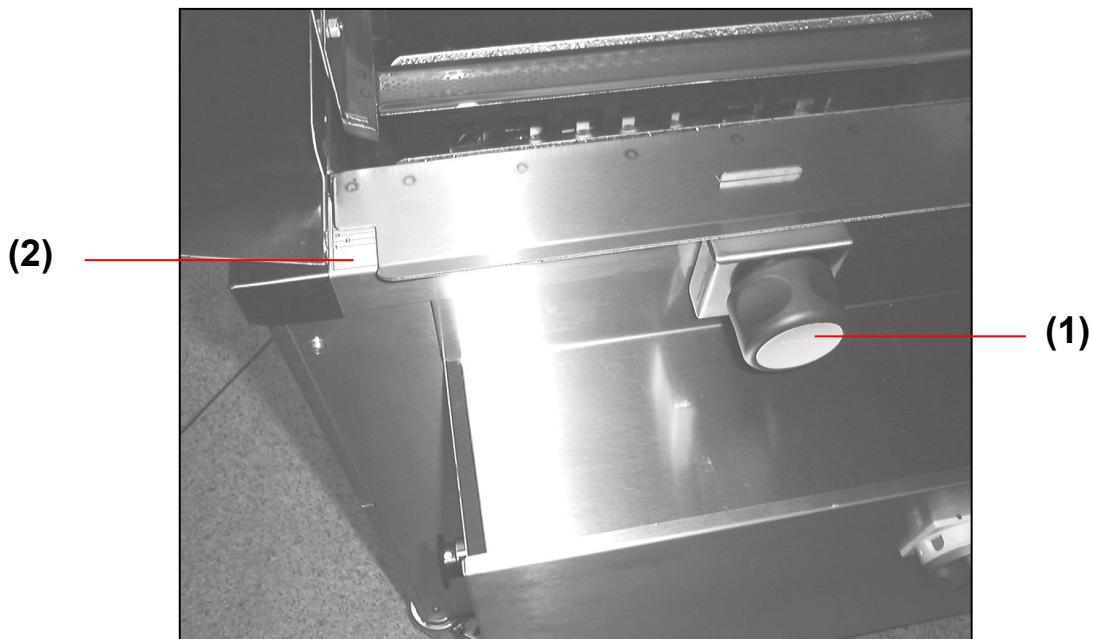

9.0 MAINTENANCE



WARNING

- This appliance must be maintained at regular intervals. The frequency of maintenance will depend upon your specific use and location. The maximum service interval should be 12 months.
 - Service and maintenance should only be undertaken by suitably qualified, trained, and competent engineers.
 - You must immediately report any damage or defect arising with the appliance.
 - Unsafe equipment is dangerous. Do not use the appliance. Isolate the power supply and contact MONO or your appointed service agent.
-

- 1 The fryer must not be used if bare cables are visible
- 2 Follow cleaning instructions meticulously.

Twice A Year.

- 1 Isolate machine from mains supply.
- 2 Remove back sheet and grease drive shaft (20) and guide shafts (21) with high temperature grease.

(20)

(21)

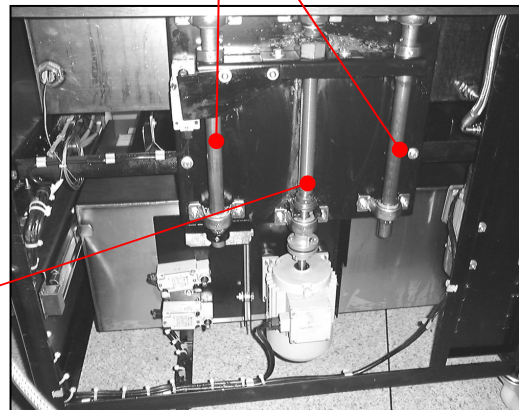

IMPORTANT NOTE

Special attention should be given to the bottom of the top tank so that a layer of sediment is not allowed to build up. If the sediment does build up a fire could result as the temperature sensors will not be able to function correctly.

Do not mix different makes or types of frying oil as a reaction can result in a thick flour-like sediment forming in the lower tank which can block the filtering system.

SERVICE AND SPARES

If a fault arises, please do not hesitate to contact the Customer Service Department, quoting the **machine serial number** on the silver information plate of the machine and on the front cover of this manual



Queensway
Swansea West Industrial Estate
Swansea,
SA5 4EB, UK

email: spares@monoequip.com
www.monoequip.com
Tel. +44/0 1792 561234

Spares Tel. +44/0 1792 564039



10.0 SPARES

IF IN ANY DOUBT - ASK

ELECTRICAL

PT-Ref	DESCRIPTION	PART No.
PT-2a	UP/DOWN MOTOR MANUAL MOTOR STARTER	B801-03-020
PT-5a	MAIN MOTOR UP CONTACTOR	B801-08-033
PT-9	HEATER CONTACTOR	B801-08-034
PT-10a	FIRST IMMERSION TIME TIMER	B819-34-019
PT-15	FILTER PUMP RUN ON TIMER	B842-34-003
PT-16	180 °C COOKING TEMPERATURE THERMOSTAT	B873-30-002
PT-17	OVERHEAT THERMOSTAT	B873-30-001
PT-18a	HEATING ELEMENT FUSE CARRIER	B823-39-001
PT-20b	HEATING ELEMENT FUSE	B842-85-005
PT-18	HEATING ELEMENT MCB	B872-22-008
PT-19	HEATING ELEMENT MCB	B872-22-008
PT-20	HEATING ELEMENT MCB	B872-22-008
PT-21	BUZZER	B883-92-001
PT-22	SUPPLY ON INDICATOR LIGHT	B842-43-001
PT-23	HEATERS ON INDICATOR LIGHT	B842-43-002
PT-24	START AUTO CYCLE PUSH BUTTON	B808-12-001
PT-24a	AUTO CYCLE PUSH BUTTON	B801-12-039
PT-24b	AUTO CYCLE PUSH BUTTON BLOCK	B801-14-002
PT-24c	AUTO CYCLE PUSH BUTTON ADAPTOR	B801-18-003
PT-25a	CONFIRMATION OIL LEVEL PUSHBUTTON (GREEN)	B801-12-029
PT-25b	PUSHBUTTON CONTACT BLOCK	B801-14-001
PT-26	ON/OFF-UP/DOWN ROCKER SWITCH	B900-07-006
PT-27a	MANUAL-START SECOND IMMERSION TIME PUSHBUTTON (YELLOW)	B801-12-030
PT-29	SET FIRST IMMERSION TIME POTENTIOMETER	B842-59-030
PT-34	MANUAL VALVE SWITCH 'A'	B842-07-020
PT-42a	MID WAY LIMIT SWITCH BODY	B801-11-013
PT-42b	MID WAY LIMIT SWITCH ACTUATOR	B801-45-005
PT-45	KILLER OVERHEAT THERMOSTAT N°1	B873-30-005
* PT-51	HEATING ELEMENTS -240V (4.15V 3PH+N)	B906-04-001
* PT-51	HEATING ELEMENTS -220V (380V 3PH+N)	B906-04-005
PT-53a	HEATING ON/OFF LATCHING RELAY	B842-36-001
PT-59	OIL CYCLE TOP UP TIMER	B992-34-001
PT-60	INDUCTIVE SENSOR	B801-99-006

UP TO SEPT 03

MECHANICAL

DESCRIPTION	PART No.
FAT FILTER BAG	A900-30-018
SCREEN TOOL	029-12-01600
ACTUATOR ROLLER	A900-20-038
NUT (turnover device)	029-18-03700
PLASTIC/OILITE BUSH (cradle lift)	P700-05-021
PLASTIC/OILITE BUSH (cradle lift)	P700-05-022
RETURN SPRING (turnover device)	A900-19-058

B	JC	25-06-07	SEE ECN 3011. PTZA; 5A & 9 WERE B859 PARTS. NO LONGER AVAILABLE
A	RAC	25-09-03	SEE ECN 'S 1948/1949
 SWANSEA IND EST. FFOREESTFACH, SWANSEA, W. WALES TEL: (01792) 561234 EQUIPMENT LIMITED FAX: (01792) 561016 Email: 100432.505@compuserve.com			
ELECTRICAL SPECIFICATIONS:-		TITLE:	
380V/415V 3PH+N 50HZ		AZTEC DOUGHNUT FRYER	
4 WIRE		ELECTRICAL AND MECHANICAL	
DRAWN: RAC		SPARE PARTS LIST	
DATE: 20-6-00		ELECTRICALLY APPROVED BY:-	
DRAWING NO. M029E25-SPARES		P. BOYLES	
REV: B			

COPYRIGHT © 1998 - THIS DESIGN/DRAWING IS THE PROPERTY OF MONO EQUIPMENT LTD. AND MUST NOT BE REPRODUCED, COPIED, NOR ITS CONTENTS DIVULGED WITHOUT PRIOR WRITTEN PERMISSION.

ALL DIMENSIONS IN mm UNLESS OTHERWISE STATED

DO NOT SCALE - IF IN DOUBT ASK

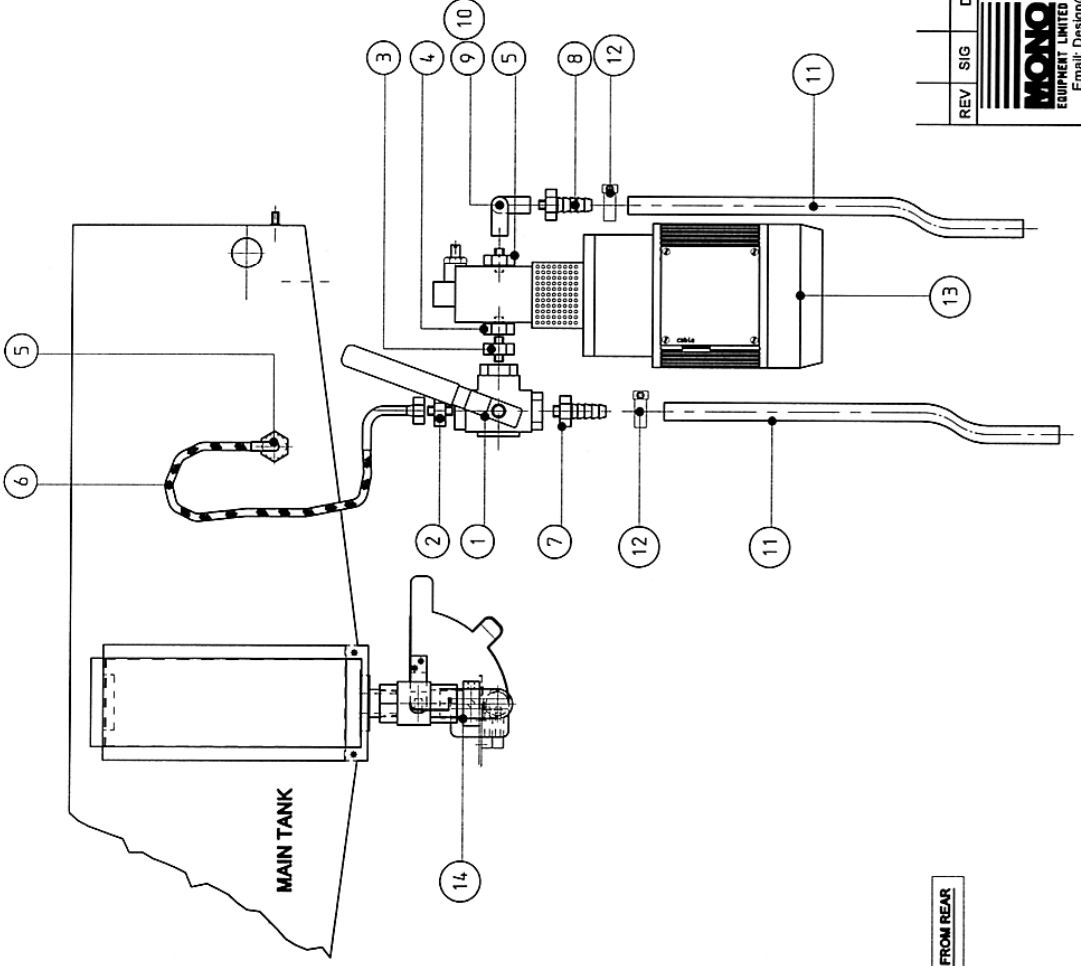

ITEM	PART No.	DESCRIPTION	QTY
1	A900-34-195	"L" PORT BALL VALVE	1
2	A900-34-248	1/2" BSPT MALE X 3/8" BSP MALE	2
3	A900-34-247	1/2" BSPT MALE X 1/4" BSP MALE	1
4	A900-34-246	1/4" BSP MALE X 1/4" BSP FEMALE SWIVEL	1
5	A900-23-030	3/8" BSP X 1/4" BSP ADAPTOR	2
6	A900-34-249	3/8" CONVOLUTED HOSE/90° BSP FEMALE ENDS	1
7	A900-34-251	3/8" BSP BARB FITTING / 1/2" BSPT	1
8	A900-34-250	3/8" BSP BARB FITTING / 3/8" BSPT	1
9	A900-23-031	ELBOW 3/8" BSP X 3/8" BSP FEMALE/FEMALE	1
10	A900-34-252	3/8" BSP MALE/MALE ADAPTOR 450mm LG	1
11	A900-23-026	SILICONE HOSE 3/8" ID X 3/4" OD X 450mm LG	2
12	A900-01-096	JUBILEE CLIP - SIZE 0	2
13	B754-74-002	PUMP/MOTOR	1
14	M029-14-00000	DRAIN TAP ASSY	1

VIEW FROM REAR

REV	SIG	DATE	REVISION	ECN NO.
<p>SWANSEA IND EST. FFORESTFACH, SWANSEA, SAS 4EB. TEL: (01792) 561234 EQUIPMENT LIMITED FAX: (01792) 561016 Email: Design@monoequip.com</p>				
<p>TITLE: OIL CIRCULATION SYSTEM (REAR OUTLET - ENCLOSED TAP)</p>			<p>WORKS ORDER NO.</p>	
<p>MAT'L: AS ABOVE</p>			<p>DRAWN: RAC DATE: 24-3-00</p>	
<p>MAT'L QTY: ---</p>			<p>PURCHASE ORDER NO.</p>	
<p>NO. REQ: 1 SET</p>			<p>SCALE: M029-12-02500</p>	
<p>FINISH: AS SUPPLIED</p>			<p>DRAWING NO. ---</p>	
<p>1st ANGLE</p>			<p>REV: ---</p>	

REMOVE ALL BURRS & SHARP EDGES - ON SHEET METAL PARTS EXTERNAL CORNERS TO BE SAFETY RADIUSED 2mm UNLESS STATED OTHERWISE
 SURFACE FINISH: $\frac{1}{2}$ COARSE FINISH, $\frac{1}{4}$ MEDIUM FINISH, $\frac{1}{8}$ FINE FINISH, $\frac{1}{16}$ GROUND FINISH
 OPEN TOL. 150 & BELOW $\pm .5$, OVER 150 ± 1.0 DECIMAL DIMS. 75 & BELOW $\pm .25$, 75 TO 300 $\pm .4$, 300 TO 600 ± 1.0
 COPYRIGHT © 1998 - THIS DESIGN/DRAWING IS THE PROPERTY OF MONO EQUIPMENT LTD. AND MUST NOT BE REPRODUCED, COPIED, OR 1st ANGLE
 NOR ITS CONTENTS DIVULGED WITHOUT PRIOR WRITTEN PERMISSION.



11.0 ELECTRICS

IF IN ANY DOUBT - ASK

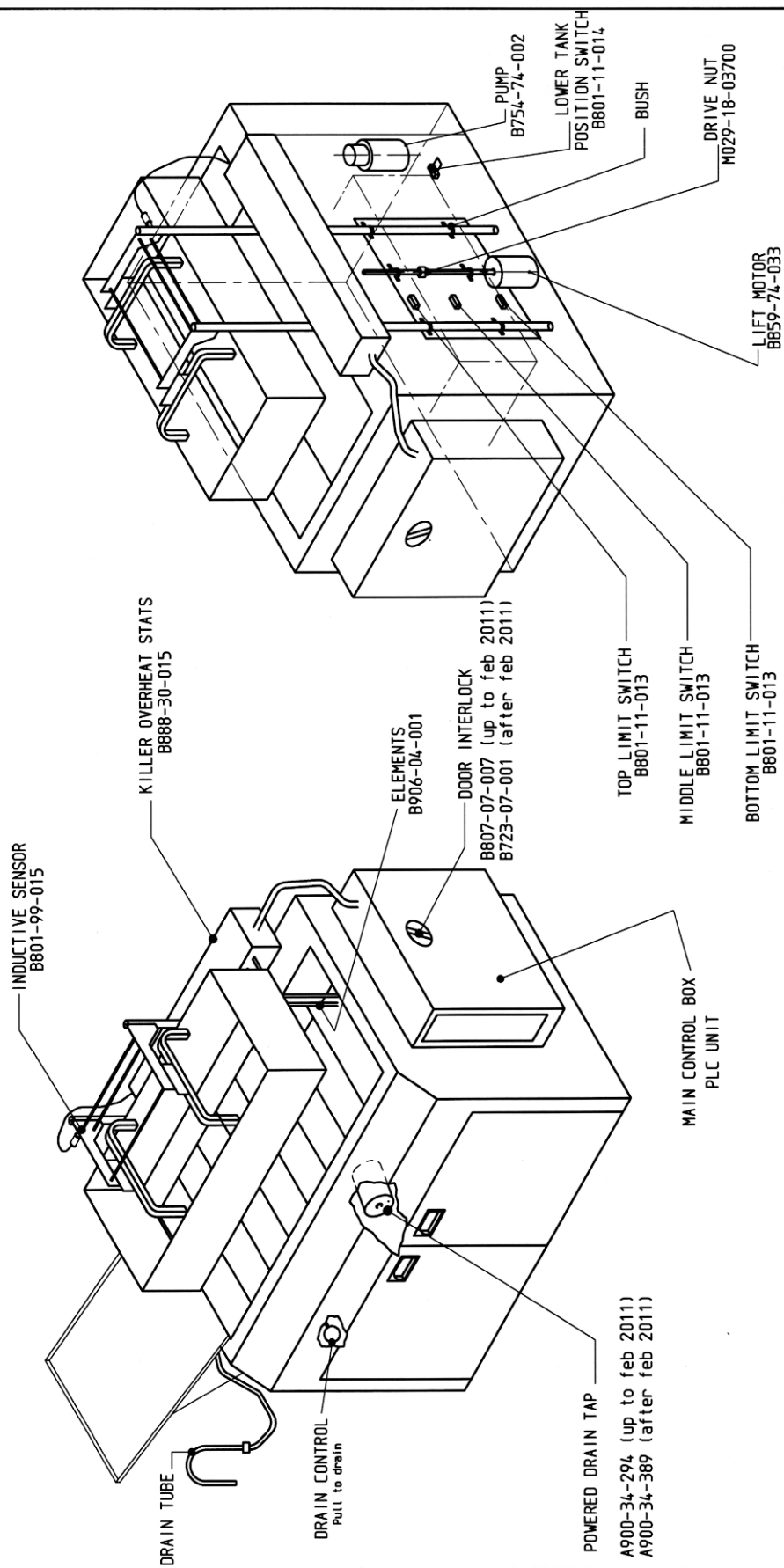

REV	SIG	DATE	REVISION	EGR NO.
A	RAC	30-01-12	Motor B859-74-033 was 009	DN-001-12
<p>  QUEENSWAY SWANSEA WEST IND PARK SWANSEA, SA5 4EB. TEL: (01792) 561234 FAX: (01792) 561016 </p>				
<p> TITLE: AZTEC DOUGHNUT FRYER COMPONENT LAYOUT (PLC VERSION) </p>			<p> ELECTRICALLY APPROVED BY:- DRAWN: RAC </p>	
<p> ELECTRICAL SPECIFICATIONS:- </p>			<p> DATE: 15-3-02 DRAWING NO.: M029-25-35400 REV: A </p>	

COPYRIGHT © 1998 - THIS DESIGN/DRAWING IS THE PROPERTY OF MOND EQUIPMENT LTD. AND MUST NOT BE REPRODUCED, COPIED, NOR ITS CONTENTS DIVULGED WITHOUT PRIOR WRITTEN PERMISSION.

IF IN ANY DOUBT - ASK

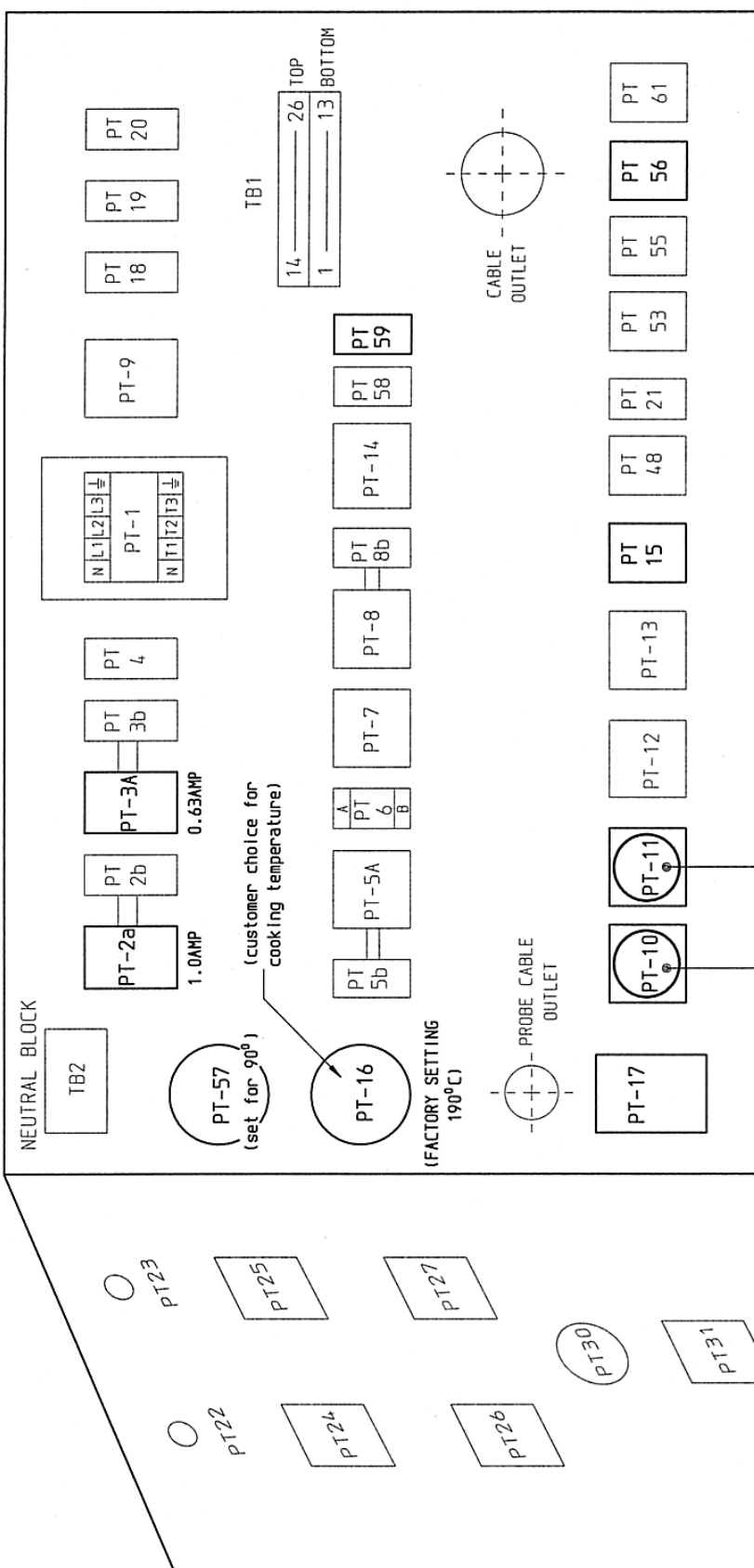

1st position timer 2nd position timer
set for customer cooking requirements
 (FACTORY SETTING 1 MINUTE EACH)

REV	SIG	DATE	REVISION	ECON NO.
<p>MONO EQUIPMENT QUEENSWAY SWANSEA WEST IND PARK SWANSEA, SA4 4EB. TEL: (01792) 681234 FAX: (01792) 661016 Email: engineering@monoequip.com</p>				
<p>MONO</p>			<p>TITLE: AZTEC DOUGHNUT FRYER CONTROL BOX LAYOUT</p>	
<p>ELECTRICAL SPECIFICATIONS:- 380V/415V 3Ph+N 50HZ</p>			<p>DRAWN: JC ELECTRICALLY APPROVED BY:- P. BOYLES</p>	
			<p>DATE: 16-11-99 DRAWING NO. M029E25-35300</p>	
			<p>REV: —</p>	

COPYRIGHT © 1998 - THIS DESIGN/DRAWING IS THE PROPERTY OF MONO EQUIPMENT LTD. AND MUST NOT BE REPRODUCED, COPIED, NOR ITS CONTENTS DIVULGED WITHOUT PRIOR WRITTEN PERMISSION.

IF IN ANY DOUBT - ASK

**OIL PUMP
RUN ON TIMER**

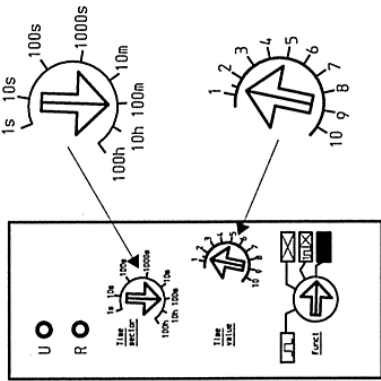

PT15

**90°C TEMPERATURE
DELAY TIMER**

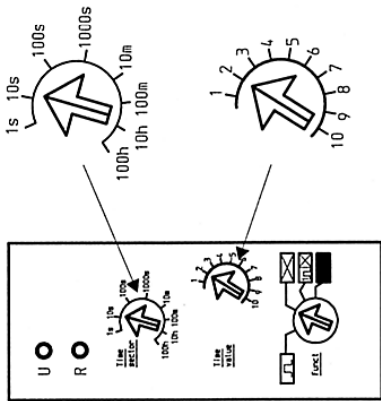

PT56

**OVERHEAT
THERMOSTAT**

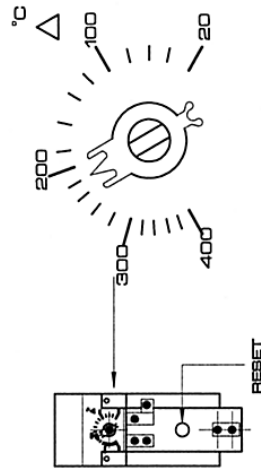

PT17

**OIL PUMP
TOP UP TIMER**

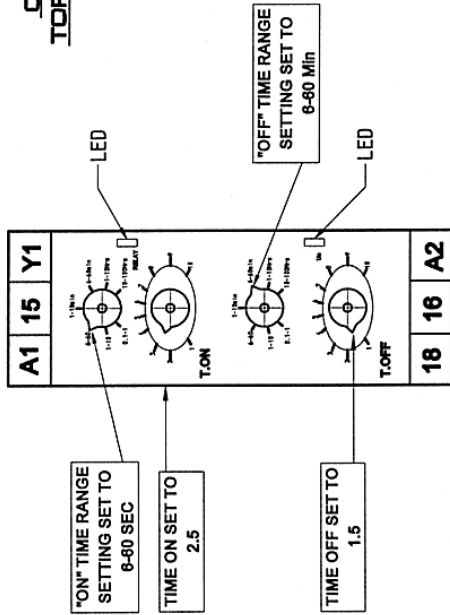

**ALTERNATIVE VERSION
TO ABOVE PT59**

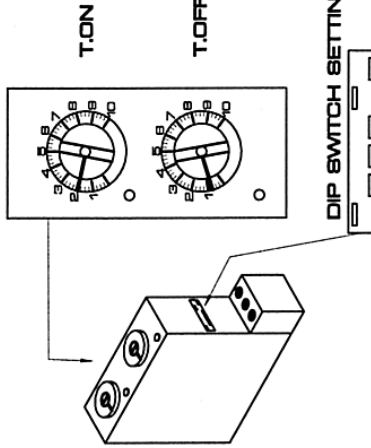

REV	SIG	DATE	REVISION	ECN NO.
			MONO EQUIPMENT QUEENSWAY SWANSEA WEST IND PARK SWANSEA SA5 4EB. TEL: (01782) 561234 FAX: (01782) 561016 Email: engineering@monoequip.com	
TITLE: AZTEC DOUGHNUT FRYER SETTING OF TIMERS OIL PUMP RUN ON TIMER, 90°C TEMPERATURE DELAY TIMER, TOP UP TIMER.				
ELECTRICAL SPECIFICATIONS:- DRAWN: RAC/JC DATE: 6-8-99				
DRAWING NO. M029E25-34800				REV: -

**PART NUMBERS REFER TO
MAIN DRAWING PT No.M028-25-36100**

COPYRIGHT © 1998 - THIS DESIGN/DRAWING IS THE PROPERTY OF MONO EQUIPMENT LTD. AND MUST NOT BE REPRODUCED. COPIED,
NOR ITS CONTENTS DIVULGED WITHOUT PRIOR WRITTEN PERMISSION.

IF IN ANY DOUBT - ASK

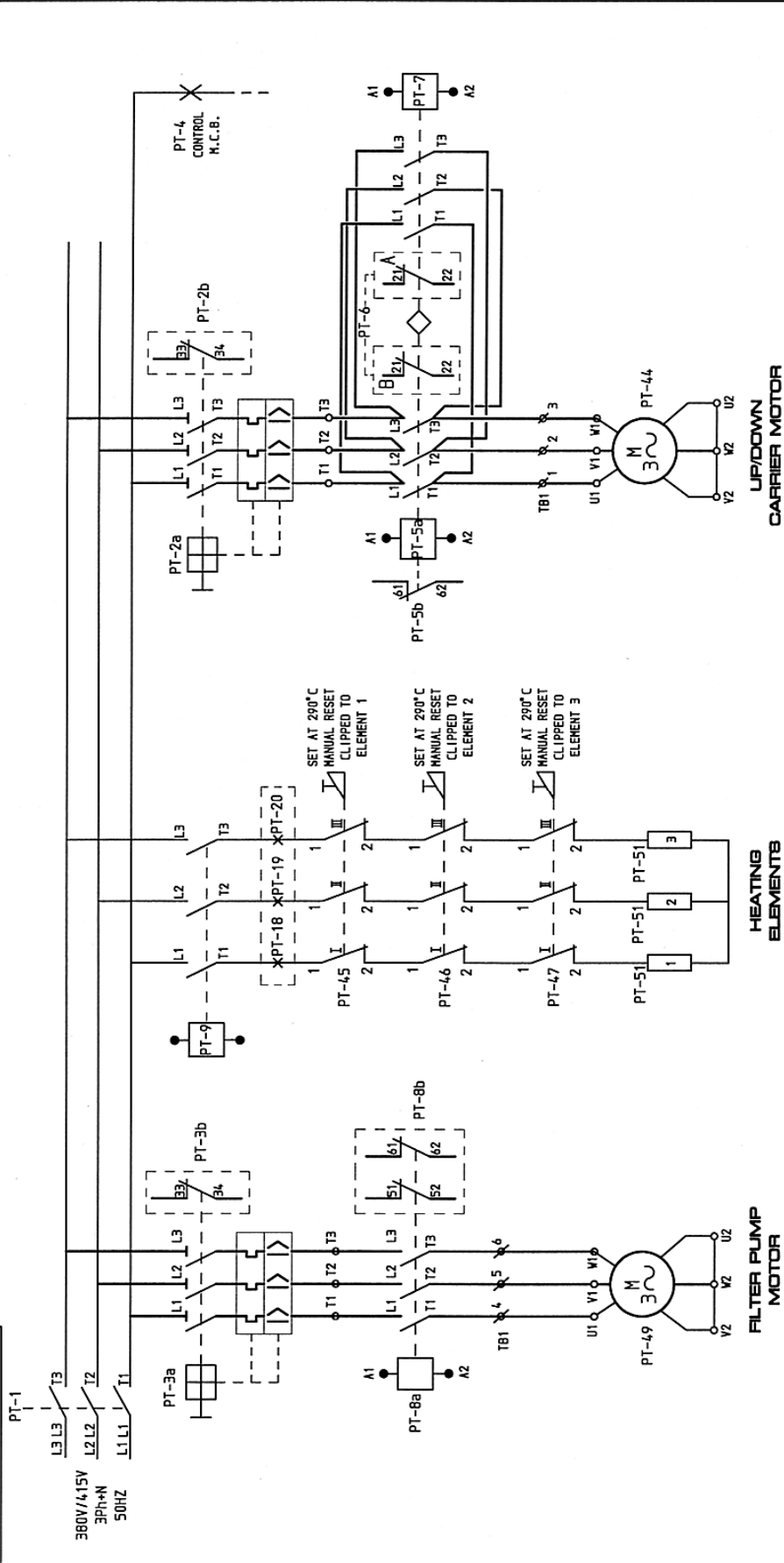

REV	SIG	DATE	REVISION	ECH NO.
<p>MONO EQUIPMENT QUEENSWAY SWANSEA WEST IND PARK SWANSEA, SA5 4EB. MONO TEL: (01782) 581234 FAX: (01782) 551016 Email: engineering@monoequip.com</p>				
ELECTRICAL SPECIFICATIONS:-			DRAWN: JC	
380V/4.15V 3Ph+N 50HZ			DATE: 27-7-99	
AZTEC DOUGHNUT FRYER POWER CIRCUIT WIRING DIAGRAM			ELECTRICALLY APPROVED BY: P. BOYLES	
			DRAWING NO. M029E25-34500	
			REV: —	

COPYRIGHT © 1998 - THIS DESIGN/DRAWING IS THE PROPERTY OF MONO EQUIPMENT LTD. AND MUST NOT BE REPRODUCED, COPIED, NOR ITS CONTENTS DIVULGED WITHOUT PRIOR WRITTEN PERMISSION.

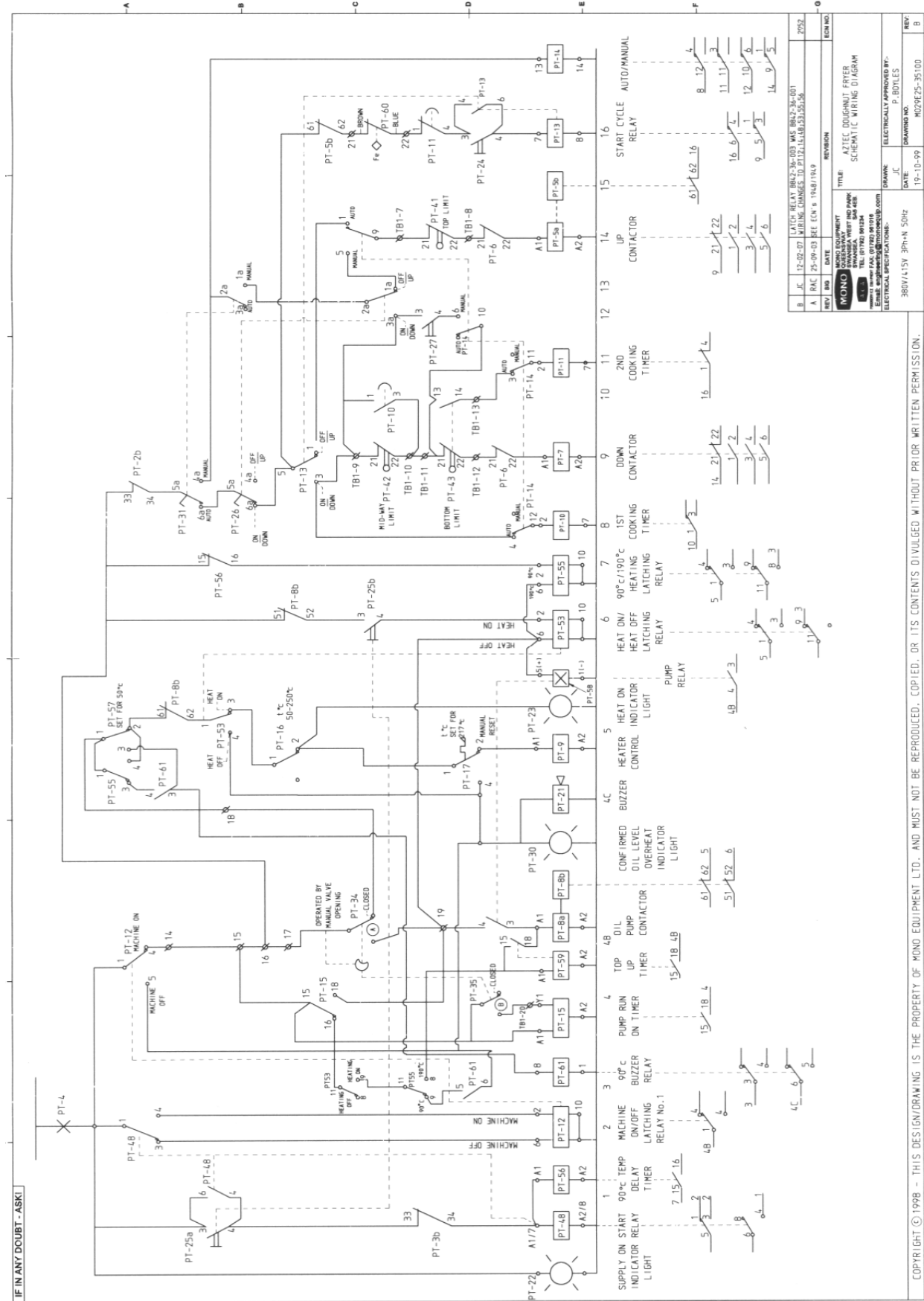

IF IN ANY DOUBT - ASK

A

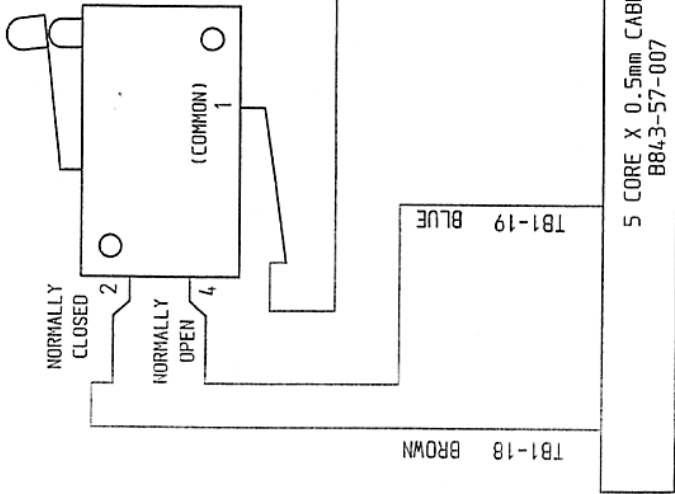

B

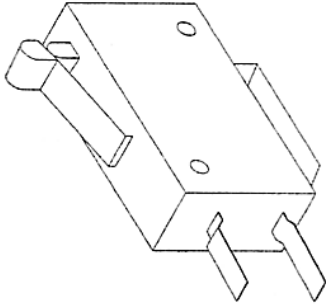
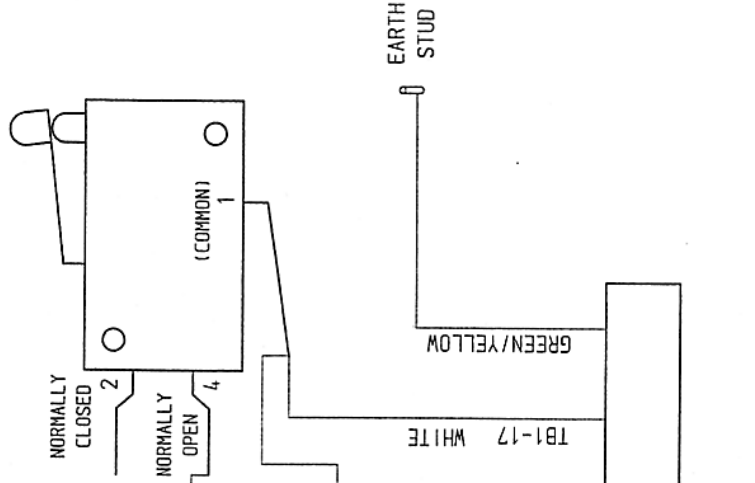

REV	SIG	DATE	REVISION	ECN NO.
<p>MONO EQUIPMENT QUEENSWAY SWANSEA WEST IND PARK SWANSEA, SA5 4EB. MONO TEL: (01782) 561234 FAX: (01782) 561016 Email: engineering@monoequip.com</p>				
ELECTRICAL SPECIFICATIONS:-			TITLE: AZTEC DOUGHNUT FRYER MANUAL VALVE MICROSWITC H WIRING	
DRAWN: JC			ELECTRICALLY APPROVED BY:- P. BOYLES	
DATE: 8-9-99			DRAWING NO. M029E25-34900	
			REV: —	

corrected to match production 10-03 RAC
 COPYRIGHT © 1998 - THIS DESIGN/DRAWING IS THE PROPERTY OF MONO EQUIPMENT LTD. AND MUST NOT BE REPRODUCED, COPIED,
 FOR ITS CONTENTS DIVULGED WITHOUT PRIOR WRITTEN PERMISSION.



12.0 FAULT FINDING

AZTEC FRYER FAULT CHECKS.

1. DONUTS NOT CORRECT COLOUR

2. NO MOVEMENT

3. OIL NOT CIRCULATING (NO FILTERING)

4. CARRIER COMES STRAIGHT BACK UP

5. DONUTS NOT TURNING

6. IF FRYER DOES NOT FUNCTION

1. DONUTS NOT CORRECT COLOUR

- Contact your company head office. No adjustments should be attempted. If a private bakery, please contact our service team for any adjustments that may be required for your products.

2. NO MOVEMENT

- The carrier assembly will not move until oil is up to frying temperature.
OR SEE SECTION 6

3. OIL NOT CIRCULATING (NO FILTERING)

- Is blue tube overhanging filter bag?
- Is white suction tube in bottom tank?



- Bottom tank filter bag not there (clogs suction tube) or very dirty (stops oil flow).
- Top tank not cleaned allowing build up around elements and clogs drain hole to tap.
- Mixing different frying oils causing reaction and sediment to form.
(Looks like flour thrown in tank)
- **DO NOT USE SOLID FAT**

4. CARRIER COMES STRAIGHT BACK UP

- Obstruction causing carrier to lift off support brackets.

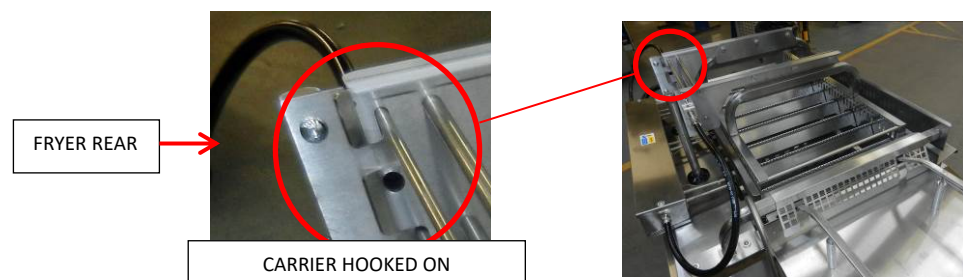

- Screws at bottom of carrier have been tightened. (Unlikely but should be loose to allow up/down movement).

5. DONUTS NOT TURNING

- Is oil at correct levels? (Check oil is to level shown on rear face of bottom tank).

- Has splitter unit been set at the correct gap for the type of donut?

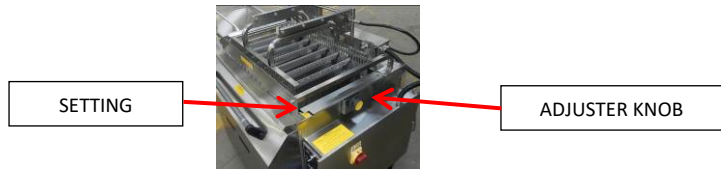

- Adjuster for donut size not working -
Check if splitter unit slot is located on adjuster tab.

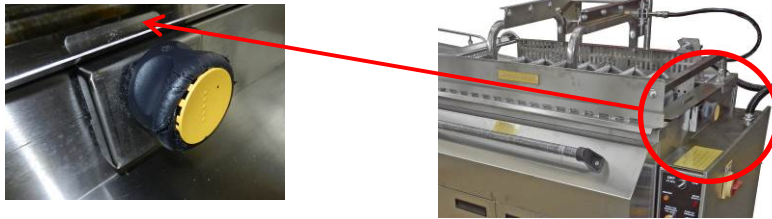

6. IF FRYER DOES NOT FUCTION



1. Mains power connected? (Check socket on wall or store isolator)

2. Is yellow/red isolator switch on side at on position?

4. Is mains light on panel "ON"? (IF NOT CHECK 1 AND 2 AGAIN)

5. Is elements heating light on panel "ON" after "PUSH TO CONFIRM OIL LEVEL" button is pressed?
(GOES OUT WHEN OIL IS UP TO CORRECT TEMPERATURE)



LIGHT FLASHING AND BUZZING SOUND

1. Continuous buzzer and light flashing.

- This is normal and is asking for "push confirm oil level" button to be pressed. Only press if there is correct amount of oil in top and bottom tank.

2. On/off buzzer and light flashing.

- Bottom tank not pushed fully back in. Open doors and push tank in.

3. Continuous buzzer and light.

- Pump overload tripped. – Call Engineer

4. Continuous light only.

- Overheat tripped - Call Engineer

HELP FOR TRAINED REPAIR ENGINEERS

AZTEC FRYER HEATING AND OIL FILTER FAULT CHART.

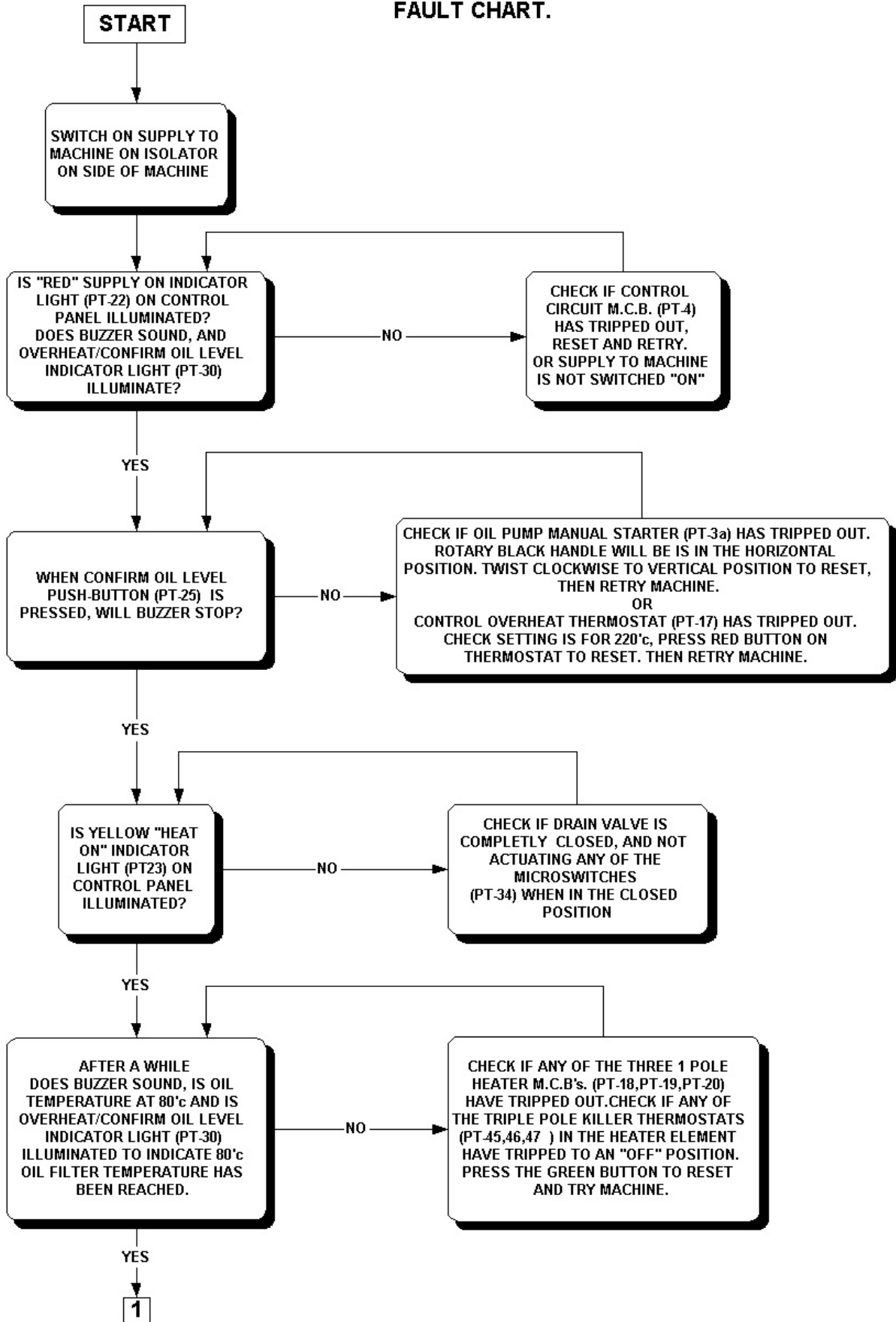

AZTEC FRYER HEATING AND OIL FILTER FAULT CHART.

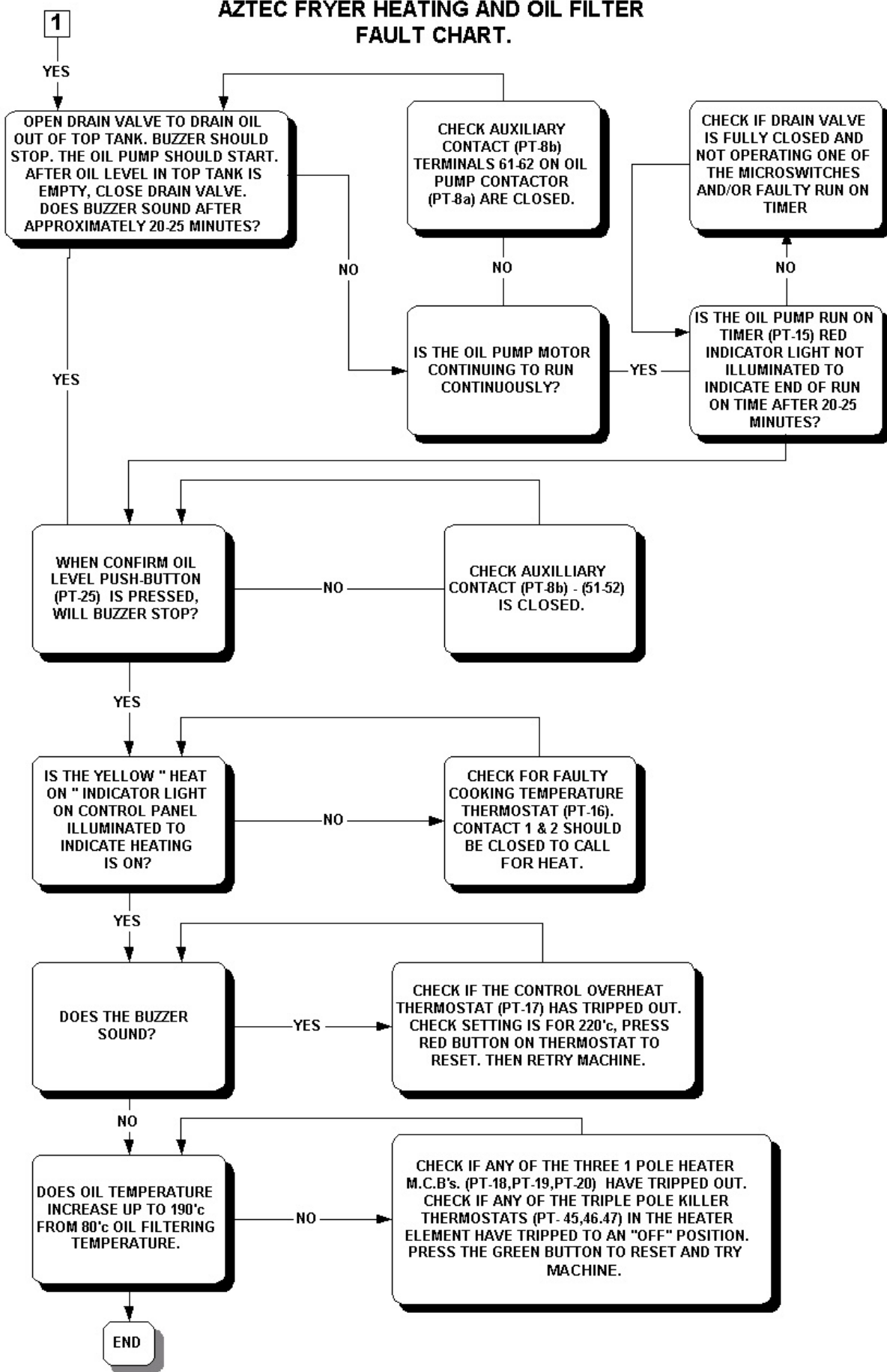

REMEDIES FOR POSSIBLE FAULTS ON AZTEC FRYER UP/DOWN COOKING CYCLE SYSTEM.

The carrier is in the up position.

1) The cooking cycle cannot be started so that the carrier goes down to the first position to start the first cooking cycle. Below are possible causes:-

- a) The carrier is not correctly positioned on pillars and has lifted slightly so inductive sensor(PT-60) on side of arm is covered by the carrier metal so stopping the start of the cooking cycle.
- b) The mid-way down limit switch (PT-42) is jammed in.
- c) Faulty normally closed contact on up contactor auxiliary contact block terminals (61-62).
- d) Faulty electrical/mechanical interlock (PT-6) between up(PT5A) and down contactor (PT7A). With both contactors not energized contacts (21-22) should be closed).
- e) Faulty second cooking time timer (PT-11).

2) The carrier goes down past the midway position to bottom limit and stops. Below are possible causes:-

- a) The midway limit switch (PT-42) plunger has jammed in the in position, clean and retry machine.

3) The carrier goes down to the midway position and stops but will not time out and travel down to the bottom position. Below are possible causes:-

- a) The first cooking time timer (PT-10) is faulty.

4) The carrier goes down to the bottom position and stops but will not time out and return up to top position to remove the cooked doughnuts. Below are possible causes:-

- a) The top limit switch (PT-41) plunger is jammed in, clean and retry machine.
- b) The second cooking time timer (PT-11) is faulty.
- c) Faulty electrical/mechanical interlock (PT-6) between up(PT5A) and down contactor (PT7A). With both contactors not energized contacts (21-22) should be closed).

REMEDIES FOR POSSIBLE FAULTS ON AZTEC FRYER HEATING AND OIL FILTER SYSTEM.

FAULT 1

1) If during the initial switch " ON " of the doughnut cooker the buzzer continually sounds, and pressing the " CONFIRM OIL LEVEL " push-button will not stop the buzzer, check the following below.

The most probable cause is that the oil pump manual starter (PT-3a) has tripped out.

ROTARY BLACK HANDLE WILL BE IS IN THE HORIZONTAL POSITION IF TRIPPED. TWIST CLOCKWISE TO VERTICAL POSITION TO RESET, THEN RETRY MACHINE.

FAULT 2

1) If only the manual valve microswitch (PT34-a) which has 3 wires on it is momentarily actuated after the filtering process has finished, or heating up to 190'c or during any part of the cooking cycle the result is that the buzzer will sound, and the heating will be " off ".

The way to overcome this is to press the " CONFIRM OIL LEVEL " push-button, and the buzzer should stop and the heating up of the oil will continue.

2) If both manual valve microswitches (PT34a and PT34b) are momentarily actuated after the filtering process has finished, or heating up to 190'c or during any part of the cooking cycle the result is that the oil pump will run for 20-25 minutes, then buzzer will sound to get back to cooking cycle press the " CONFIRM OIL LEVEL " push-button, and the buzzer should stop and the machine is now in the 190,c oil temperature mode.

FAULT 3

1) If during the normal operation during any part of the cooking cycle the buzzer continually sounds, and the yellow heat " on " indicator light is " ON " calling for heat (if heat required) the possible cause is as below.

The most probable cause is that the control overheat thermostat (PT-17) has tripped out. Push red reset button in centre of overheat thermostat to reset and then retry machine.

(Intentional blank page)



Queensway
Swansea West Industrial Estate
Swansea,
SA5 4EB, UK

email: spares@monoequip.com
www.monoequip.com
Tel. +44/0 1792 561234

Spares Tel. +44/0 1792 564039

DISPOSAL

CARE SHOULD BE TAKEN WHEN THE MACHINE COMES TO THE END OF ITS WORKING LIFE. ALL PARTS SHOULD BE DISPOSED OF IN THE APPROPRIATE PLACE, EITHER BY RECYCLING OR OTHER MEANS OF DISPOSAL THAT COMPLIES WITH LOCAL REGULATIONS.

(IN UK, ENVIRONMENTAL PROTECTION ACT 1990 APPLIES)