

Eco-Flow ZERO Water Meter



The MONO Eco-Flow ZERO Water Meter has been manufactured to the highest standards and boasts zero water wastage to drain.

Water is a commodity we cannot live without, and due to population growth, changing weather patterns and global warming etc. it is generally accepted around the world that we should try to conserve as much of this expensive and valuable resource as we can. Using the Eco-Flow ZERO Water Meter will help you towards this goal.

This state-of-the-art water meter features a full-colour touch screen control panel which provides a simple user-friendly interface to the many features and benefits inherent in the Eco-Flow ZERO, including the ability to manage product recipes and control up to 2 spiral mixers simultaneously.

There are two models available; FG11-A01 to control spiral mixers and FG11-A02 to work with mixers that have timers.

The Eco-Flow ZERO Water Meter Operates in 2 Modes:

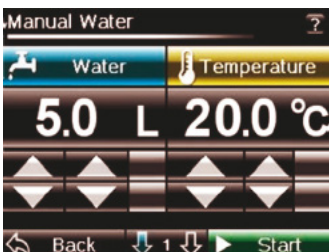

Actual Water Temperature:
This delivers the required volume of water at the pre-selected water temperature

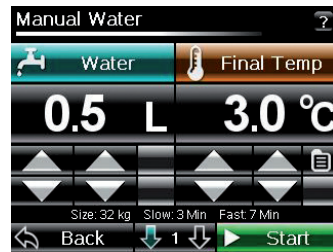

Final Dough Temperature:
This delivers a selected volume of water at the right temperature to achieve a final dough temperature

2 Models Available to Work with:



Mixers Without Timers:
This model can control the whole mixing process of 2 separate mixers including water dosing, mixer speeds and timings.



Mixers With Timers:
This model provides all the functions of the Eco Flow Zero water meter but without the direct control of the mixers



ZERO water wastage technology combined with great energy efficiency



WRAS Product Approved



User-friendly, icon-driven, touch screen navigation with recipe management



Tablet and smart phone controls with air-mirroring technology via an App



Energy monitoring software with real-time management information via KPI screens



Comprehensive Self-Diagnostic screens including alarms & run-time diagnostics



Ethernet connectivity and USB compatible

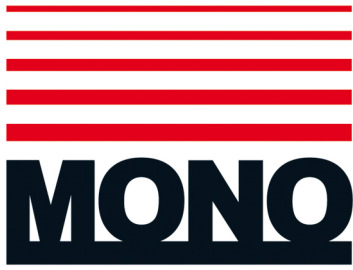

Eco-Flow ZERO Water Meter



Specifications and Dimensions:

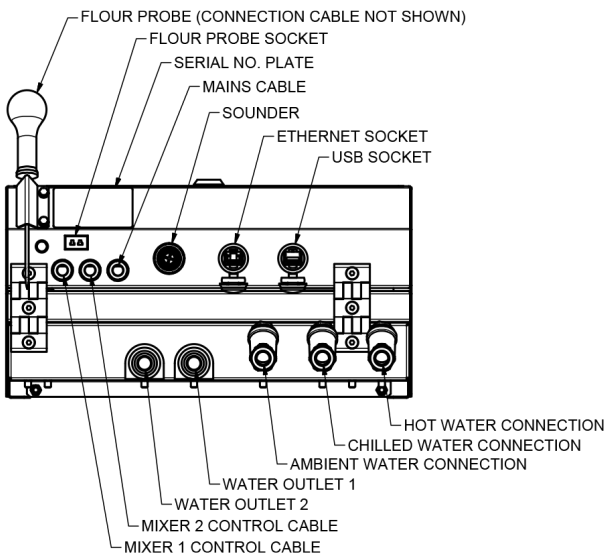
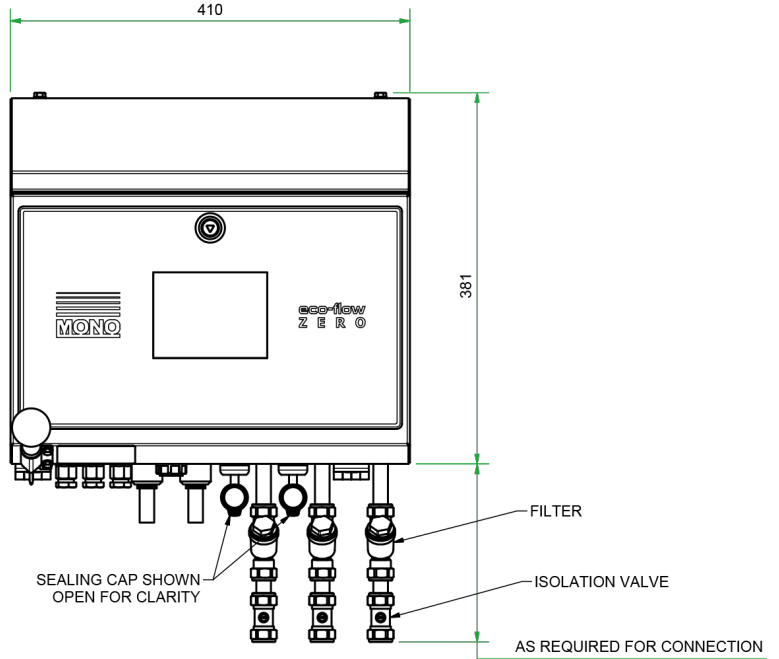
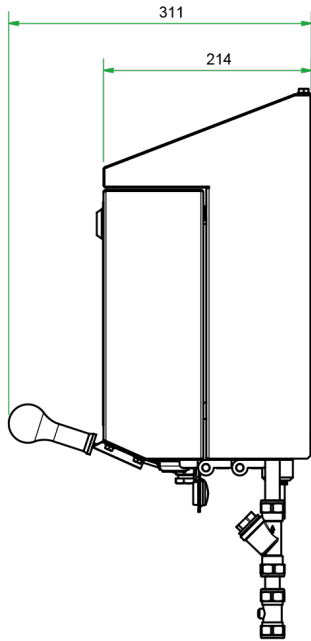

Item	Specification
Supply Voltage	230V AC -240 AC / 110V AC
Fuse Rating	5Amp
USB	2.0
Display Size	5.7"
Display Type	Backlit Colour TFT LCD
Display Resolution	320 x 240 pixels QVGA
Operating Temperature Range	0°C to 50°C (32°F to 122°F)
Weight of Unit	16kg (+ 1kg installation kit)
Weight of Unit Packed	19.8kg (+1kg installation kit)
Minimum Water Inlet Pressure	2 bar
Maximum Water Inlet Pressure	10 bar
Chilled Water Inlet Temperature	Optimum 1°C to 5°C (33.8°F to 41°F) Range 1°C to 10°C (33.8°F to 50°F)
Hot Water Inlet Temperature	Optimum 40°C (104°F) Range 30°C to 60°C (86°F to 140°F)
Ambient Water Inlet Temperature	Optimum 15oC to 30oC (59°F to 86°F)
Water Flow Rate`	Optimum 10-15 Litres/Minute Range 1-20 Litres/Minute
Mixer Connectivity	Up to 2 Escher M60 Premium