



Innovative equipment
for traditional baking



Gemini Two-Pocket Roll Plant with Roll Forming Unit

ROLL PLANTS





The Gemini Fully-Automated Two-Pocket Roll Plant

Effortlessly Produces up to 3,200 Rolls Per Hour



MONO Equipment's Gemini Two-Pocket Roll Plant is designed to effortlessly and reliably produce high volumes of rolls with accuracy and consistency with a generous output of up to 3,200 rolls per hour.

Requiring just one person to set up and operate, the compact Two-Pocket Roll Plant automatically divides and shapes dough pieces within a surprisingly small footprint, making it the perfect solution for small to medium sized bakeries that need a robust, accurate and reliable roll production plant with a high output.



The intuitive colour touch-screen controller stores up to 60 programmes and provides the user with complete control over the dividing, rounding and moulding processes, enabling a wide range of rolls to be produced and is available in 3 different weight ranges:

30g - 100g (1oz - 3½oz)

40g - 110g (1¼oz - 3¾oz)

50g - 145g (1¾oz - 5oz).

To minimise pressure on the dough and prevent over working, specially designed star rollers are used to gently feed the dough from the 15Kg (33lb) hopper to the dividing and rounding chamber.

The addition of the Roll Forming Unit further extends the range of rolls that can be created to include hotdog / finger, petit pain and flattened hamburger rolls, providing true versatility in a single compact unit.

Each built-to-order MONO Two-Pocket Roll Plant is fitted with fail safe interlocked guards to conform to the strictest safety requirements.

7 Superb Features:

- Fully automated dividing and rounding reduces manual labour
- User-friendly and intuitive colour touch-screen controller
- Integrated Flour Duster to aid the clean movement of dough
- Special star rollers which feed the dough with minimum pressure and to reduce over working
- USB Port to save and upload programmes
- Stainless steel construction for durability and ease of cleaning
- Fitted with fail safe interlocked safety guards to conform to the strictest safety requirements for true peace of mind

7 Important Facts:

- Produces a variety of rolls with a weight range of 30g to 100g, 40g to 110g and 50g to 145g
- Effortlessly and accurately produces up to 3,200 rolls per hour
- Stores up to 60 programmes for quick and easy access
- Exceptional accuracy of roll weight, size and shape
- Small footprint makes it the perfect solution for small spaces
- 'Access-to-All-Areas' for simple cleaning and maintenance
- The Roll Forming Unit also moulds hotdog / finger and hamburger rolls

The Gemini Two-Pocket Roll Plant

Provides Accurate, Consistent and Effortless Roll Production



MONO's compact Gemini Two-Pocket Roll Plant has been designed to take the strain and effort out of producing high numbers of rolls with a consistent shape and weight, providing the perfect solution for small to medium size artisan and in-store supermarket bakeries.

The Gemini Two-Pocket Roll Plant is fed via a top-loading 15Kg (33lb) hopper that is flanked by a pair of Flour Dusters which assist with the clean and smooth movement of dough through the machine. A star-wheeled Pre Scaler then gently cuts a piece of dough and softly feeds it into the Filling Chamber where it is pushed by a piston into the pockets and trimmed to size.

The Drum then rotates for the next set of dough pieces whilst the already sized pair of dough pieces come into contact with the Rounding Plates where the rounding process takes place. A magic-eye photocell continuously monitors the feeding of dough from the hopper and ensures the smooth, uninterrupted flow of the dough into the dividing and rounding sections of the plant. The finished dough pieces are then transported from the plant via the two Offtake Belts.

Every stage of the dividing and rounding process is controlled by the intuitive, colour touch screen controller which stores up to 60 programmes for future use; once a Product Recipe has been created and saved, it can be immediately recalled at the touch of an icon.

Two operator-facing Viewing Windows also provides the baker with a safe and easy method of monitoring the dough level in the Hopper and Dividing Chamber whilst the plant is in operation.

As you would expect, the entire Roll Plant is fitted with safety warning labels, safety switches and interlocked safety guards which immediately stop the plant should any of the access points be opened.



The Roll Forming Unit

Extends the Product Range to Include Hotdog / Finger, Hamburger and Petit Pain Rolls



With the addition of the Roll Forming Unit to the Gemini Two-Pocket Roll Plant, the variety of products that can be produced is significantly expanded to include a selection of flattened hamburger rolls, petit pain and elongated hotdog/ finger rolls.

Combining the Roll Plant's capability of producing 30g - 100g (1oz - 3½oz), 40g - 110g (1¼oz - 3¾oz), 50g - 145g (1¾oz - 5oz) dough pieces with the added functionality of the Roll Forming Unit, enables a broad range of perfectly formed rolls to be produced of various weights, sizes and shapes; affording a genuine one-machine-does-it-all solution for the majority of roll manufacturers.

The simple-to-use, manually-set Roll Forming Unit gently carries the formed round rolls from the Roll Plant and takes them on a controlled journey through a number of rollers and non-stick polyester/cotton belts to gradually and systematically reduce their thickness and alter their form until they exit with the required shape and size.

Once the perfect roll specification and profile have been achieved, the values from the rollers and belts can then be transferred and input directly to the Product Recipe Programme on the Gemini Two-Pocket Roll Plant to be saved for future reference, guaranteeing successive rolls are produced with the same consistency and accuracy.

The ergonomic design of the Roll Forming Unit also allows the wheeled offtake belt to be pulled out at an angle whilst in operation to face the baker for ease of traying-up, and then neatly folded away when not in use, saving valuable floor space in the bakery.

Another benefit of the Roll Forming Unit is that it is directly powered via the Gemini Two-Pocket Roll Plant, thereby removing the need for a dedicated power supply of its own.



The Perfect Roll Plant Combination - Providing True Flexibility

7 Key Benefits of MONO's Roll Plant:

- Fully automated dividing and rounding process reduces manual labour
- Dough quality is protected and maintained due to gentle handling
- Produces a seamless finish for an attractive appearance and excellent crumb structure
- Lowers production costs due to improved operational efficiencies
- Special star rollers which feed the dough with minimum pressure to reduce over working
- Effortlessly and accurately produces up to 3,200 rolls per hour
- Produces a variety of rolls with a weight range of 30g - 100g (1oz - 3½oz), 40g - 110g (1¼oz - 3¾oz), 50g - 145g (1¾oz - 5oz)



The specially designed Roll Forming Unit truly transforms the roll plant into a highly versatile roll production factory enabling a huge variety of round, hamburger, petit pain and hotdog / finger rolls to be created from the one machine providing genuine product flexibility.

The compact Gemini Two-Pocket Roll Plant has been designed to take the effort and skill out of producing a wide range of bread rolls with accuracy and consistency. Producing up to 3,200 rolls per hour, this fully-automated dividing and rounding machine is available in 3 different weight ranges:
 30g - 100g (1oz - 3½oz),
 40g - 110g (1¼oz - 3¾oz),
 50g - 145g (1¾oz - 5oz).

The Most Popular Products our Roll Plant can Produce

MONO Equipment's Roll Plant are designed to effortlessly produce an endless array of high quality products.

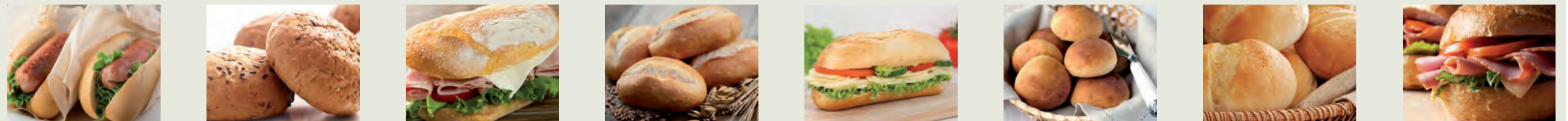

Simple and Intuitive Touch Screen Programming Provides Complete Control of Weight, Shape and Production Speed

The Gemini Two-Pocket Roll Plant - Recipe Screen

The colour touch screen control panel of the Gemini Two-Pocket Roll Plant provides complete control over the dividing and rounding processes. The six columns on the screen each represents a different element of the Product Recipe programme which can be saved for future use.

All of the above settings can be changed at any time during run-time to fine-tune the end results, but will only remain active whilst running and will not overwrite the previously saved Product Recipe programme.

The remaining three coloured icons at the bottom left hand corner of the screen control the Start / Stop, Rounder ON/OFF and access to the Roll Forming Unit control screen.

A handy facility also allows the cost per Kw hour of electricity to be input as a value, allowing the Roll Plant to automatically calculate how many hours have been used along with the total cost of electricity consumed.



Speed - the actual speed the machine is running at

Moulding Pocket Depth - Increase/decrease the moulding pressure

Pre-Scaler Flour Duster - the amount of flour deposited during the hopper feed

Weight - the volume of the dough piece

Conveyor Belt Flour Duster - the amount of flour deposited on the off-take belts

Rounder Plate Speed - the speed of the rounder plate during the rounding process

The Roll Forming Unit - Recipe Screen

The touch screen on the Roll Forming Unit is also very intuitive to use and provides a simple interface to transfer the actual numerical values from the corresponding Roller and Belt Control numbered levers when producing either hotdog / finger or hamburger rolls.

The green icon at the bottom left hand corner of the screen toggles the Upper Belt Speed between standard single speed and double speed. Set to double speed in order to produce finger rolls.

Once the values have been input, they can be saved against that particular Product Recipe Programme for future recall and use.



Initial Roller - used when producing hamburger rolls to take the round roll from the plant and start the flattening process

Secondary Roller - used to incrementally reduce the thickness of the roll further

Finger Roller Positioning Guide - used to correctly position the dough piece when it is dropped onto the lower belts

Top Pressure Belt (Left) - used to take the dough piece down further to the desired thickness for hamburger and hotdog / finger rolls

Top Pressure Belt (Right) - used in combination with the Top Pressure Belt (Left) to achieve the desired result

Unobstructed 'Access-to-all-Areas' Cleaning



MONO's Gemini Two-Pocket Roll Plant and Roll Forming Unit have been designed to provide direct and unimpeded access to all areas, making the regular cleaning process as quick, simple and hassle-free as possible.

All the crucial component parts of both pieces of equipment can be easily accessed via specially designed panels and doors, enabling thorough and hygienic cleaning with the least amount of effort, including the following key areas:

- Flour Dusters
- Dough Hopper
- Pre-Scaler
- Filling Chamber and Filling Piston
- Drum and Rounder
- Pressure Rollers
- Cleaning Brushes
- Oil Reservoir
- Flour Duster Catcher
- Belts, Brushes, Rollers and Guides

Regular and methodical cleaning of the Roll Plant and Roll Forming Unit is essential in order to maintain the highest quality of bread roll production, to ensure peak hygiene standards are upheld and to help maximise the productive lifetime of the machines. Comprehensive step-by-step visual guides and cleaning instructions are provided to make the whole process as simple and straightforward as possible.

Once the main cleaning actions have been completed, any residual flour and small dough fragments can be removed easily from the internal surfaces with the use of a vacuum cleaner. Naturally, as flour dust is highly combustible, we strongly recommend the use of an ATEX approved Safety Vacuum Cleaner.

Just 4 simple cleaning tools are needed:



Brush



Scraper



Vacuum Cleaner



Damp Cloth

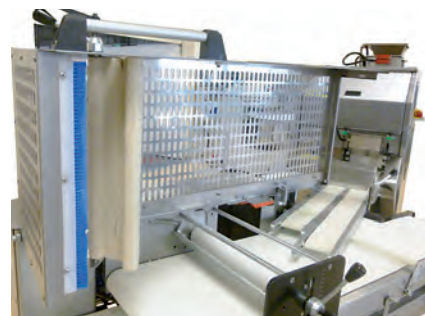

Technical Specifications

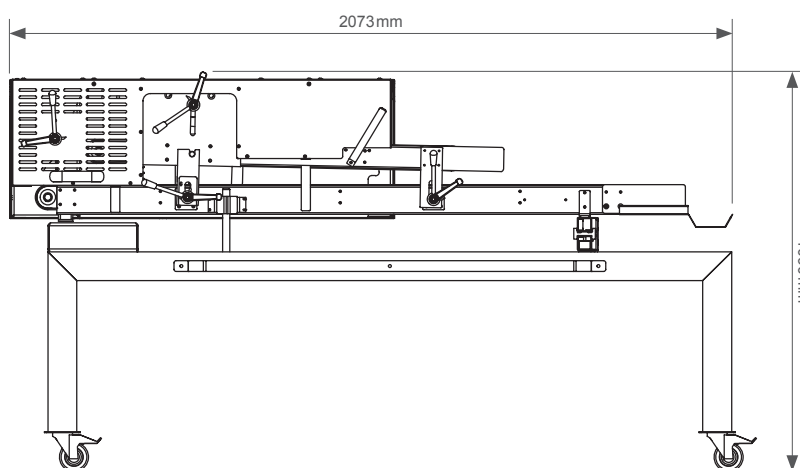
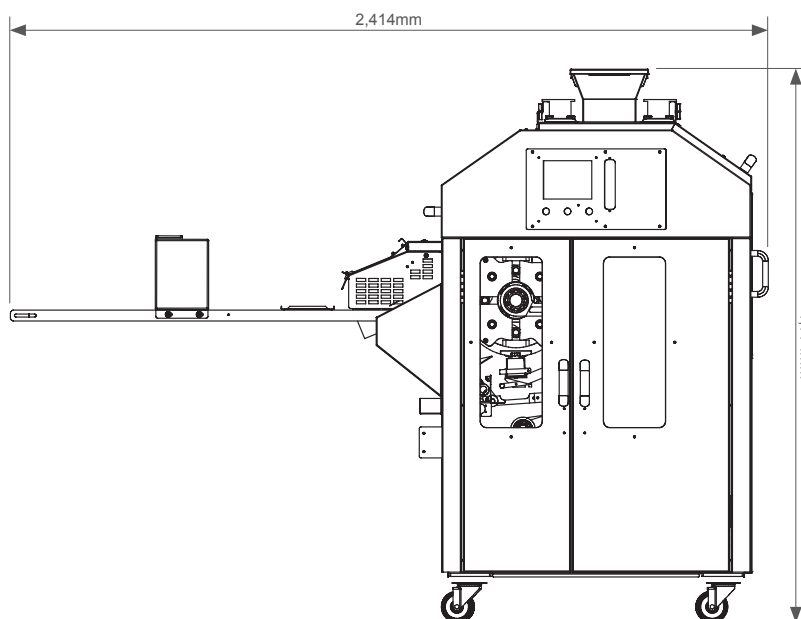

Specifications	
Gemini Two-Pocket Roll Plant	
Length (including switch)	2,414mm (95")
Width (including handle)	799mm (31½")
Height	1,774mm (69¾")
Weight	640Kg (1,410lb)
Roll Weight Range	30 - 100g (1 oz - 3½oz) 40g - 110g (1¼oz - 3¾oz) 50g - 145g (1¾oz - 5oz)
Output Capacity	Up to 3,200 rolls per hour
Piston Diameter	64mm (2½")
Supply Voltage	415V, 3Phase +N +E, 50-60Hz, 1.8kW
Fuse Rating	16Amp
Noise Level	Less than 85dB
Gemini Two-Pocket Roll Plant with Roll Forming Unit	
Length (including switch)	3,073mm (121")
Width - Unit Open	1,142mm (45")
Width - Unit Closed	650mm (25½")
Height	1,774mm (69¾")
Weight	920Kg (2,028lb)
Supply Voltage	2.55kW

Please contact MONO Equipment for USA electrical details.

Specifications correct at time of publication. MONO Equipment reserves the right to amend the specification without prior notice.



MONO Equipment is one of the leading designers and manufacturers of bakery equipment in the United Kingdom. This proud heritage of British craftsmanship, combined with a reputation for creating high-quality, innovative products, can be traced back to its origins in 1947.

MONO Equipment's Gemini Two-Pocket Roll Plant and Roll Forming Unit provide the perfect solution for small to medium sized bakeries who need a robust, accurate and reliable roll production plant with high output and a small footprint.

MONO Equipment also supplies a comprehensive range of convection, deck and rotary rack ovens to suit the needs of most bakery requirements along with everything a modern bakery needs to maximise their profits and efficiencies.



MONO Equipment

Queensway, Swansea West Industrial Park,
Swansea SA5 4EB United Kingdom

Tel: +44 (0)1792 561 234 (Switchboard)

Tel: +44 (0)1792 564 000 (UK Sales)

Tel: +44 (0)1792 564 004 (International Sales)

Tel: +44 (0)1792 564 048 / +44 (0)1792 564 039 (Spares)

Fax: +44 (0)1792 561 016

Email: sales@monoequip.com Web: www.monoequip.com



an Ali Group Company



The Spirit of Excellence