



Enter **Serial No.** here. _____

In the event of an enquiry please quote this serial number.



OPERATION AND MAINTENANCE MANUAL

AUTOMATIC DOUGHNUT FRYER

MANUAL REVISIONS

Revision	Publication Date	Author	Description
A25	07-DEC-2025	CD	New photograph of the automatic doughnut fryer.



Declaration of Conformity



We the manufacturer: **MONO EQUIPMENT**
Queensway,
Swansea West
Industrial Park,
Swansea
SA5 4EB
UK

Machine:

FG Code:

Serial No:

Hereby declare that this machine conforms with and complies with the following directives:

- The Machine Directive **2006/42/EC**
- The Low Voltage Directive **2014/35/EC**
- The Electromagnetic Compatibility Directive 2014/30/EU Incorporating Standards **EN 55014-1:2017/A11:2022 & EN 55014-2:1997+A1:2001+A2:2008**
- The General Safety of Machinery and Food Processing Standards
- Materials and Articles Intended to Come into Contact with Food – Regulation **(EC) No. 1935/2004**
- Good Manufacturing Practices (GMP) for Materials Intended to Come into Contact with Food
- Regulation **(EC) No. 2023/2006**

A technical construction file for this machine is retained at MONO Equipment

MONO Equipment is a business name of **AFE Group Ltd** Registered in England No. 3872673

VAT Registration No. 923428136

Registered office: Unit 35,
Bryggen Road,
North Lynn Industrial Estate,
Kings Lynn Norfolk,
PE30 2HZ

Mr Craig Petherbridge
Quality & Compliance Manager

Mr Alex Davies
Engineering Manager

QD 001

Dated 01/11/2022

SAFETY SYMBOLS

The following safety symbols are used throughout this product documentation and manual (available at www.monoequip.com).

Before using your new equipment, read the instruction manual carefully and pay special attention to information marked with the following symbols.



WARNING

Indicates a hazardous situation which, if not avoided, will result in death or serious injury.



WARNING

Indicates a hazardous situation which, if not avoided, will result in electric shock.



CAUTION

Indicates a hazardous situation which, if not avoided, will result in minor or moderate injury.

**DO NOT POUR USED OIL
DOWN DRAINS OR SINKS.**



IMPORTANT NOTES



Special attention should be given to the bottom of the top tank so that a layer of sediment is not allowed to build up. As the temperature sensors will not be able to function correctly, a fire could result.

Do not mix different makes or types of frying oil as a reaction can result in a thick flour-like sediment forming in the lower tank which can block the filtering system.



ELECTRICAL SAFETY AND ADVICE REGARDING SUPPLEMENTARY ELECTRICAL PROTECTION

Commercial bakeries, kitchens and food service areas are environments where electrical appliances may be located close to liquids, or operate in and around damp conditions, or where restricted movement for installation and service is evident.

The installation and periodic inspection of the appliance should only be undertaken by a qualified, skilled and competent electrician, and connected to the correct supply suitable for the load as stipulated by the appliance data label.

The electrical installation and connections should meet the necessary requirements of the local electrical wiring regulations and any electrical safety guidelines.

We Recommend:

- Supplementary electrical protection with the use of a residual current device (RCD)
- Fixed wiring appliances incorporate a locally situated switch disconnector to connect to, which is easily accessible for switching off and safe isolation purposes. The switch disconnector must meet the specification requirements of IEC 60947.

Your attention is drawn to:

BS 7671:2018 – Guidance Note 8 – 8.13: Other locations of increased risk

It is recognised that there may be locations of increased risk of electrical shock other than those specifically addressed in Part 7 of BS 7671. Examples of such locations could include laundries where there are washing and drying machines in close proximity, and water is present, and commercial kitchens with stainless steel units, where once again, water is present. Where, because of the perception of additional risks being likely, the installation designer decides that an installation or location warrants further protective measures, the options available includes:

- Automatic Disconnection of Supply (ADS) by means of a residual current device having a residual operating current not exceeding 30 mA;
- Supplementary protective equipotential bonding; and
- Reduction of maximum fault clearance time.

The provision of RCDs and supplementary bonding must be specified by the host organisation's appointed installation designer or electrical contractor and installed by a suitably qualified and competent electrician so as to comply with Regulations 419.2 and 544.2.



The supply to this machine must be protected by a **30mA-rated Type A RCD**



Safety during emptying and cleaning of fryers

HSE information sheet

Introduction

This information sheet was produced by the Hospitality and Catering Industry Liaison Forum, which has members from trade and professional associations, unions and enforcement authorities. Members' associations are free to reproduce and distribute this guidance to catering establishments. The guidance is issued by the Health and Safety Executive.

This sheet provides advice to employers in the catering industry on safe emptying and cleaning of fryers. It gives guidance on manual emptying and cleaning and guidance on fryers with automated or semi-automated filtering (using enclosed portable filtering units).

Automated and semi-automated filtering processes avoid operators coming into contact with hot oil, significantly reducing the risks. This enables filtering to take place safely even while the oil is at normal cooking temperature. Most automated or semiautomated systems require an oil temperature of at least 100 °C for the filtering process to work effectively.

You should only carry out manual emptying and filtering of fryers when the oil has been cooled to 40 °C or below.

Key messages

- ■ Burns from hot oil can be very serious.
- ■ Oil takes only 6–7 minutes to heat up but can take 6–7 hours to cool down again.

What the law says

The Health and Safety at Work etc Act 1974 (the HSW Act) places a duty on employers to ensure, so far as reasonably practicable, the health, safety and welfare of their employees. This duty extends, amongst other things, to providing and maintaining systems of work which are, so far as reasonably practicable, safe and without risks to health. The HSW Act also places a duty on employees to take reasonable care of their own and others' health and safety.

Whichever type of fryer is used, you must:

- ■ ensure the fryer is well maintained and any attachments used are suitable for their purposes, as recommended by the manufacturer – a procedure for reporting faults will help you comply with this duty;
- ■ train staff in a safe system of work for emptying and cleaning;
- ■ provide staff with suitable protective equipment where required by the risk assessment, eg eye protection, heat-resistant gloves, aprons.

When to empty and clean

■ ■ Many catering establishments are closed overnight. For fire safety and economy switch off fat fryers when unattended. Carry out oil filtering and cleaning as a **first task of the day rather than as part of the closing-down procedure.**

Hazards

The hazards in emptying and cleaning fryers include:

- ■ fire;
- ■ burns from hot oil;
- ■ contact with hot surfaces;
- ■ fumes from boiling cleaning chemicals;
- ■ boiling chemicals overflowing;
- ■ eye injuries from splashes;
- ■ slips from oil spillage;
- ■ strains and sprains from lifting and moving containers of oil. If the catering service runs for 24 hours and the appliance is required continuously, there are two safe options:

Page 2 of 4

- ■ Use more than one fryer and clean them in rotation.
- ■ Use an automated filtering system or a semiautomated portable filtering unit that removes the hot oil directly from the fryer, filters the oil and holds it safely.

Automated and semi-automated filtering

Automated filtering systems

An automated system consists of an inbuilt oil filtration system. The oil is drained into an enclosed reservoir and an electric pump circulates it through a filter system and internal pipework back into the fryer.

Since this process is enclosed within the equipment, the operator does not come into contact with hot oil, greatly reducing any risk.

Portable oil filtering units (semi-automated)

These units are not part of the fryer, but sit alongside it. The operator attaches an extension pipe to the fryer and the hot oil is drained into an **enclosed** container within the portable unit. The oil is then filtered and returned to the fryer.

If you have a fryer with automated oil draining system or a portable oil filtering unit, refer to the manufacturer's guidelines for draining/filtering temperatures and safe operational requirements.

These, together with your own risk assessment, will determine the need for suitable protective equipment. If there is still a risk from contact with hot surfaces or oil splashing, you may need to provide staff with eye protection, a protective apron and/or heat-resistant gloves/gauntlets.

Manual oil filtering

This involves the operator draining the oil from the fryer through a filter into a suitable metal-holding or heat-resistant hard, plastic container and manually lifting it back into the fryer (fryer oil is often supplied in hard, plastic, rigid containers). Serious accidents have occurred where oil that has not sufficiently cooled has been drained back into an empty plastic container and the base of the container has given way.

To drain oil safely and in the correct sequence, follow these guidelines:

- ■ Turn off the appliance and the power supply at the wall socket for electric appliances, and the on/off control for gas appliances.
- ■ Allow the oil to cool, ideally for at least six hours, and check the temperature using a suitable probe thermometer before draining. Do not drain if the temperature is above 40 °C.
- ■ Follow the manufacturer's instructions and use the correct equipment (eg a detachable spout for the type of fryer you are emptying), making sure to bring any equipment you need to the fryer before you start.
- ■ Depending on the type of fryer, drain the oil by drain valve, removable spout, lifting container or by tilting.
- ■ If the oil is too cold to drain easily, reheat it briefly and agitate with the fryer basket for no more than one minute. Switch the appliance off and check the temperature again before emptying.
- ■ Using a filter, run the oil into a suitable metal holding or heat-resistant hard, plastic container. These containers will generally need carrying handles and a cover or lid. Before moving, make sure that the lid or cover is secure.
- ■ Make sure the container is empty and big enough to take the volume of oil being drained at any time.
- ■ When you are draining large volumes of oil it is safer to drain off in smaller amounts. This avoids overfilling the container and will reduce the chance of spillages when you move it. Smaller amounts will also be easier to carry.
- ■ Place the container in a safe place where it cannot be contaminated with chemicals, water or foreign bodies. Place the container on top of a drip tray to avoid any floor contamination.
- ■ Do not dispose of waste oil down the drain – disposal must comply with environmental legislation.
- ■ Clean up any spillages **immediately**.
- ■ Make sure floor areas around equipment are completely clean and dry to avoid slip risks (see also *Preventing slips and trips in kitchens and food service*).

Other precautions

Make sure the design of the drain-off tap prevents it being turned on accidentally:

Page 3 of 4

- ■ Mark clearly on it that the tap should not be touched.
- ■ Place warning signs near the tap.
- ■ If possible, remove the tap handle when the fryer is switched on.

Cleaning procedure

This section applies to all types of fryers.

- ■ Turn off the appliance, and the power supply at the wall socket for electric appliances and the on/off control for gas appliances.
- ■ Wear suitable protective equipment, including eye protection (if appropriate).
- ■ Check that other activities will not be put at risk by the cleaning activity.
- ■ Check that the oil has been thoroughly drained and that there are no spillages that may cause slipping.
- ■ Remove loose debris from the internal surfaces.
- ■ Thoroughly wash all internal and external surfaces with suitable cleaning chemicals and check for any leaks.
- ■ For stubborn residues, fill the fryer with your recommended cleaning agents and leave or simmer according to instructions.
- ■ Do not leave the fryer unattended or allow it to boil as this may cause it to cascade liquid onto the floor, causing additional scalding and slipping hazards.
- ■ Drain the appliance and rinse thoroughly with plenty of water.
- ■ Dry all internal surfaces and make sure there is no water left in the fryer.
- ■ Check the drain valve is closed and working properly, then refill and switch on as required.
- ■ When refilling the fryer with oil, the oil container may be too large or heavy for one member of staff. Where possible, use smaller containers.
- ■ Do not overfill the fryer. Follow the manufacturer's guidelines.
- ■ Clean up any spillages **immediately**.
- ■ Make sure floor areas around the equipment are completely clean and dry to avoid slip risks.

Training

This section applies to all types of fryers.

- ■ Make sure only staff trained in the safe use of the cleaning chemicals and cleaning procedures for the fryer do this task.
- ■ Train staff in reporting procedures if they find the equipment is faulty or if they have experienced any practical difficulties with cleaning the fryer in their specific work environment.
- ■ Make staff aware of the reason for using suitable protective equipment, ie gloves, eye protection.
- ■ Complete risk assessments for hazardous chemicals and make staff aware of the correct procedures for using cleaning chemicals.
- ■ Make safety data sheets available to staff.
- ■ A short, written procedure can act as a reminder to staff for both draining and cleaning operations.

Further reading

Preventing slips and trips in kitchens and food service

Catering Information Sheet CASI6(rev2) HSE 2012

www.hse.gov.uk/pubns/cais6.htm

Safe use of cleaning substances in the hospitality industry Catering Information Sheet CAIS22(rev2)

www.hse.gov.uk/pubns/cais22.htm

HSE has produced a suite of Catering Information Sheets and other guidance for the catering and hospitality industry. These are available on the HSE website at www.hse.gov.uk/catering/index.htm

There is also helpful advice in Health and safety made simple: The basics for your business

www.hse.gov.uk/simple-health-safety

CONTENTS

Section - 1.0	Introduction
Section - 2.0	Overall Dimensions
Section - 3.0	Specifications
Section - 4.0	Safety
Section - 5.0	Installation
Section - 6.0	Isolation
Section - 7.0	Cleaning Instructions Draining cooking oil / molten fat
Section - 8.0	Operating instructions Machine controls Auto mode Manual mode Float frying
Section - 9.0	Maintenance
Section - 10.0	Service and spares
Section - 11.0	Spares Information
Section - 12.0	Electrical Information

1.0 INTRODUCTION

The **MONO** fryer makes the doughnuts, you make the profits - it's as easy as that. Just set the controls, load a tray and the **MONO** Automatic takes over. Up to 900 doughnuts can be produced every hour with the minimum of supervision.

The **MONO** Fryer saves on cooking oil and electricity, as only the oil in the vicinity of the frying basket is heated to full working temperature, and is thermostatically controlled.

2.0 DIMENSIONS

Height:	Immersion frying unit in raised position	1232mm (48½").
	Float frying unit in raised position	1232mm (48½").
	Float frying unit with manual turnover device in raised position	1550mm (61").
Width:	Left hand fitted draining board	1892mm (74½).
	Right hand fitted draining board	1772mm (67¾).
	Two draining boards fitted	2521mm (99").
Depth:		762mm (30").

3.0 SPECIFICATIONS

Power: 12.37 kW; three phase



The supply to this machine must be protected by a **30mA-rated Type A RCD**

Output: Float frying - up to 675 doughnuts per hour.
Immersion frying - up to 900 doughnuts per hour.

Capacity: 45 doughnuts per tray.

Frying tank capacity: 77.25 litres (17 gallons)

Frying trays: 762mm x 457mm (30" x 18").

Weight: 160kg (353lb).

Noise level: Less than 85dB.

4.0 SAFETY



Before work is commenced.

In the interests of safety and efficient operation of this fryer, it is essential that this manual should be made available to all personnel who may be required to operate it,

The following points should be closely observed and rigorously pursued at all times

- 1 Never use the fryer in a faulty condition and always report any damage.
- 2 No-one under the age of 16 may operate this machine.
- 3 No-one under the age of 18 may clean this machine under any circumstances.
- 4 Only trained personnel may remove any part from this fryer that requires a tool to do so.
- 5 Always ensure hands are dry before touching any electrical appliance (including cable, switch and plug).
- 6 All operatives must be fully trained.
- 7 People undergoing training on the machine must be under direct supervision.
- 8 Do not operate the machine with any panels removed.
- 9 All guards must be fixed in place with bolts or screws unless protected by a safety switch.
- 10 No loose clothing or jewellery to be worn while operating the fryer.
- 11 Switch off power at the mains isolator when fryer is not in use and before carrying out any cleaning or maintenance.



ALL CLEANING AND MAINTENANCE OPERATIONS MUST BE MADE WITH FRYER DISCONNECTED FROM THE POWER SUPPLY

- 12 The Bakery Manager or the Bakery Supervisor must carry out daily safety checks on the fryer.

5.0 INSTALLATION

- 1 It is recommended that the Automatic Doughnut Fryer should be sited away from any main thoroughfare and that the surrounding floor area should be covered with a proprietary brand of non-slip surfacing.
- 2 Ventilation should be provided with an extraction canopy to ensure that convected heat and cooking smells are removed from the building. The canopy should extend a minimum of 300mm (12") beyond each edge of the fryer and have its lowest point between 1980mm (78") and 2740mm (108") above the floor. The extraction canopy should be fitted with a grease trap.
- 4 Fittings are provided at both ends of the fryer for the attachment of draining boards
- 5 The fryer should be connected to a 20 Amp, 3 phase plus neutral isolator at 20amp with a BS 88 fuse.



The supply to this machine must be protected by a **30mA-rated Type A RCD**

VERY IMPORTANT INSTRUCTION. DAMAGE COULD OCCUR IF NOT FOLLOWED

- 6 Automatic doughnut fryers are despatched with the carrier (1) in the mid way position to avoid damage during the following check procedure:
- 7 Set toggle switch (2) to 'AUTO' position.
- 8 Set toggle switch (3) to 'UP / OFF' position.
- 9 Turn main control switch (4) to 'ON' (vertical position).
- 10 Briefly switch toggle switch (3) to 'ON / DOWN' position, and then back again. If the carrier (1) moves upwards, motor rotation is correct. If the carrier moves downward, transpose any two of the three-phase carrying wires at the mains isolator feeding the fryer.

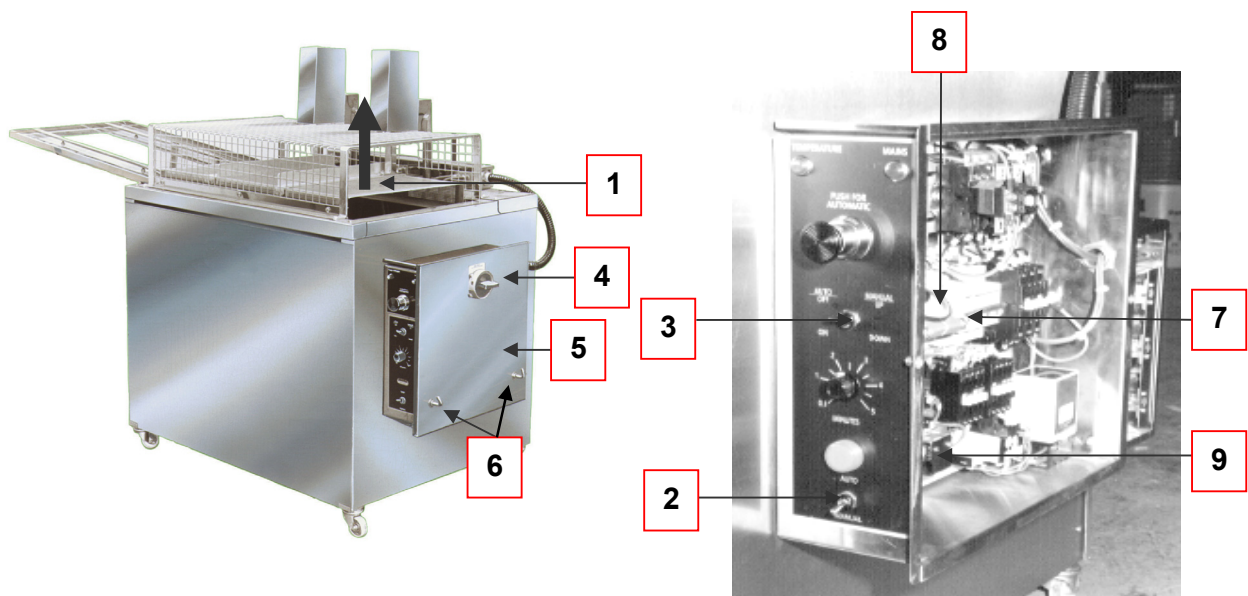

- 11 Turn main isolator switch (4) to 'OFF' (horizontal position).
- 12 Remove two screws (5).
- 13 Remove cover (6).
- 14 Reset heater contactor circuit breaker (7) upwards to the 'ON' position.
- 15 Whilst cover (6) is removed, check that the two thermostats are set correctly as below.

FRYING THERMOSTAT (8) SHOULD BE SET FOR 180° C.

SAFETY OVER-RIDE THERMOSTAT (9) MUST BE SET AT 210° C MAXIMUM.

16 Replace cover and fixing screws.

- 17 Fill tank with cooking oil/fat to a level no higher than 75mm (3") from the top of the frying tank and no lower than 85mm (3 3/8"). There are "MAX" and "MIN" oil level indications located inside each end of the frying tank.

NOTE: To avoid damage to the heating element when filling the machine with solid fat, break up fat and melt gradually by replacing side panel and cycling machine on and off for 15 seconds periods, until the elements are completely immersed.

- 18 Switch on main isolator switch (4)

Red mains indicator lamp (10) and amber temperature indicator lamp (11) will illuminate, indicating that oil/fat is heating.

Once working temperature is reached, amber lamp (11) will extinguish.

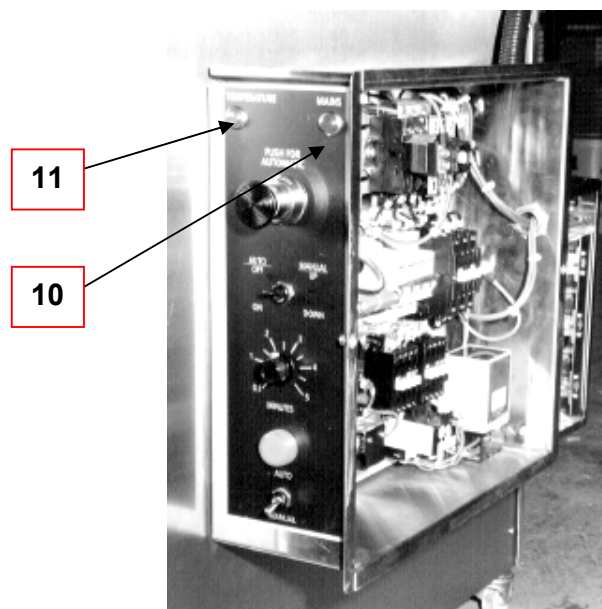

6.0 ISOLATION

To stop the Doughnut Fryer in an emergency switch off at the mains wall isolator.

7.0 CLEANING INSTRUCTIONS

AND DRAINING COOKING OIL/MOLTEN FAT

WARNING:



HOT OIL IS DANGEROUS. ALLOW OIL TO COOL BEFORE ATTEMPTING TO CLEAN THIS MACHINE.

ISOLATE FRYER FROM MAINS SUPPLY BEFORE CLEANING

- 1 Wipe down exterior metalwork with a damp cloth.
- 2 While fat is still liquid (not hot), heating unit may be lifted out of the tank. This can be cleaned as a separate item. Do not immerse in water.
- 3 Drain the tank into suitable containers as follows:

Remove two screws (12).

Remove front cover (13)

Place a collection container under the drain valve (14).

Open the drain valve (14) by turning in direction indicated and drain out contents of frying tank. Do not leave the tank draining and walk away, the tank will hold more than the container, which will need to be changed at regular intervals. Use the tap to turn off the oil flow between each container change.

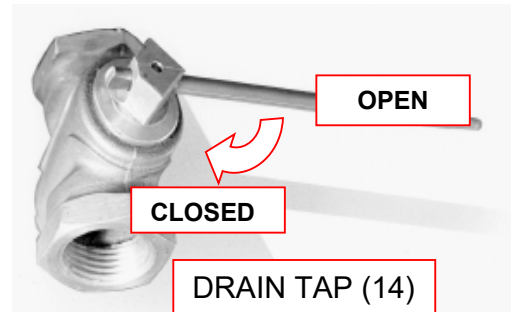
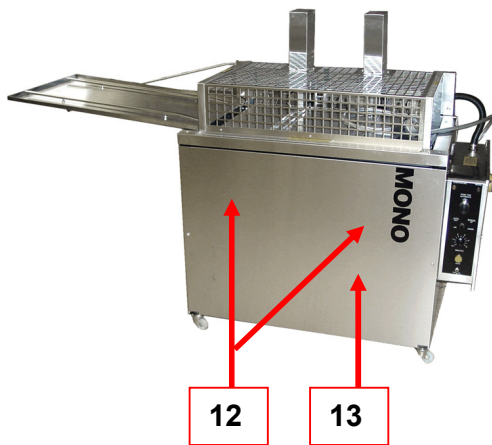

8.0 OPERATING INSTRUCTIONS

MACHINE CONTROLS

- 1 When toggle switch (2) is in the 'AUTO' position and toggle switch (3) is set to 'ON', depressing control button (15) starts the frying sequence, governed by timer (16).
- 2 When toggle switch (2) is in the 'MANUAL' position, toggle switch (3) controls the up and down movement of the carrier.

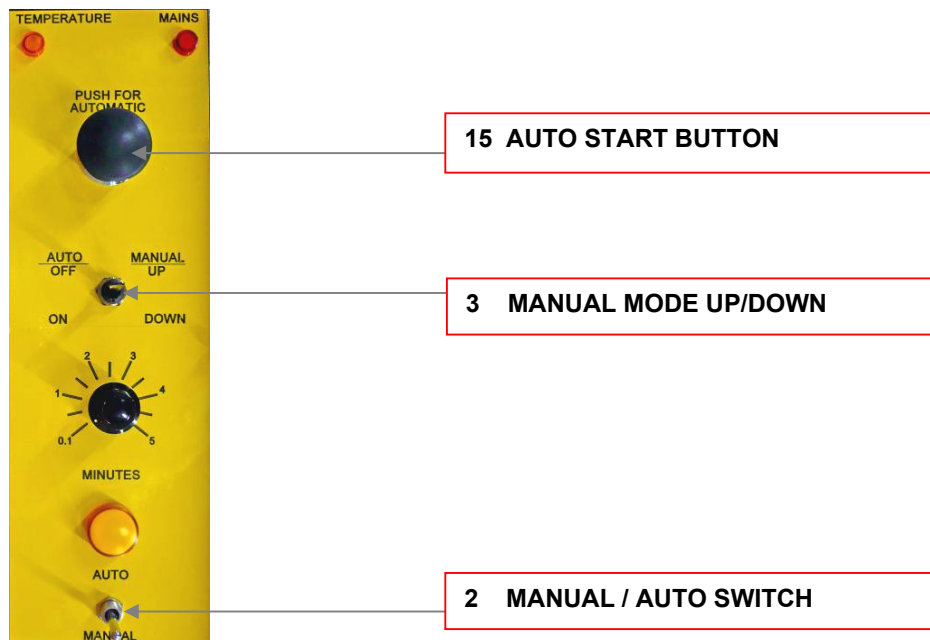

- 3 A mains isolator (4) is provided, which must be switched to 'OFF', (horizontal position) before cover (6) can be removed

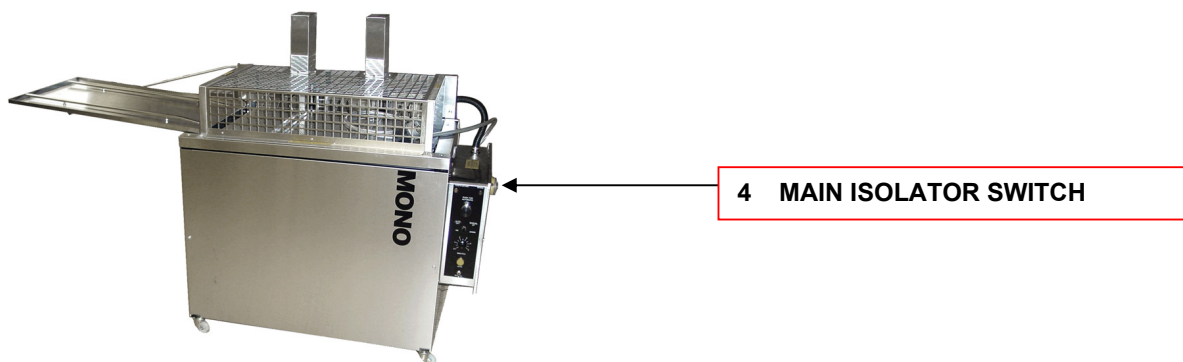

AUTOMATIC MODE

- 1 Turn main isolator switch (4) vertically to 'ON' position.
- 2 Set toggle switch (2) to 'AUTO'.
- 3 Set toggle switch (3) to 'ON'.
- 4 Set timer (16) to frying time required.
- 5 Wait for oil to heat up.
When indicator lamp (11) extinguishes, frying temperature has been reached.
- 6 Slide tray into basket.
- 7 Press control button (15) to **start** frying sequence.

NOTE:

IN AN EMERGENCY, TOGGLE SWITCH (3) MAY BE SWITCHED TO 'OFF' TO HALT CARRIER TRAVEL IRRESPECTIVE OF POSITION.

- 8 When tray returns to the top slide off tray on to drainer.

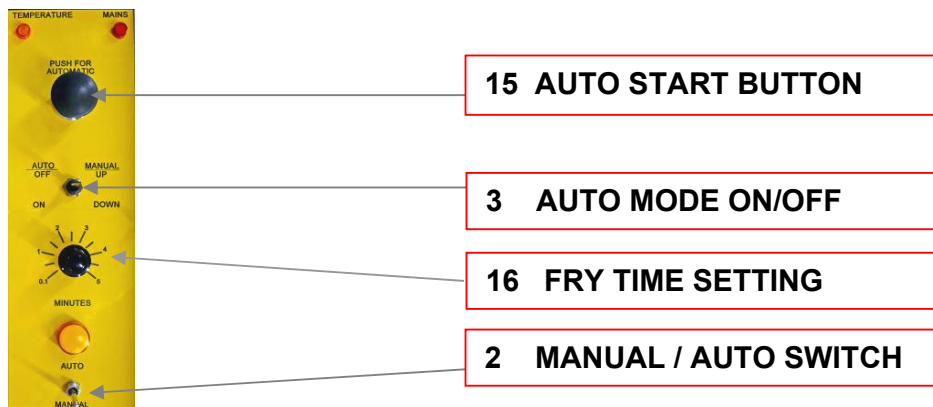
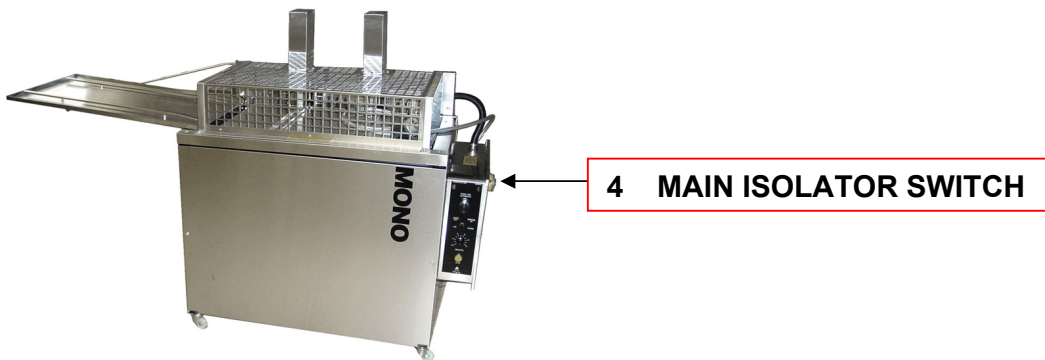

MANUAL MODE

- 1 Turn main control switch (4) vertically to 'ON' position.
- 2 Wait for oil to heat up.
When indicator lamp (11) extinguishes, frying temperature has been reached.
- 3 Slide tray into basket.
- 4 Set toggle switch (3) to 'down' (carrier will lower)
- 5 When required fry time has been reached, move toggle switch (3) to 'up' and carrier will rise. Slide tray on to drainer.

NOTE:

IN AN EMERGENCY, TOGGLE SWITCH (3) MAY BE SWITCHED TO 'OFF' TO HALT CARRIER TRAVEL IRRESPECTIVE OF POSITION.

- 7 When tray returns to the top slide off tray on to drainer.



4 MAIN ISOLATOR SWITCH

11 TEMPERATURE LIGHT



15 AUTO START BUTTON

3 MANUAL MODE UP/DOWN

16 FRY TIME SETTING

2 MANUAL / AUTO SWITCH

TO CONVERT THE MACHINE FOR FLOAT FRYING:

- 1 Switch off mains isolator. (4)
- 2 Remove guard screws.
- 3 Remove guard (17).
- 4 Lift off carrier assembly (18) from pillars (19).
- 5 Replace with float frying carrier assembly.
- 6 Replace guard and screws before attempting to use the machine.

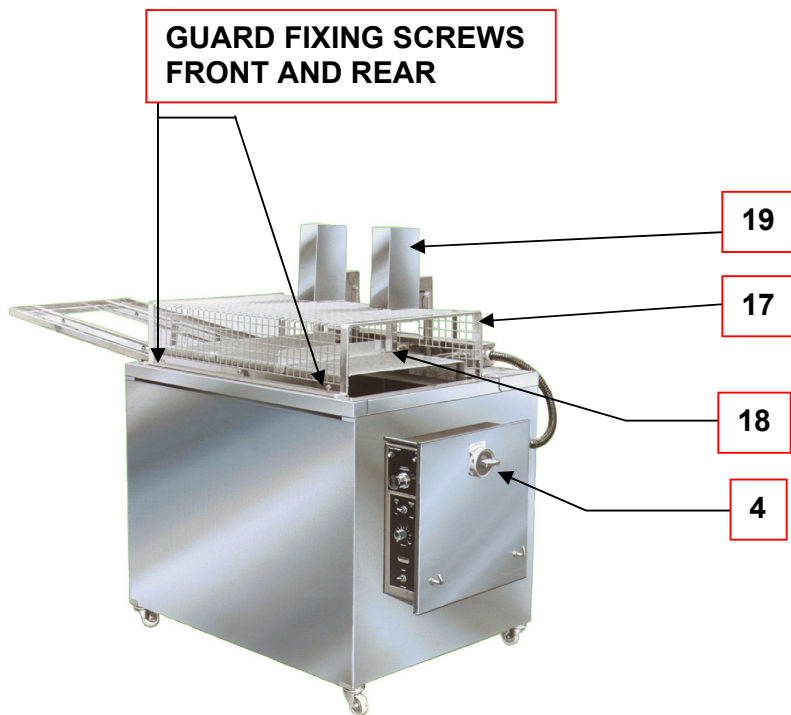

9.0 MAINTENANCE



WARNING

- This appliance must be maintained at regular intervals. The frequency of maintenance will depend upon your specific use and location. The maximum service interval should be 12 months.
- Service and maintenance should only be undertaken by suitably qualified, trained, and competent engineers.
- You must immediately report any damage or defect arising with the appliance.
- Unsafe equipment is dangerous. Do not use the appliance. Isolate the power supply and contact **MONO** or your appointed service agent.

The fryer must not be used if bare cables are visible. Follow cleaning instructions.

Twice yearly



- 1 Isolate machine from mains supply.
- 2 Remove back sheet and grease drive shaft (**20**) and guide shafts (**21**) with high temperature grease.
- 3 Replace back sheet before starting machine.

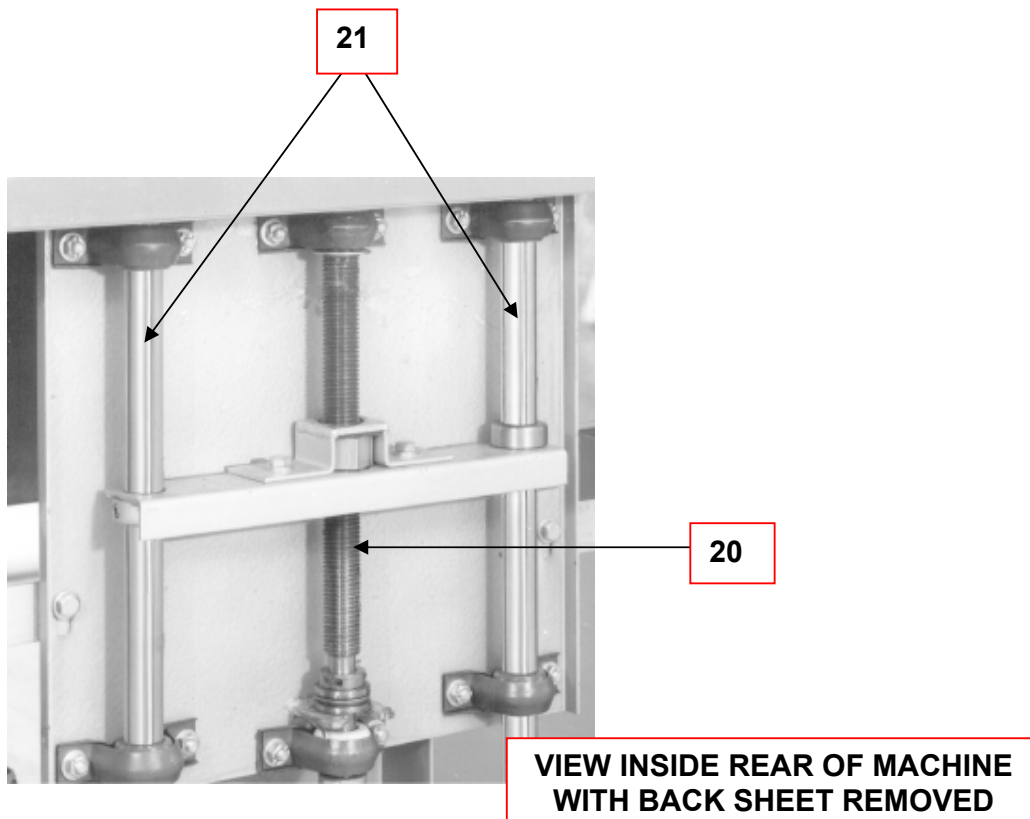

10.0 SERVICE AND SPARES ---

If a fault arises, please do not hesitate to contact the
Customer Service Department, quoting the **machine serial number**
on the silver information plate of the machine and on the front cover of this manual

SPARES and OVERSEAS SUPPORT:

MONO

Queensway
Swansea West Industrial Estate
Swansea.
SA5 4EB
UK

email: spares@monoequip.com
Spares Tel. +44(0)1792 564039

Web site: www.monoequip.com

Main Tel. 01792 561234



11.0 SPARES INFORMATION

IF IN ANY DOUBT - ASK	PT-REF	QUANTITY	DESCRIPTION	PART No.	LABELLED
	PT-1	1	MAIN ISOLATOR SWITCH	B807-07-007	ON/OFF
	PT-2	1	HEATER CONTACTOR	B801-08-034	
	PT-3 /4	1	UP/DOWN CONTACTOR	B801-08-033	
	PT-5	1	ELECTRICAL/MECHANICAL INTER-LOCK FOR UP DOWN CONTACTOR	B801-18-005	
	PT-6	1	MAIN MOTOR OVERLOAD	B801-01-043	MAINS
	PT-7	1	MAINS ON INDICATOR LIGHT	B842-43-001	TEMPERATURE
	PT-8	1	TEMPERATURE INDICATOR LIGHT	B842-43-002	
	PT-10	1	HEATER CONTACTOR C/BREAKER	B872-22-001	
UP TO Sept 2003	PT-10	1	AUTOMATIC PUSH BUTTON	B808-12-001	
	PT-10a-1	1	AUTOMATIC PUSH BUTTON	B801-12-039	AUTOMATIC
	PT-10b-1	1	CONTACT BLOCK	B801-14-002	
	PT-10c-1	1	ADAPTOR KIT	B801-18-003	
	PT-11	1	UP LIMIT SWITCH BODY	B801-11-013	
	PT-12	1	UP LIMIT SWITCH ACTUATOR	B801-45-005	
	PT-13	1	DOWN LIMIT SWITCH BODY	B801-11-013	
	PT-14	1	DOWN LIMIT SWITCH ACTUATOR	B801-45-006	
	PT-15	1	IMMERSION TIMER	B819-34-004	
	PT-15	3	MAIN MOTOR CIRCUIT BREAKER	B872-22-052	
UP TO Sept 2003	PT-15	3	HEATER CIRCUIT FUSE	B823-39-001	
	PT-16	3	HEATER CIRCUIT MCB	B872-22-008	
	PT-17	1	COOKING TEMP THERMOSTAT	B873-30-002	
	PT-18	1	EXCESS TEMP THERMOSTAT	B873-30-001	
	PT-19	1	AUTO/MANUAL TOGGLE SWITCH	B816-07-001	AUTO/MANUAL
	PT-20	1	OFF/UP DOWN/ON TOGGLE SWITCH	B816-07-006	OFF/UP ; ON/DOWN
	PT-21	3	IMMERSION TIME POTENTIOMETER	B842-59-007	0-5 MINS
	PT-22	3	IMMERSION ELEMENTS 240V	B906-04-001	
	PT-23	3	IMMERSION ELEMENTS 220V	B906-04-005	
	PT-27	1	OVERHEAT BUZZER	B883-92-001	
	PT-27	1	AMBER LENS } OVERHEAT LIGHT	B801-44-007 }	OVERHEAT
	PT-27	1	LENS BODY }	B801-43-012 }	
	PT-27	1	MAIN UP/DOWN MOTOR	B859-74-033	

D	RAC	30-01-12	motor B859-74-033 vrs 009	IM-001-12
C	JC	25-06-07	CONTACTORS & O/LOADS B801 WERE B859	3011
B	RAC	24-09-03	SEE ECN's 1948/1949	
A	PB	1-9-93	ITEMS 11 & 12 WERE B809-11-001	4441
REV	SIG	DATE	REVISION	ECN NO.

 QUEENSWAY SWANSEA WEST IND PARK SWANSEA, SA5 4EB. TEL: (01782) 561234 FAX: (01782) 561016		TITLE: AUTOMATIC DOUGHNUT COOKER COMPONENTS PARTS LIST
ELECTRICAL SPECIFICATIONS:-		DRAWN: REVISION
380-4,15V		ELECTRICALLY APPROVED BY:-

REVISION ON CAD 10-98

COPYRIGHT © 1998 - THIS DESIGN/DRAWING IS THE PROPERTY OF MONO EQUIPMENT LTD. AND MUST NOT BE REPRODUCED, COPIED, NOR ITS CONTENTS DIVULGED WITHOUT PRIOR WRITTEN PERMISSION.

IF IN ANY DOUBT - ASK				DESCRIPTION	QUANTITY	PT-REF	PT-REF	QUANTITY	DESCRIPTION	PART No.	LABELLED
				MAIN ISOLATOR SWITCH	1	PT-1	B807-07-007	1	MAIN ISOLATOR SWITCH	B807-07-007	ON/OFF
				HEATER CONTACTOR	1	PT-2	B801-08-034	1	HEATER CONTACTOR	B801-08-034	
				DOWN CONTACTOR	1	PT-3	B801-08-033	1	DOWN CONTACTOR	B801-08-033	
				UP CONTACTOR	1	PT-4	B801-08-033	1	UP CONTACTOR	B801-08-033	
				ELECTRICAL/MECHANICAL INTERLOCK FOR UP DOWN CONTACTOR	1	PT-5	B801-18-005	1	ELECTRICAL/MECHANICAL INTERLOCK FOR UP DOWN CONTACTOR	B801-18-005	
				MAIN MOTOR OVERLOAD	1	PT-6	B842-43-001	1	MAIN MOTOR OVERLOAD	B842-43-001	MAINS
				MAINS ON INDICATOR LIGHT	1	PT-7	B842-43-002	1	MAINS ON INDICATOR LIGHT	B842-43-002	TEMPERATURE
				TEMPERATURE INDICATOR LIGHT	1	PT-8	B872-22-001	1	TEMPERATURE INDICATOR LIGHT	B872-22-001	
				HEATER CONTACTOR C/BREAKER	1	PT-10	B808-12-001	1	HEATER CONTACTOR C/BREAKER	B808-12-001	
				AUTOMATIC PUSH BUTTON	1	PT-10a-1	B801-12-039	1	AUTOMATIC PUSH BUTTON	B801-12-039	
				CONTACT BLOCK	1	PT-10b-1	B801-14-002	1	CONTACT BLOCK	B801-14-002	
				ADAPTOR KIT	1	PT-10c-1	B801-18-003	1	ADAPTOR KIT	B801-18-003	
				UP LIMIT SWITCH	1	PT-11	B801-11-013	1	UP LIMIT SWITCH	B801-11-013	AUTOMATIC SWITCH
				UP LIMIT SWITCH	1		B801-45-005	1	UP LIMIT SWITCH	B801-45-005	OPERATING HEAD SWITCH
				DOWN LIMIT SWITCH	1	PT-12	B801-11-013	1	DOWN LIMIT SWITCH	B801-11-013	OPERATING HEAD SWITCH
				DOWN LIMIT SWITCH	1		B801-45-006	1	DOWN LIMIT SWITCH	B801-45-006	OPERATING HEAD
				IMMERSION TIMER	1	PT-13	B819-34-004	1	IMMERSION TIMER	B819-34-004	
				MAIN MOTOR CIRCUIT BREAKER	1	PT-14	B872-22-052	1	MAIN MOTOR CIRCUIT BREAKER	B872-22-052	
				HEATER CIRCUIT FUSE	3	PT-15	B823-39-001	3	HEATER CIRCUIT FUSE	B823-39-001	
				HEATER CIRCUIT MCB	3	PT-15	B872-22-008	3	HEATER CIRCUIT MCB	B872-22-008	
				COOKING TEMP THERMOSTAT	1	PT-16	B873-30-002	1	COOKING TEMP THERMOSTAT	B873-30-002	
				EXCESS TEMP THERMOSTAT	1	PT-17	B873-30-001	1	EXCESS TEMP THERMOSTAT	B873-30-001	
				AUTO/MANUAL TOGGLE SWITCH	1	PT-18	B816-07-001	1	AUTO/MANUAL TOGGLE SWITCH	B816-07-001	AUTO/MANUAL
				OFF/UP DOWN/ON TOGGLE SWITCH	1	PT-19	B816-07-006	1	OFF/UP DOWN/ON TOGGLE SWITCH	B816-07-006	OFF/UP ; ON/DOWN
				IMMERSION TIME POTENTIOMETER	1	PT-20	B842-59-007	1	IMMERSION TIME POTENTIOMETER	B842-59-007	0-5 MINS
				IMMERSION ELEMENTS 240V	3	PT-21	B906-04-001	3	IMMERSION ELEMENTS 240V	B906-04-001	
				IMMERSION ELEMENTS 220V	3	PT-21	B906-04-005	3	IMMERSION ELEMENTS 220V	B906-04-005	
				OVERHEAT BUZZER	1	PT-22	B883-92-001	1	OVERHEAT BUZZER	B883-92-001	OVERHEAT
				AMBER LENS	1	PT-23	B801-44-007	1	AMBER LENS	B801-44-007	
				LENS BODY	1	PT-23	B801-43-012	1	LENS BODY	B801-43-012	
				240 VOLT NEON	1	PT-23	B842-94-001	1	240 VOLT NEON	B842-94-001	
				"KILLER" THERMOSTAT	1	PT-24	B873-30-005	1	"KILLER" THERMOSTAT	B873-30-005	
				"KILLER" THERMOSTAT	1	PT-25	B873-30-005	1	"KILLER" THERMOSTAT	B873-30-005	
				"KILLER" THERMOSTAT	1	PT-26	B873-30-005	1	"KILLER" THERMOSTAT	B873-30-005	
				MAIN UP/DOWN MOTOR	1	PT-27	B859-74-009	1	MAIN UP/DOWN MOTOR	B859-74-009	
				3 POLE + N + E 32-45 AMP PLUG	1	PT-28	B814-25-012	1	3 POLE + N + E 32-45 AMP PLUG	B814-25-012	

SWANSEA IND. EST.
FFORESTFACH,
SWANSEA.
SAB 4EB.
TEL: (01782) 581234
FAX: (01782) 561016
E-mail: 100432.509@compuserve.com

MONO
EQUIPMENT
ELECTRICAL SPECIFICATIONS:-
380-415V

TITLE:
AUTOMATIC DOUGHNUT COOKER WITH
"KILLER THERMOSTATS"
COMPONENTS PARTS LIST

DRAWN:
RE-DRAWN
DATE:
24-8-99
6-10-98

ELECTRICALLY APPROVED BY:-
DRAWING NO. SHT 2 of 2
M029E25-02800
REV: D

D	JC	25-06-07	CONTACTORS & D/LOADS B801 WERE B859	3011
C	RAC	24-09-03	SEE ECN's 1948/1949	
B	JC	4-2-99	MARTIN LUNEL PLUG FITTED	09/12
A	PB	1-9-93	ITEMS 11 & 12 WERE B809-11-001	4441
REV	SIG	DATE	REVISION	ECN NO.

COPYRIGHT © 1998 - THIS DESIGN/DRAWING IS THE PROPERTY OF MONO EQUIPMENT LTD. AND MUST NOT BE REPRODUCED, COPIED, NOR ITS CONTENTS DIVULGED WITHOUT PRIOR WRITTEN PERMISSION.

IF IN ANY DOUBT - ASK	PT-REF	QUANTITY	DESCRIPTION	PART No.	LABELLED
	PT-1	1	MAIN ISOLATOR SWITCH	B807-07-007	ON/OFF
	PT-2	1	HEATER CONTACTOR	B801-08-035	
	PT-3/4	1	UP/DOWN CONTACTOR	B801-08-033	
	PT-5	1	ELECTRICAL/MECHANICAL INTERLOCK FOR UP DOWN CONTACTOR	B801-18-005	
	PT-6	1	MAIN MOTOR OVERLOAD	B801-01-043	MAINS
	PT-7	1	MAINS ON INDICATOR LIGHT	B842-43-001	TEMPERATURE
	PT-8	1	TEMPERATURE INDICATOR LIGHT	B842-43-002	
	PT-10	1	HEATER CONTACTOR C/BREAKER	B872-22-001	
UP TO Sept 2003	PT-10	1	AUTOMATIC PUSH BUTTON	B808-12-001	
	PT-10a-1	1	AUTOMATIC PUSH BUTTON	B801-12-039	AUTOMATIC
	PT-10b-1	1	CONTACT BLOCK	B801-14-002	
	PT-10c-1	1	ADAPTOR KIT	B801-18-003	
	PT-11	1	UP LIMIT SWITCH BODY	B801-11-013	
	PT-12	1	UP LIMIT SWITCH ACTUATOR	B801-45-005	
	PT-13	1	DOWN LIMIT SWITCH BODY	B801-11-013	
	PT-14	1	DOWN LIMIT SWITCH ACTUATOR	B801-45-006	
	PT-15	1	IMMERSION TIMER	B819-34-004	
	PT-16	1	MAIN MOTOR CIRCUIT BREAKER	B872-22-052	
	PT-17	3	HEATER CIRCUIT M.C.B.	B872-22-070	
	PT-18	1	COOKING TEMP THERMOSTAT	B873-30-002	
	PT-19	1	EXCESS TEMP THERMOSTAT	B873-30-001	
	PT-20	1	AUTO/MANUAL TOGGLE SWITCH	B816-07-001	AUTO/MANUAL
	PT-21	1	OFF/UP DOWN/ON TOGGLE SWITCH	B816-07-006	OFF/UP ; ON/DOWN
	PT-22	1	IMMERSION TIME POTENTIOMETER	B842-59-007	0-5 MINS
	PT-23	6	IMMERSION ELEMENTS 240V	B906-04-001	
	PT-24	6	IMMERSION ELEMENTS 220V	B906-04-005	
	PT-25	1	OVERHEAT BUZZER	B883-92-001	
	PT-26	1	AMBER LENS	B801-44-007	
	PT-27	1	LENS BODY } OVERHEAT LIGHT	B801-43-012	OVERHEAT
	PT-28	1	MAIN UP/DOWN MOTOR	B859-74-033	

C	RAC	30-01-12	Motor B859-74-033 vbs 009	REV	3011
B	JC	25-06-07	CONTACTORS & O/LOADS B801 WERE B859	REV	
A	RAC	25-09-03	see ech 1948	REV	
REV	SIG	DATE	REVISION	ECN NO.	
 GUESNAP GUESNAP WEST IND PARK SWANSEA SA5 4EB. TEL: (01782) 581234 FAX: (01782) 581018			TITLE: TWIN ELEMENT AUTOMATIC DOUGHNUT COOKER COMPONENTS PARTS LIST		
ELECTRICAL SPECIFICATIONS:-			DRAWN: REDRAWN		
380-415V			JC		
REDRAWN ON CAD 12-98			ELECTRICALLY APPROVED BY:-		
COPYRIGHT © 1998 - THIS DESIGN/DRAWING IS THE PROPERTY OF MONO EQUIPMENT LTD. AND MUST NOT BE REPRODUCED. COPIED. NOR ITS CONTENTS DIVULGED WITHOUT PRIOR WRITTEN PERMISSION.			DRAWING NO. SHT 2 of 2 M049E25-02000		
			REV: C		



12.0 ELECTRICS

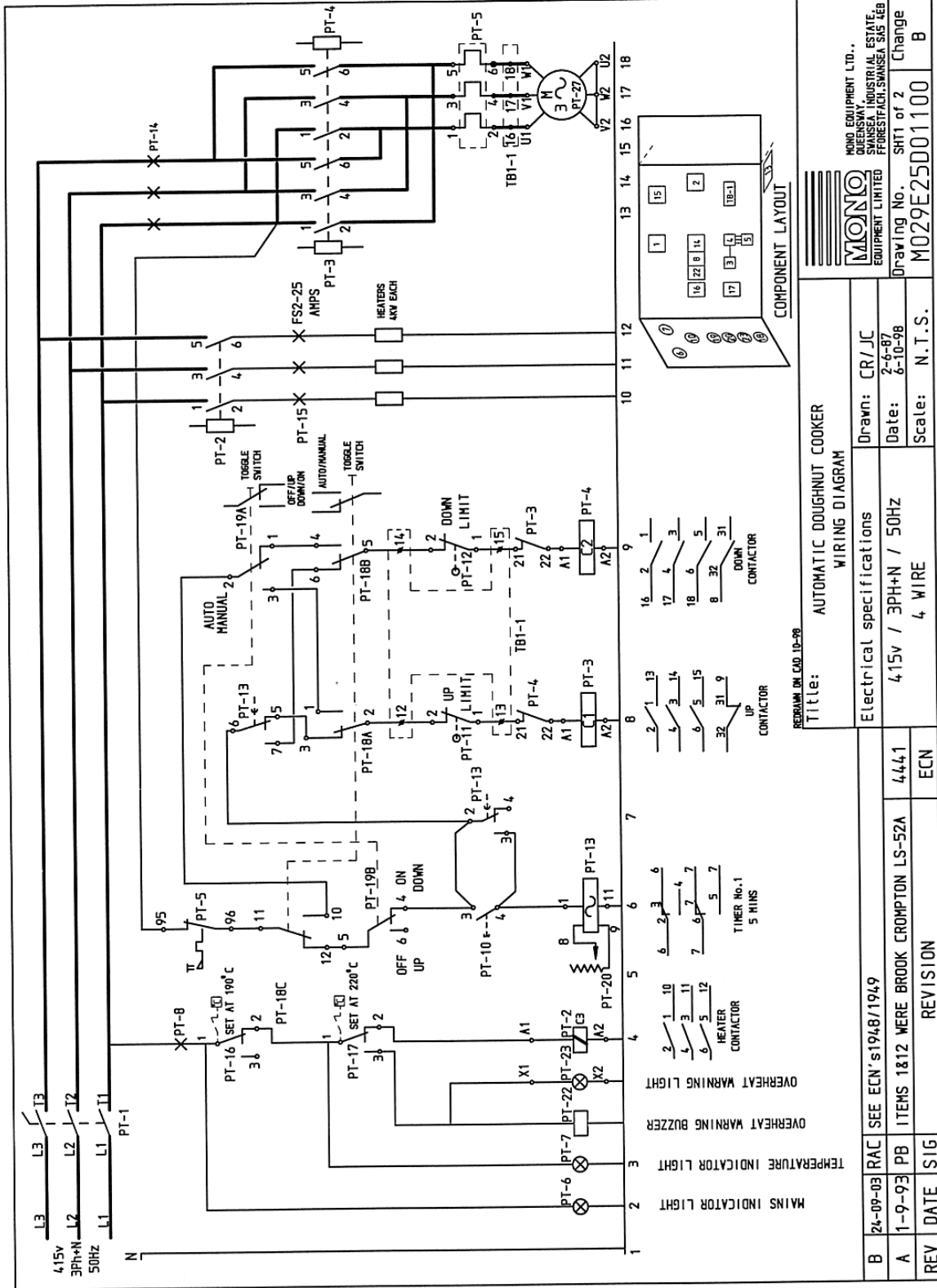

IF IN ANY DOUBT - ASK	PT-REF	QUANTITY	DESCRIPTION	PART No.	LABELLED
	PT-1	1	MAIN ISOLATOR SWITCH	8807-07-007	ON/OFF
	PT-2	1	HEATER CONTACTOR	8801-08-034	
	PT-3 /4	1	UP/DOWN CONTACTOR	8801-08-033	
	PT-5	1	ELECTRICAL/MECHANICAL INTERLOCK FOR UP DOWN CONTACTOR	8801-18-005	
	PT-6	1	MAIN MOTOR OVERLOAD	8801-01-043	MAINS
	PT-7	1	MAINS ON INDICATOR LIGHT	8842-43-001	TEMPERATURE
	PT-8	1	TEMPERATURE INDICATOR LIGHT	8842-43-002	
	PT-10	1	HEATER CONTACTOR C/BREAKER	8872-22-001	
UP TO Sept 2003	PT-10	1	AUTOMATIC PUSH BUTTON	8808-12-001	
	PT-10a-1	1	AUTOMATIC PUSH BUTTON	8801-12-039	AUTOMATIC
	PT-10b-1	1	CONTACT BLOCK	8801-14-002	
	PT-10c-1	1	ADAPTOR KIT	8801-18-003	
	PT-11	1	UP LIMIT SWITCH BODY	8801-11-013	
	PT-12	1	UP LIMIT SWITCH ACTUATOR	8801-45-005	
	PT-13	1	DOWN LIMIT SWITCH BODY	8801-11-013	
	PT-14	1	DOWN LIMIT SWITCH ACTUATOR	8801-45-006	
	PT-15	1	IMMERSION TIMER	8819-34-004	
	PT-16	1	MAIN MOTOR CIRCUIT BREAKER	8872-22-052	
UP TO Sept 2003	PT-15	3	HEATER CIRCUIT FUSE	8823-39-001	
	PT-15	3	HEATER CIRCUIT MCB	8872-22-008	
	PT-16	1	COOKING TEMP THERMOSTAT	8873-30-002	
	PT-17	1	EXCESS TEMP THERMOSTAT	8873-30-001	
	PT-18	1	AUTO/MANUAL TOGGLE SWITCH	8816-07-001	AUTO/MANUAL
	PT-19	1	OFF/UP DOWN/ON TOGGLE SWITCH	8816-07-006	OFF/UP ; ON/DOWN
	PT-20	1	IMMERSION TIME POTENTIOMETER	8842-59-007	0-5 MINS
	PT-21	3	IMMERSION ELEMENTS 240V	B906-04-001	
	PT-21	3	IMMERSION ELEMENTS 220V	B906-04-005	
	PT-22	1	OVERHEAT BUZZER	8883-92-001	
	PT-23	1	AMBER LENS } OVERHEAT LIGHT	8801-44-007	
	PT-23	1	LENS BODY }	8801-43-012	
	PT-27	1	MAIN UP/DOWN MOTOR	8859-74-033	OVERHEAT

D	RAC	30-01-12	Motor	8859-74-033	vs 009	PH-001-12
C	JC	25-06-07	CONTACTORS & O/LOADS	8801 WERE	8859	3011
B	RAC	24-09-03	SEE ECN 's	1948/1949		
A	PB	1-9-93	ITEMS 11 & 12 WERE	8809-11-001		4441
REV	SIG	DATE	REVISION		ECN NO.	
 MONO 1000 SWANSEA WEST IND PARK SWANSEA SA5 4EB. TEL: (01782) 581234 FAX: (01782) 581016						
ELECTRICAL SPECIFICATIONS:-						
380-415V						
TITLE: AUTOMATIC DOUGHNUT COOKER COMPONENTS PARTS LIST						
DRAWN: JC						
REDRAWN: JC						
DATE: 7-9-99						
DRAWING NO. M029E25D01100						
SHT 2 of 2						REV: D

REDRAWN ON CAD 10-98
 COPYRIGHT © 1998 - THIS DESIGN/DRAWING IS THE PROPERTY OF MONO EQUIPMENT LTD. AND MUST NOT BE REPRODUCED, COPIED, NOR ITS CONTENTS DIVULGED WITHOUT PRIOR WRITTEN PERMISSION.

IF IN ANY DOUBT - ASK

PT-REF	QUANTITY	DESCRIPTION	PART No.	LABELLED ON/OFF
PT-1	1	MAIN ISOLATOR SWITCH	B807-07-007	
PT-2	1	HEATER CONTACTOR	B801-08-034	
PT-3	1	DOWN CONTACTOR	B801-08-033	
PT-4	1	UP CONTACTOR	B801-08-033	
	1	ELECTRICAL/MECHANICAL INTERLOCK FOR UP DOWN CONTACTOR	B801-18-005	
PT-5	1	MAIN MOTOR OVERLOAD	B801-01-043	
PT-6	1	MAINS ON INDICATOR LIGHT	B842-43-001	MAINS TEMPERATURE
PT-7	1	TEMPERATURE INDICATOR LIGHT	B842-43-002	
PT-8	1	HEATER CONTACTOR C/BREAKER	B872-22-001	
UP TO Sept 2003	1	AUTOMATIC PUSH BUTTON	B808-12-001	
PT-10a-1	1	AUTOMATIC PUSH BUTTON	B808-12-039	
PT-10b-1	1	CONTACT BLOCK	B808-14-002	
PT-10c-1	1	ADAPTOR KIT	B808-18-003	
PT-11	1	UP LIMIT SWITCH	B801-11-013	
	1	UP LIMIT SWITCH	B801-45-005	AUTOMATIC SWITCH
	1	DOWN LIMIT SWITCH	B801-11-013	OPERATING HEAD SWITCH
	1	DOWN LIMIT SWITCH	B801-45-006	OPERATING HEAD SWITCH
PT-12	1	IMMERSION TIMER	B819-34-004	
PT-13	1	MAIN MOTOR CIRCUIT BREAKER	B872-22-052	
PT-14	1	HEATER CIRCUIT FUSE	B823-39-001	
UP TO Sept 2003	3	HEATER CIRCUIT MCB	B872-22-008	
PT-15	3	COOKING TEMP THERMOSTAT	B873-30-002	
PT-16	1	EXCESS TEMP THERMOSTAT	B873-30-001	
PT-17	1	AUTO/MANUAL TOGGLE SWITCH	B816-07-001	AUTO/MANUAL OFF/UP : ON/DOWN 0-5 MINS
PT-18	1	OFF/UP DOWN/ON TOGGLE SWITCH	B816-07-006	
PT-19	1	IMMERSION TIME POTENTIOMETER	B842-59-007	
PT-20	1	IMMERSION ELEMENTS	B906-04-001	
PT-21	3	OVERHEAT BUZZER	B883-92-001	
PT-22	1	AMBER LENS	B801-44-007	
PT-23	1	LENS BODY	B801-43-012	OVERHEAT
	1	240 VOLT NEON	B842-94-001	
PT-24	1	"KILLER" THERMOSTAT	B873-30-005	
PT-25	1	"KILLER" THERMOSTAT	B873-30-005	
PT-26	1	"KILLER" THERMOSTAT	B873-30-005	
PT-27	1	MAIN UP/DOWN MOTOR	B859-74-009	
PT-28	1	3 POLE + N + E 32-45 AMP PLUG	B814-25-012	

 SWANSEA INDUST. FORESTFACH, SWANSEA, SA5 4EB. TEL: (01782) 561234 FAX: (01782) 561016 Email: 10432.50@compuserve.com		TITLE: AUTOMATIC DOUGHNUT COOKER WITH "KILLER THERMOSTATS" COMPONENTS PARTS LIST	
ELECTRICAL SPECIFICATIONS:-		DRAWN: REDRAWN JC	ELECTRICALLY APPROVED BY:-
REDRAWN ON CAD 10-98		DATE: 24-8-89	DRAWING NO. SHT 2 of 2
		6-10-98	M029E25-02800
			REV: D

D	JC	25-06-07	CONTACTORS & O/LOADS B801 WERE B859	3011
C	RAC	24-09-03	SEE ECN's 1948/1949	
B	JC	4-2-99	MARTIN LUNEL PLUG FITTED	09/12
A	PB	1-9-93	ITEMS 11 & 12 WERE B809-11-001	4441
REV	SIG	DATE	REVISION	ECN NO.
COPYRIGHT © 1998 - THIS DESIGN/DRAWING IS THE PROPERTY OF MONO EQUIPMENT LTD. AND MUST NOT BE REPRODUCED, COPIED, NOR ITS CONTENTS DIVULGED WITHOUT PRIOR WRITTEN PERMISSION.				

IF IN ANY DOUBT - ASK

PT-REF	QUANTITY	DESCRIPTION	PART No.	LABELLED
PT-1	1	MAIN ISOLATOR SWITCH	8807-07-007	ON/OFF
PT-2	1	HEATER CONTACTOR	8801-08-035	
PT-3/4	1	UP/DOWN CONTACTOR	8801-08-033	
PT-5	1	ELECTRICAL/MECHANICAL INTERLOCK FOR UP DOWN CONTACTOR	8801-18-005	
PT-6	1	MAIN MOTOR OVERLOAD	8801-01-043	MAINS
PT-7	1	MAINS ON INDICATOR LIGHT	8842-43-001	TEMPERATURE
PT-8	1	TEMPERATURE INDICATOR LIGHT	8842-43-002	
PT-10	1	HEATER CONTACTOR C/BREAKER	8872-22-001	
PT-10a-1	1	AUTOMATIC PUSH BUTTON	8808-12-001	
PT-10b-1	1	AUTOMATIC PUSH BUTTON	8808-12-039	AUTOMATIC
PT-10c-1	1	CONTACT BLOCK	8808-14-002	
PT-11	1	ADAPTOR KIT	8808-18-003	
PT-12	1	UP LIMIT SWITCH BODY	8801-11-013	
PT-13	1	UP LIMIT SWITCH ACTUATOR	8801-45-005	
PT-14	1	DOWN LIMIT SWITCH BODY	8801-11-013	
PT-15	1	DOWN LIMIT SWITCH ACTUATOR	8801-45-006	
PT-16	1	IMMERSION TIMER	8819-34-004	
PT-17	1	MAIN MOTOR CIRCUIT BREAKER	8872-22-052	
PT-18	3	HEATER CIRCUIT M.C.B.	8872-22-070	
PT-19	1	COOKING TEMP THERMOSTAT	8873-30-002	
PT-20	1	EXCESS TEMP THERMOSTAT	8873-30-001	
PT-21	1	AUTO/MANUAL TOGGLE SWITCH	8816-07-001	AUTO/MANUAL
PT-22	1	OFF/UP DOWN/ON TOGGLE SWITCH	8816-07-006	OFF/UP ; ON/DOWN
PT-23	1	IMMERSION TIME POTENTIOMETER	8842-59-007	0-5 MINS
PT-27	1	IMMERSION ELEMENTS 240V	8906-04-001	
	6	IMMERSION ELEMENTS 220V	8906-04-005	
	1	OVERHEAT BUZZER	8883-92-001	
	1	AMBER LENS	8801-44-007	
	1	LENS BODY	8801-43-012	OVERHEAT
	1	MAIN UP/DOWN MOTOR	8859-74-009	

UP TO Sept 2003

B	JC	25-06-07	CONTACTORS & O/LOADS	8801 WERE	8859	3011
A	RAC	25-09-03	see ecn	1948		
REV	SIG	DATE	REVISION		ECN NO.	
			TITLE: TWIN ELEMENT AUTOMATIC DOUGHNUT COOKER COMPONENTS PARTS LIST			
ELECTRICAL SPECIFICATIONS:-			DRAWN: JC	ELECTRICALLY APPROVED BY:-		
380-4,15V			DRAWING NO. SHI 2 of 2 M049E25-02000			
			REV: B			

REDRAM ON CAD 12-98
 COPYRIGHT © 1998 - THIS DESIGN/DRAWING IS THE PROPERTY OF MONO EQUIPMENT LTD. AND MUST NOT BE REPRODUCED, COPIED, OR ITS CONTENTS DIVULGED WITHOUT PRIOR WRITTEN PERMISSION.

□ **DISPOSAL**

CARE SHOULD BE TAKEN WHEN THE MACHINE COMES TO THE END OF ITS WORKING LIFE. ALL PARTS SHOULD BE DISPOSED OF IN THE APPROPRIATE PLACE, EITHER BY RECYCLING OR OTHER MEANS OF DISPOSAL THAT COMPLIES WITH LOCAL REGULATIONS.

(IN UK, ENVIRONMENTAL PROTECTION ACT 1990 APPLIES)



MONO Equipment

Queensway, Swansea West Industrial Park, Swansea, SA5 4EB UK

Tel. 01792 561234

Email: mono@monoequip.com

www.monoequip.com

As it is our policy to improve our machines continuously, we reserve the right to change specifications without prior notice.