

Enter **Serial No.** here. _____

In the event of an enquiry please quote this serial number.



OMEGA TOUCH

SOFT DOUGH DEPOSITOR

(400, 450, 580)

OPERATING AND MAINTENANCE MANUAL

The use of templates and/or accessories not produced or supplied by MONO Equipment will invalidate the machine's warranty



FILE 35
ENGLISH



Declaration of Compliance (DoC)



Date of Declaration: 24.04.2023

Business Operator	Mono Equipment Queensway Swansea West Industrial Park Swansea, SA5 4EB P (+44) 1792 561234; F (+44) 1792 561016; E cpetherbridge@monoequip.com www.monoequip.com	
Product Family	Mono Confectionery Depositor range, including accessories	
Article/Model numbers	FG085*** FG086*** FG079***	
Description	Confectionery depositor	
Plastic Materials	Nylon PA6 akulon F223D, SABIC Polypropylene PHC 31, TECAFORM AH natural, Iglidur A350 NMG 26-99, PE-500.	
Regulation (EC) No 1935/2004	This product family is intended to come into contact with food and is in compliance with Regulation (EC) No 1935/2004 of the European Parliament and of the Council on materials and articles intended to come into contact with food.	
Commission Regulation (EC) No 2023/2006	This product family is produced according to Commission Regulation (EC) No 2023/2006 of 22 December 2006 on good manufacturing practice for materials and articles intended to come into contact with food (GMP).	
Commission Regulation (EU) No 10/2011	Monomers and intentionally added additives used to manufacture this product family are listed in Annex 1 of Commission Regulation (EU) No 10/2011 of 14 January 2011 on plastic materials and articles intended to come into contact with food. Subsequent amendments up to (EU) 2020/1245 are included. Monomers and/or additives with specific migration level (SML) are used. The substances with a SML will not migrate in quantities that exceed the SML, under the specified conditions of use. Upon request Mono Equipment will supply relevant information regarding these substances on a confidential basis.	
Dual use additives	This product family contains no articles intended to come into contact with food containing dual-use additives.	
Functional Barrier	This product family contains no multi-layer materials or articles intended to come into contact with food with a functional barrier.	
Migration analysis	Samples of the product, or a similar product made from identical plastic material, have been tested for overall migration according to the test conditions specified in Commission Regulation (EU) No 10/2011, and the articles comply with the overall migration limit of 10mg/dm ² or 60mg/kg.	
Max ratio of food contact surface area to volume	2.0 dm ² /100 ml	
General	Articles intended to come into contact with food should be cleaned, disinfected, and sterilised, as appropriate to its intended use, before use.	
Date	24.04.2023	
Sign	 C N Petherbridge Quality & Compliance Manager	 Alex Davies Engineering Manager



DECLARATION OF CONFORMITY

We hereby declare that this machine complies with the essential health and safety requirements of:

- The Machinery Directive 2006/42/EC
- The Low Voltage Directive 2014/35/EC
- The requirements of the Electromagnetic Compatibility Directive 2014/30/EU incorporating standards
 - o EN 55014-1:2017/A11:2020
 - o EN 55014-2:1997+A1:2001+A2:2008
- The General Safety of Machinery and food processing Standards applicable
- Materials and Articles intended to come into contact with food - Regulation (EC) No.1935/2004
- Good manufacturing practice for materials intended to come in to contact with food – Regulation (EC) No.2023/2006

Signed			
	Craig Petherbridge – Quality Manager		
Date			
Machine FG Code.		Machine Serial No.	

A technical construction file for this machine is retained at the following address:

MONO EQUIPMENT

Queensway,
Swansea West Industrial Park,
Swansea
SA5 4EB
UK

MONO EQUIPMENT is a business name of **AFE GROUP Ltd**
Registered in England No.3872673 VAT registration No.923428136

Registered Office:
Unit 35, Bryggen Road,
North Lynn Industrial Estate,
Kings Lynn
Norfolk
PE30 2HZ
UK

QD 001

Dated 22/07/2022

Failure to adhere to the cleaning and maintenance instructions detailed in this booklet could affect the warranty of this machine.



The use of templates and/or accessories not produced or supplied by MONO Equipment will invalidate the machine's warranty

SAFETY SYMBOLS

The following safety symbols are seen throughout this manual (available at www.monoequip.com). Before using your new equipment, read the instruction manual carefully and pay special attention to information marked with the following symbols



WARNING Indicates a hazardous situation which, if not avoided, could result in death or severe injury.



WARNING Indicates a hazardous situation which, if not avoided, could result in death or severe injury.



CAUTION Indicates a hazardous situation which, if not avoided, could result in minor or moderate injury.



ELECTRICAL SAFETY AND ADVICE REGARDING SUPPLEMENTARY ELECTRICAL PROTECTION

Commercial bakeries, kitchens and food service areas are environments where electrical appliances may be located close to liquids, or operate in and around damp conditions, or where restricted movement for installation and service is evident.

The installation and periodic inspection of the appliance should only be undertaken by a qualified, skilled and competent electrician, and connected to the correct supply suitable for the load as stipulated by the appliance data label.

The electrical installation and connections should meet the necessary requirements of the local electrical wiring regulations and any electrical safety guidelines.

We Recommend:

- Supplementary electrical protection with the use of a residual current device (RCD)
- Fixed wiring appliances incorporate a locally situated switch disconnector to connect to, which is easily accessible for switching off and safe isolation purposes. The switch disconnector must meet the specification requirements of IEC 60947.

Your attention is drawn to:

BS 7671:2018 – Guidance Note 8 – 8.13 : Other locations of increased risk

It is recognised that there may be locations of increased risk of electrical shock other than those specifically addressed in Part 7 of BS 7671. Examples of such locations could include laundries where there are washing and drying machines in close proximity, and water is present, and commercial kitchens with stainless steel units, where once again, water is present. Where, because of the perception of additional risks being likely, the installation designer decides that an installation or location warrants further protective measures, the options available includes:

- Automatic Disconnection of Supply (ADS) by means of a residual current device having a residual operating current not exceeding 30 mA;
- Supplementary protective equipotential bonding; and
- Reduction of maximum fault clearance time.

The provision of RCDs and supplementary bonding must be specified by the host organisation's appointed installation designer or electrical contractor and installed by a suitably qualified and competent electrician so as to comply with Regulations 419.2 and 544.2.



The supply to this machine must be protected by a **30mA Type A RCD**

- 1.0 - INTRODUCTION
- 2.0 - DIMENSIONS
- 3.0 - SPECIFICATIONS
- 4.0 - SAFETY
- 5.0 - INSTALLATION
- 6.0 - ISOLATION
- 7.0 - CLEANING INSTRUCTIONS
- 8.0 - OPERATING CONDITIONS
- 9.0 - PREPARING FOR OPERATION
 - 9A – FITTING THE HOPPER
 - 9B – FITTING A TEMPLATE
- 10.0 - OPERATING INSTRUCTIONS
 - 1** – SELECT PRODUCT TYPE
 - 2** – SELECT SAVED NAME OF PRODUCT TYPE
 - 3** – CONFIRM SETUP
 - 4** – OPERATOR SCREEN
 - 5** – EDIT SCREEN
 - 5A** – TRAY SETUP
 - 6** – COPY
 - 7** – DELETE
 - 8** – PASSWORDS
 - 9** – ENGINEERING SETTINGS
 - 10** – FAULT INFORMATION SCREENS
 - 11** – DEVICE MANAGEMENT (BACKUP/UPDATE/RESTORE)
- 11.0 - MAINTENANCE
- 12.0 - SPARES AND SERVICE
- 13.0 - SPARES LIST
- 14.0 - ELECTRICAL INFORMATION
 - Battery Replacement Procedure (M251 Motion Controller)

1.0 INTRODUCTION

- The innovative “four axis deposit” design of MONO’s “**Omega Touch**” depositor allows it to recreate most of the hand movements of the Master confectioner. This makes the “**Omega Touch**” capable of exceptional accuracy of product weight, size and shape.
- Maintenance is kept to a minimum and the smooth body design makes daily cleaning quick and easy.
- Easy-to-use computer software gives access to 550 recipe programs, which are stored in the memory and easily recalled for use or modification. Recipes and settings can also be backed-up to, and restored from, a USB memory stick (pen drive). The Omega machine can also be updated with new software on a USB memory stick.
Control is via a colour touch screen with graphically represented products already installed that can be created or edited to the required product.
- It is available with soft dough hoppers. There is also a large selection of templates and nozzles.



As it is our policy to improve our machines continuously, we reserve the right to change specifications without prior notice.

2.0 DIMENSIONS

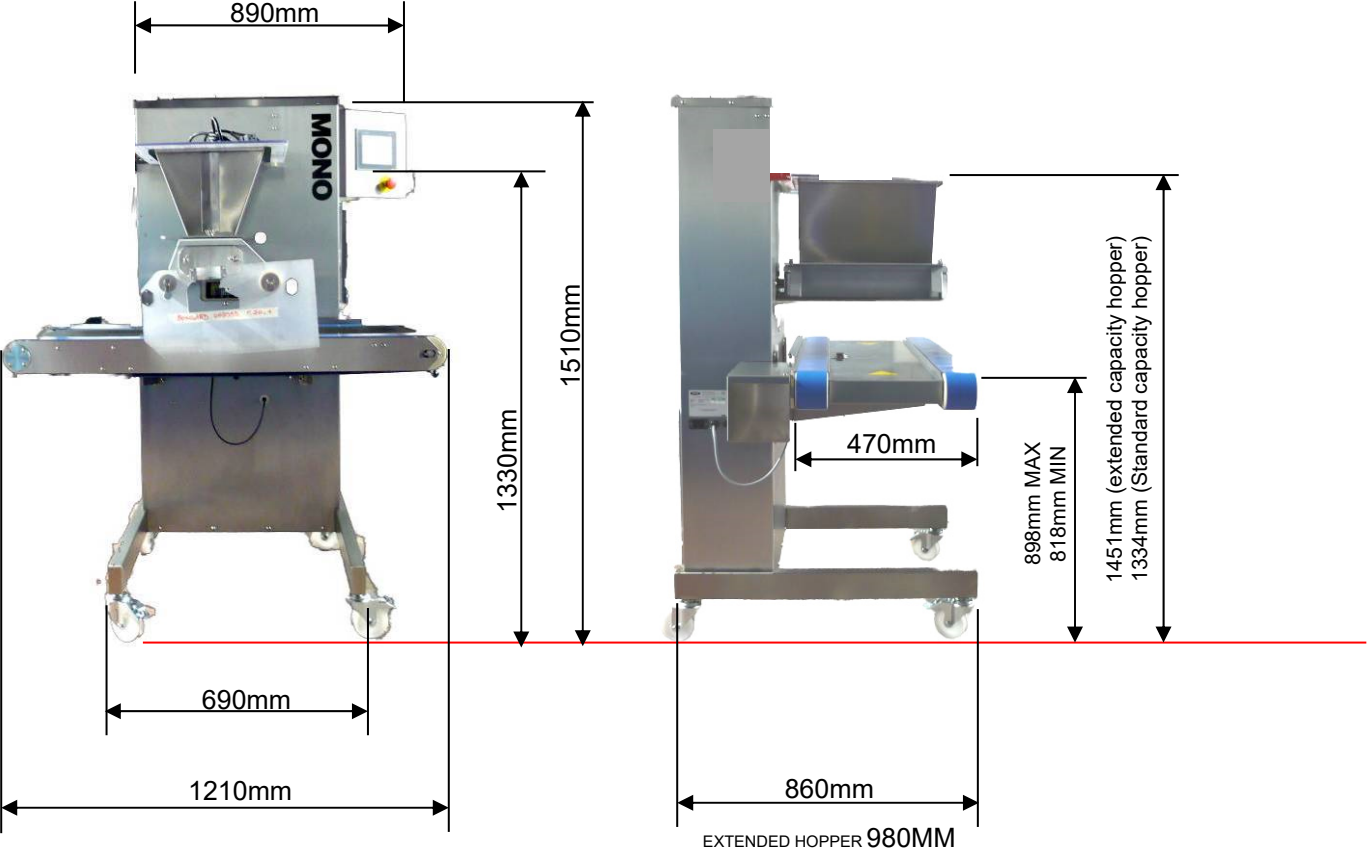

3.0 SPECIFICATIONS

SOFT DOUGH

MODEL (Nom. hopper width (mm))	400	450	580
Weight (with hopper fitted) (Kg):	176	185	194
Standard hopper Capacity (litre) :	20	22.5	29
Extended hopper Capacity (litre) :	36	41	53

Power: Single phase, 13A max load. Suitable for 200v, 220v, 230v, and 240v, 50-60 Hz supply.



The supply to this machine must be protected by a **30mA Type A RCD**

MAX RATING	2.5kW single phase fused at 13A	
Cycles per minute	=	Up to 35
Min distance between trays	=	50mm
Max vertical travel	=	80mm
Max program storage	=	650
Number of languages	=	18
Noise level	=	Less than 85dB
Electronics	=	All microprocessor controlled

NOTE:

The minimum deposit that can be made depends on several factors - recipe, mixing method, template size, nozzle size and deposit speed.

As a guide the following is the minimum that should be attempted:

Macaroons	6g,
Meringues	3g,
Choux Paste	5g,
Viennese	4g,
Sponge Drops	4g.

However, consult **Mono Equipment** if intended product falls outside the above general machine specification to determine the exact capabilities of the "Omega" with any specific product.

As it is our policy to improve our machines continuously, we reserve the right to change specifications without prior notice

1 **Never use a machine in a faulty condition** and always report any damage.

2 **Only trained engineers** may remove parts that need a tool to remove them.

3 Always ensure hands are dry before touching any electrical appliance (including cable, switch and plug). **NEVER move machinery by pulling on the power cords or cables.**



4 **Ensure that the floor area around the OMEGA is clean to avoid slipping** – especially if carrying heavy hopper and template components to and from the machine.

5 **All operatives must be fully trained.**

Use of the machine can prove dangerous if:



- the machine is operated by **untrained or unskilled staff**
- the machine is not used for its **intended purpose**
- the machine is **not operated correctly**

All safety devices applied to the machine during manufacture and the operating instructions in this manual are required to operate this machine safely. The owner and the operator are responsible for operating this machine safely.

6 People undergoing training on the machine must be under **direct supervision**.

7 **Do not operate the machine with any panels or guards removed.**



They are there to protect you.

8 **No loose clothing** or jewellery should be worn while operating the machine.



They could cause damage to the machine and person.

9 **Switch off power** at the mains isolator when machine is not in use and **before** carrying out any **cleaning** or **maintenance**.

- 10 The bakery manager or the bakery supervisor should carry out **daily safety checks** on the machine.



- 11 Do not operate machine without hopper **template and guard fitted correctly**.

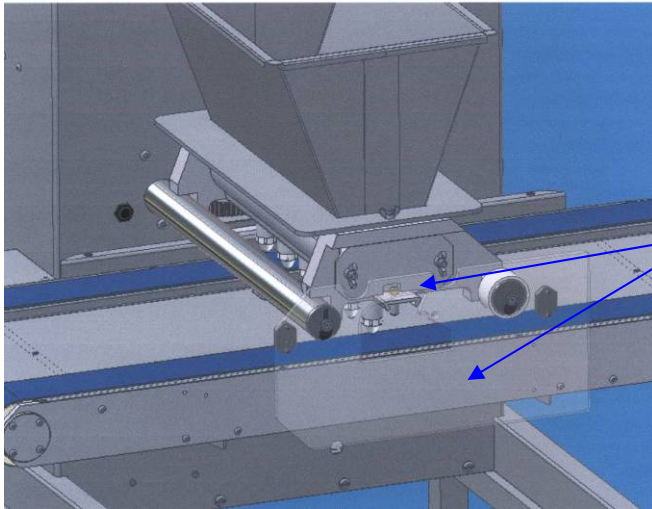

**(11) HOPPER TEMPLATE AND
GUARD FITTED**

NOTE
Guard can be plastic or metal depending
on the machine model



! Due to the essential requirement for handling heavy components during cleaning, it is commended that **protective footwear** be worn when carrying out such procedures.

**ALL CLEANING AND MAINTENANCE OPERATIONS MUST
BE MADE WITH MACHINE DISCONNECTED FROM THE
POWER SUPPLY.**



5.0 INSTALLATION

- 1 Ensure that the depositor is connected to correct electric supply as specified on the serial number plate on the side of the machine.



The supply to this machine must be protected by a **30mA Type A RCD**

- 2 Ensure that the correct fuse rating is fitted in the electrical supply.
3. Position the machine in the correct position for working and lock the two locking wheels to stop movement.

6.0 ISOLATION



IN AN EMERGENCY, SWITCH OFF AT THE ELECTRICAL MAINS WALL ISOLATOR, OR PUSH THE EMERGENCY STOP BUTTON.

To release the emergency stop button, turn clockwise.



STOP BUTTON

NOTE:



- Cleaning must be carried out by fully trained personnel only.
- Isolate machine from mains supply before carrying out any cleaning.
- Do not steam clean or use a jet of water.

-Do not use any form of caustic detergent or abrasive cleaners.-

All the outer surfaces of the machine should be wiped over daily with warm soapy water.

CLEANING SOFT DOUGH HOPPERS

The feed hopper, pump assembly, template, nozzles etc. should be removed from the machine and dismantled for thorough cleaning between product mix changes.

1. Open top safety guard and remove excess mixture remaining in the feed hopper.
2. Lift off front safety cover and locking-ring.

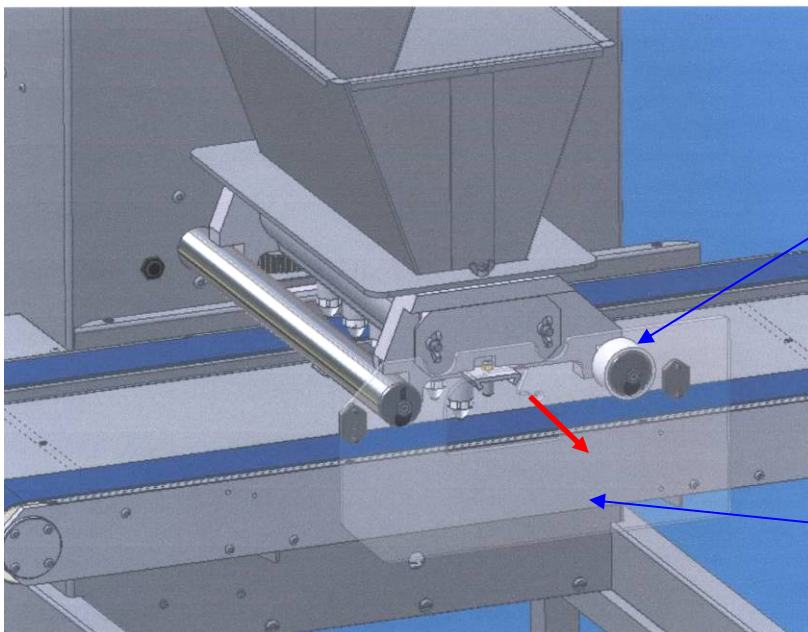

LOCKING RING

SAFETY COVER

NOTE

Cover can be plastic or metal depending on the machine model

3. Slacken template clamp strip nuts or thumbscrews (depending on type of hopper). Remove fitted template from pump assembly by sliding out to avoid subsequent damage.

NOTE.

Thumbscrews only need to be released slightly to allow the template to slide away from the pump assembly. If loosened too much, the template will have to be supported.

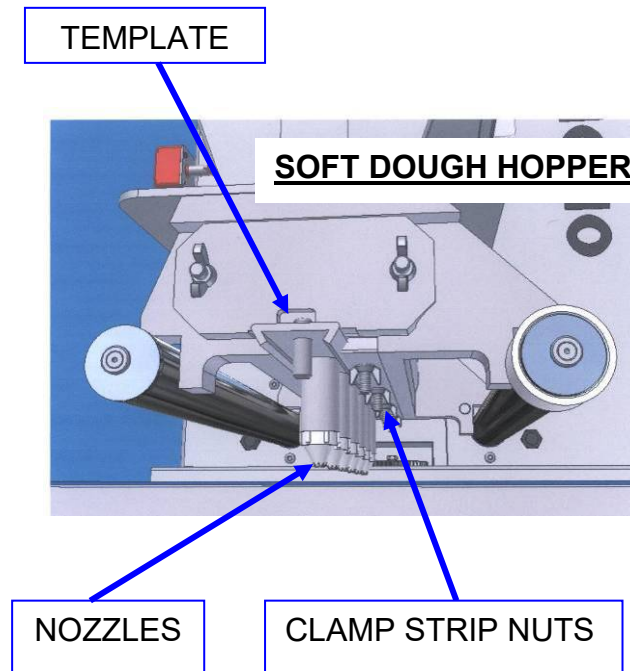

- 4 To reduce weight and bulk, separate and remove empty feed hopper from pump assembly whilst still on the machine by unscrewing the wing nuts.

To gain access to the inner wing nut, slide the complete hopper away from the machine body slightly (keep on support bars) - this will also disengage the pump assembly from the drive shaft.

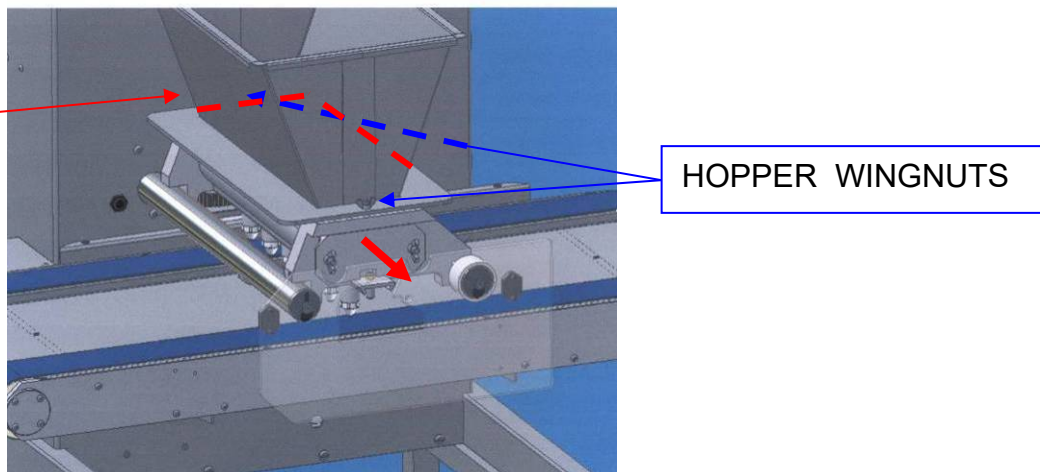

Ensure that the nuts are placed where they will not be lost.



CAUTION:

The feed hopper and pump assembly exceeds 25kg and will need to be lifted off by two people, or dismantled into smaller components while still on the machine.

Take care to avoid damage to the sealing surface of the feed hopper during removal, cleaning, assembly and storage.

5. After removing the feed hopper, check condition of feed hopper seal.

6. Unscrew the end cap retaining nuts from the accessible side of the pump assembly.
(Ensure that the nuts are placed where they will not be lost).

FEED HOPPER
SEALING SURFACE

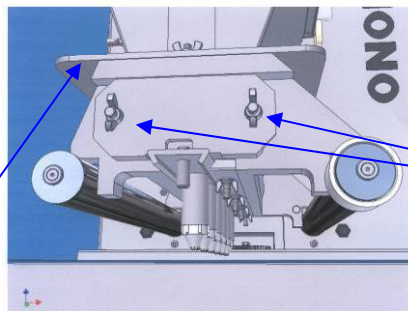

ENDCAP NUTS

7. Withdraw the end-cap with the pump gears.

Ensure that the 'O' sealing ring on the inside of the end-cap is not damaged during cleaning.

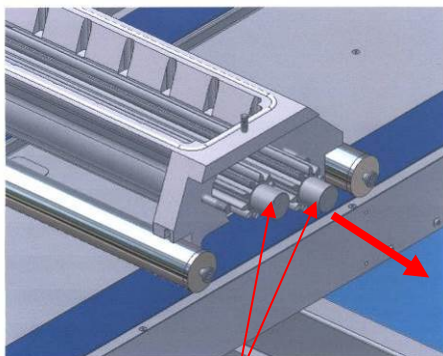

PUMP GEARS
REMOVE WITH END CAP
(NOT SHOWN)

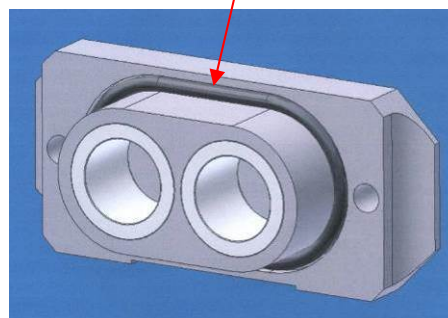

'O' RING IN GROOVE

END CAP

4. Remove remainder of pump assembly from the machine and remove remaining end-cap to fully dismantle pump assembly components for cleaning.

8.0 OPERATING CONDITIONS

To obtain the best product results and consistent operation,

- ✓ Make sure the depositor is used on a **level floor**.
- ✓ Ensure **flat trays** of consistent length, width, material and edge dimensions are used.
- ✓ Ensure **undamaged** nozzles and templates are used.
- ✓ Keep the machine **clean**.



9.0 PREPARING FOR OPERATION

The use of templates and/or accessories not produced or supplied by MONO Equipment will invalidate the machine's warranty

- 1 Select template and nozzles required and fit as section 9a & 9b following.
Fill hopper with mix and close hopper cover.

It is recommended that when heavy mixes are used, the inside of the hopper should be coated with vegetable oil; for lighter mixes such as meringue, dampen with water. The oil or water will help the mix to settle down the hopper walls and prevent air being sucked in.

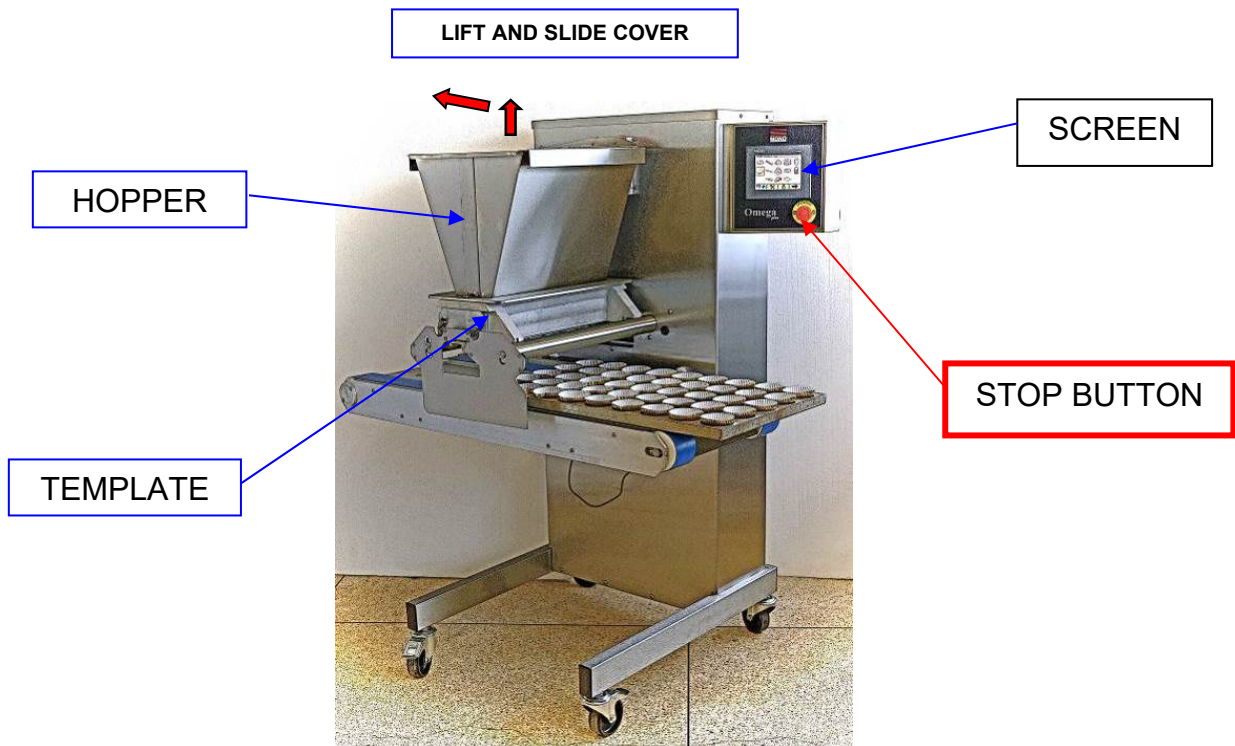

- 2 Connect power cable to electrical supply.
Make sure stop button is in released position (turn clockwise if required).
- 3 Select an existing program or create a new program through the on-screen menus.
(see section 10 operation)
- 4 The machine is now ready for operation.

9a FITTING THE HOPPER



CAUTION SHOULD BE TAKEN WHEN FITTING HOPPER AND PUMP ASSEMBLY, AS WEIGHT EXCEEDS 25KGS ON SOME MODELS. It will need to be lifted on by two people, or dismantled into smaller components before fitting on the machine. MAKE SURE FLOOR AREA AROUND MACHINE IS CLEAN



To reduce weight and bulk fit the complete hopper assembly in two stages - first the pump assembly onto the support bars, then the feed hopper body onto the pump assembly.

- 1 By hand, align pump assembly drive gear roller with drive shaft on machine.
- 2 Fit hopper to pump assembly and secure with wing nuts.
- 3 Slide hopper on support bars until fully up against machine.

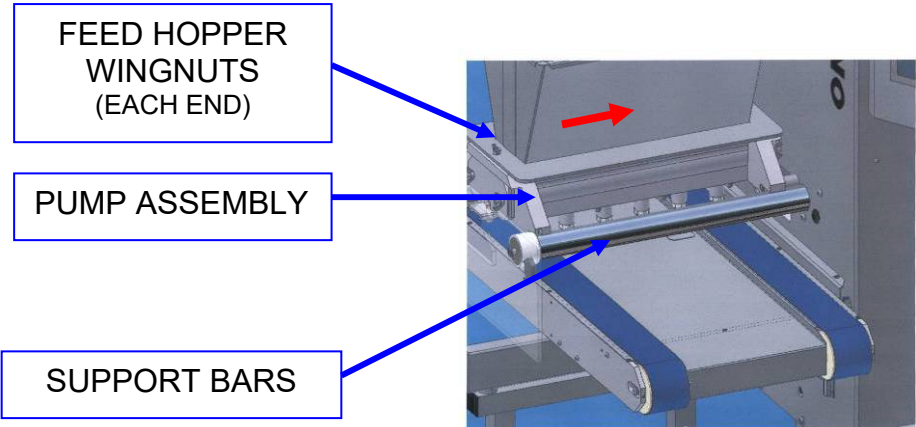

SOFT DOUGH

- 4 After the hopper is fitted, the hopper-locking ring **MUST BE** replaced on the support bar and safety cover replaced with the reflectors facing towards machine body. (The machine will not work without the cover in place).

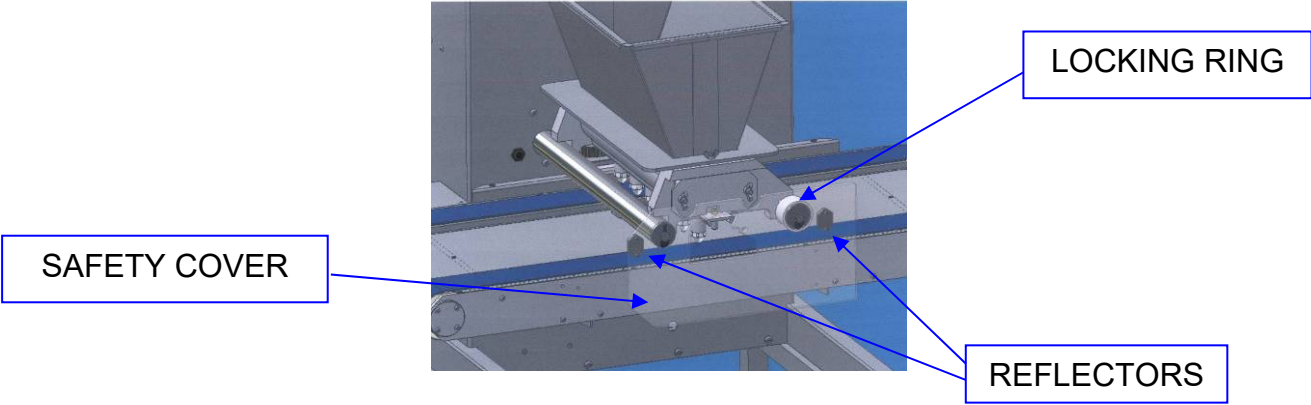

DO NOT OPERATE MACHINE WITHOUT TEMPLATE FITTED

BEFORE USING STRAIGHT & OFFSET NOZZLE HOLDERS **“O” RINGS MUST BE FITTED**

Nozzle holders provide the means of attaching standard plastic nozzles to the soft dough rotary templates and the sealing rings need to be fitted before using and may need replacing occasionally to ensure correct operation.

“O” RING PART NUMBER = A900-12-010 (SUPPLIED IN BAGS OF 20)



LOOP FIRST RING OVER END



SLIDE RING DOWN TO GROOVE



FIRST RING IN CORRECT POSITION



LOOP SECOND RING OVER END



SLIDE RING DOWN TO SECOND GROOVE,
PASSING OVER FIRST RING



SECOND RING IN CORRECT POSITION

9b FITTING A TEMPLATE

- **Soft dough**

Non-rotary templates that can be fitted with nozzles, requires screwing the nozzles into the threaded holes provided.

Rotary templates can have plastic nozzles screwed into nozzle holders (straight or offset).

OR

Metal nozzles secured in place by a separate nut.

- 1 Select template and nozzles required.
(Nozzles are not required for sheeting, staggered or stub templates)
- 2 Attach nozzles to template body:

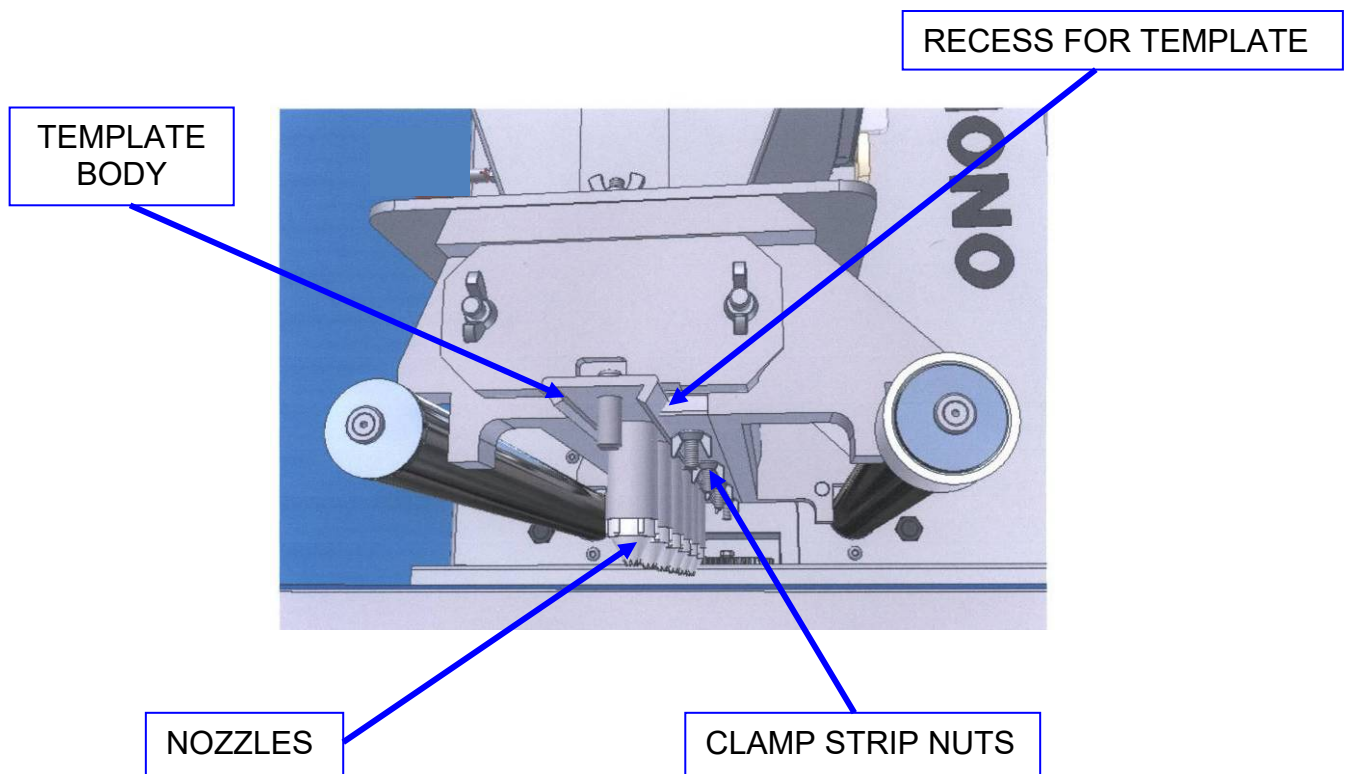

- 3 Slide template into matching recess at base of pump assembly until the stop is in position.
- 4 Tighten nuts on clamp strip (on underside of pump assembly) to secure template.

NOTE. *If the nuts are not securely tightened, leakage of mix will occur, affecting deposit weights.*



DO NOT OPERATE MACHINE WITHOUT TEMPLATE FITTED

10.0 'OMEGA TOUCH' OPERATION

Omega Touch

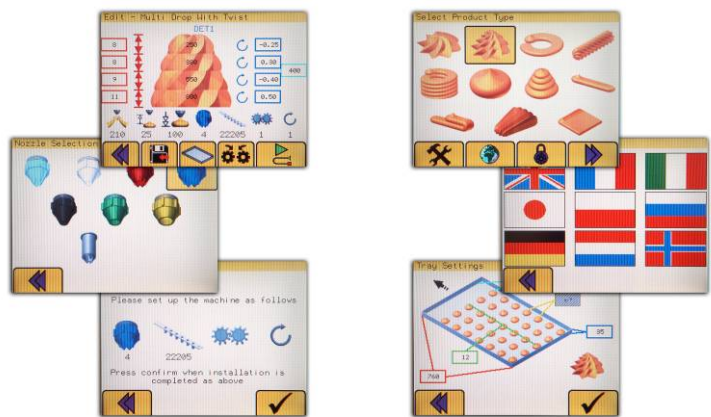

ALL OPERATIONS ARE ACTIVATED BY TOUCHING AREAS ON THE SCREEN WITH A FINGER. DO NOT USE EXCESSIVE FORCE OR HARD OBJECTS AS THIS WILL INVALIDATE MACHINE WARRANTY.

OPERATING KEY

FOR FOLLOWING INSTRUCTIONS

BLUE = OPERATION FOLLOW BLUE ARROWS AND BOXES TO OPERATE THE DEPOSITOR WITH ALREADY SAVED PROGRAMS

RED = CHANGE SETTINGS FOLLOW RED ARROWS AND BOXES TO CHANGE SETTINGS AND CREATE NEW PROGRAMS

 **= KEYBOARD ENTRY REQUIRED** WHEN KEYBOARD APPEARS, A CODE MUST BE ENTERED BY TOUCHING THE NUMBERS IN THE CORRECT ORDER

IF A GREY BOX IS SHOWN IN THE BUTTON DESCRIPTION
 e.g. 7 GO TO THE CORRESPONDING PAGE FURTHER ON IN THE INSTRUCTIONS.
 (MARKED IN TOP RIGHT HAND CORNER OF EACH PAGE)

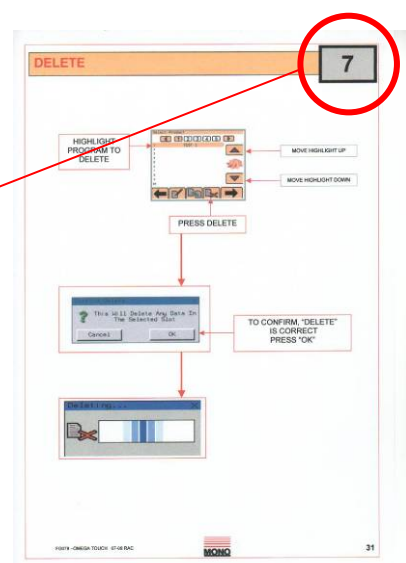
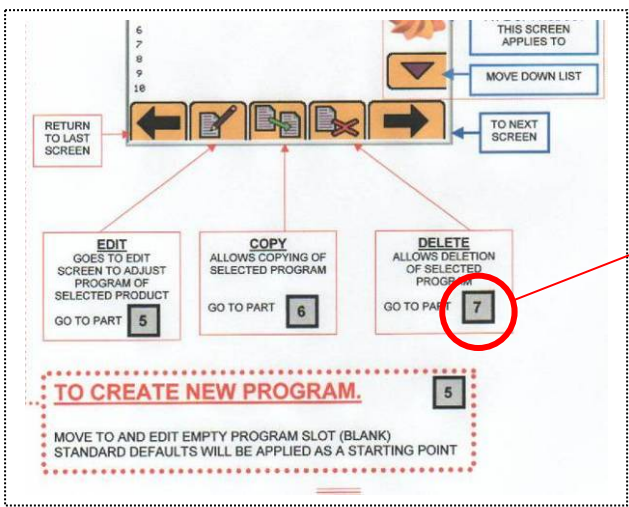

SELECT PRODUCT TYPE

SELECT PRODUCT TO DEPOSIT OR TO CREATE NEW PROGRAM

1

ALL OPERATIONS ARE ACTIVATED BY TOUCHING AREAS ON THE SCREEN WITH A FINGER.
DO NOT USE EXCESSIVE FORCE OR HARD OBJECTS AS THIS WILL INVALIDATE MACHINE WARRANTY.

TOUCH THE SCREEN FOR THE TYPE OF PRODUCT REQUIRED THEN → TO MOVE TO NEXT SCREEN

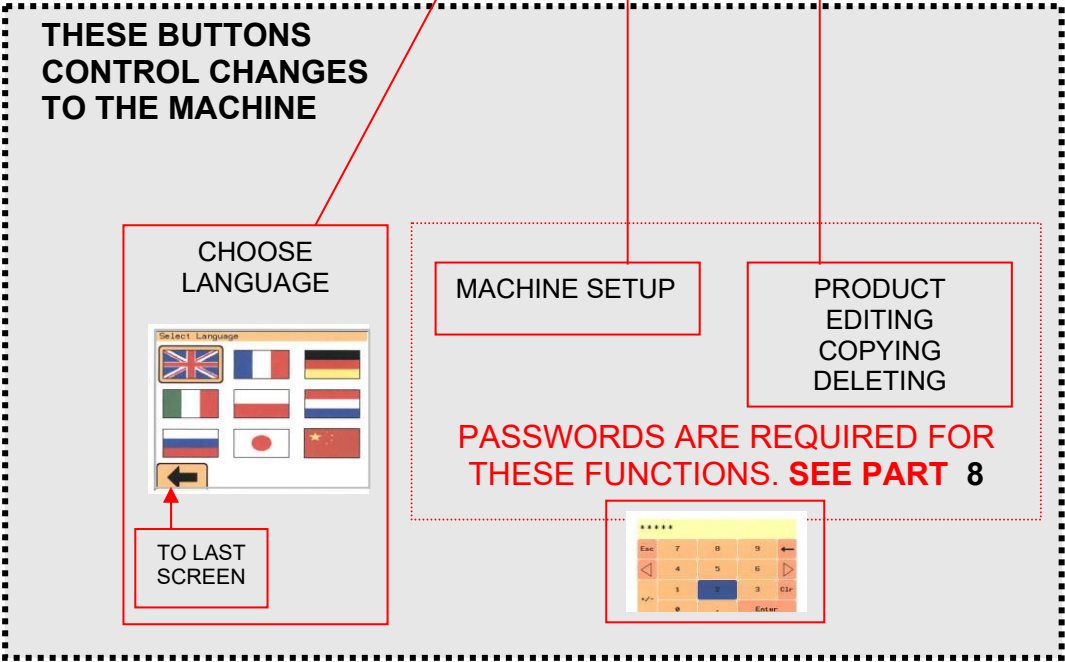
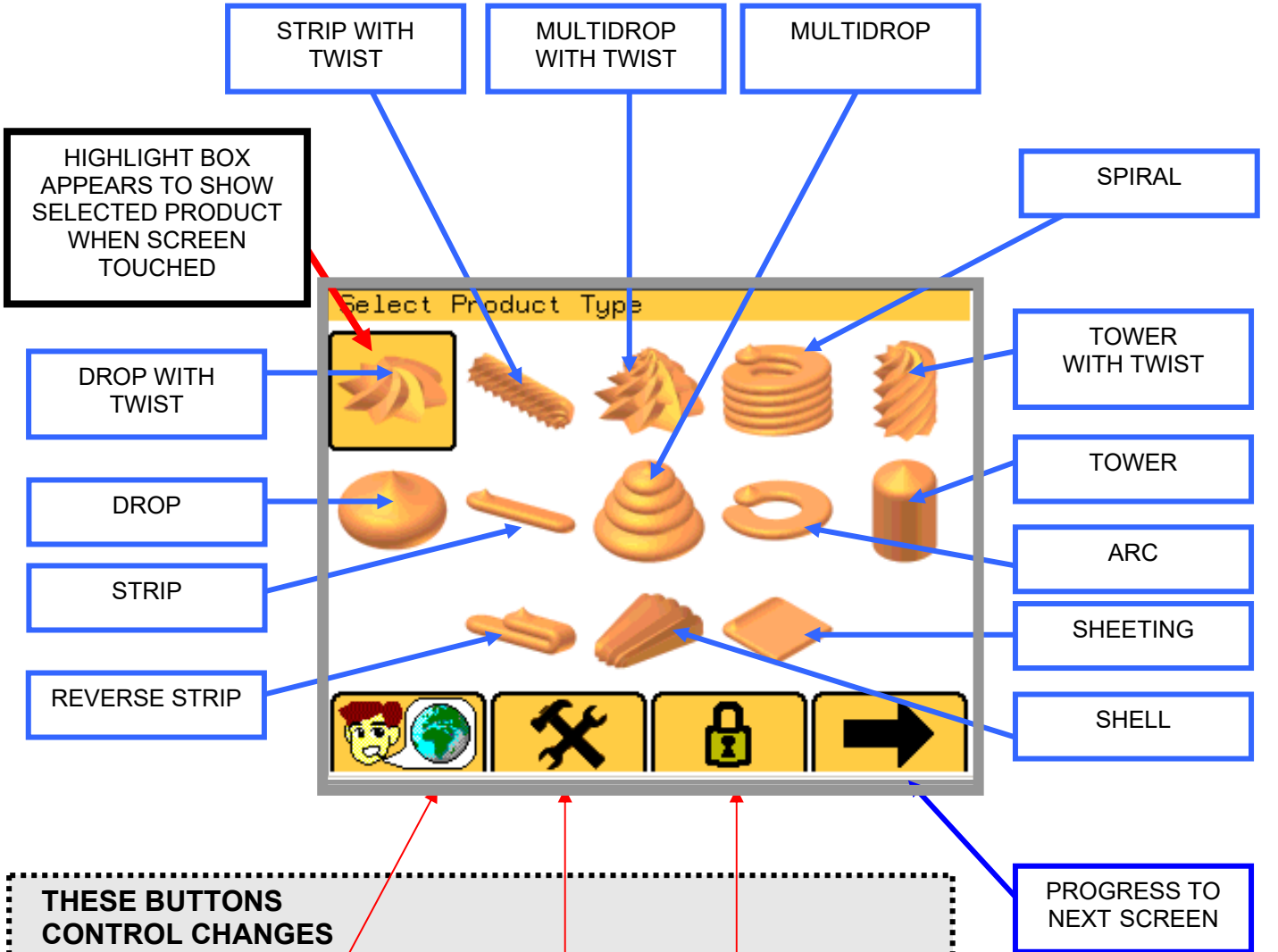

SELECT SAVED PRODUCT TYPE

OR CHOOSE EMPTY SLOT TO CREATE A NEW PROGRAM

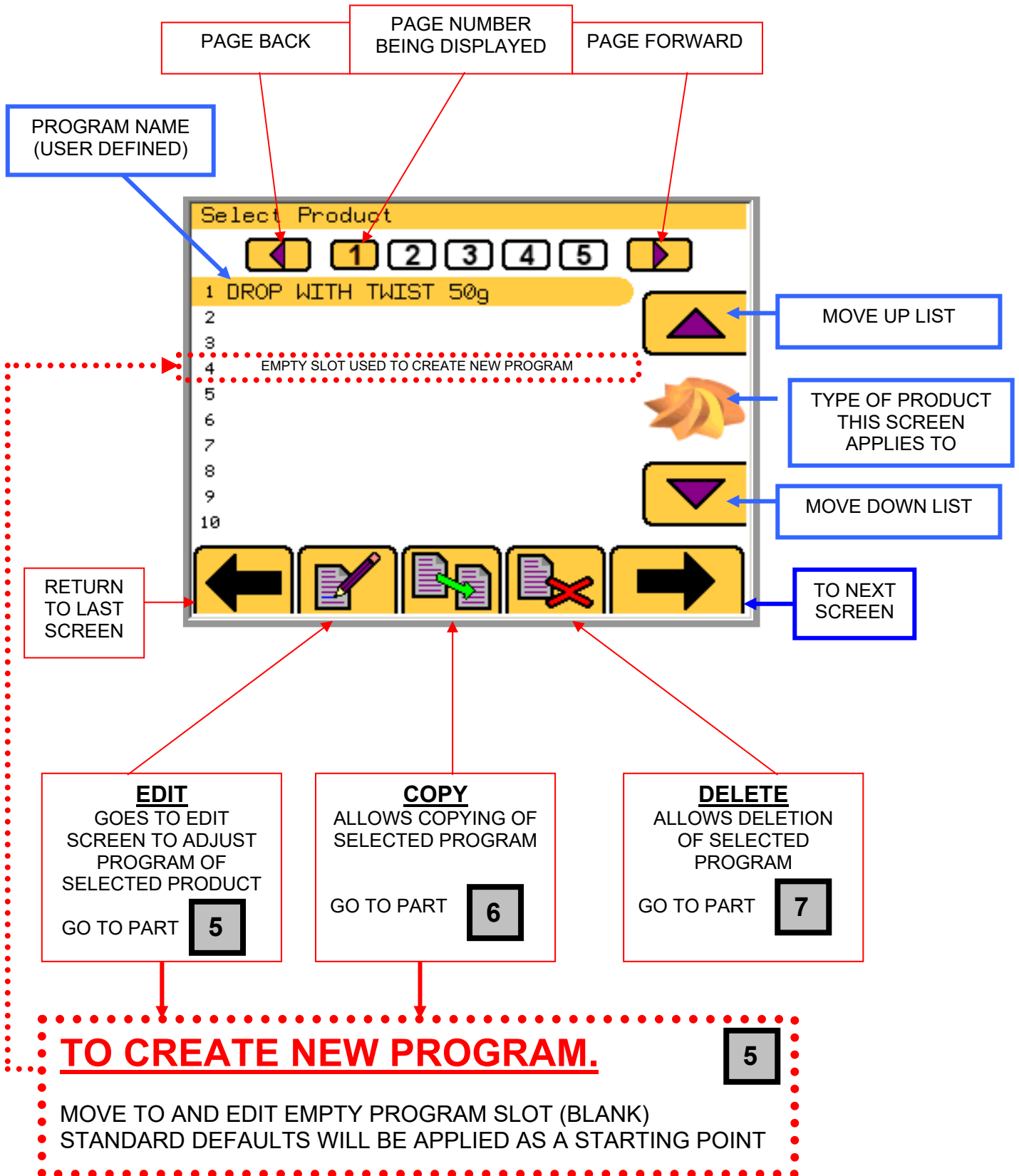

CONFIRM SETUP OF MACHINE

MACHINE MUST BE SET AS SHOWN ON THE SCREEN.
THEN PRESS CONFIRM BUTTON.

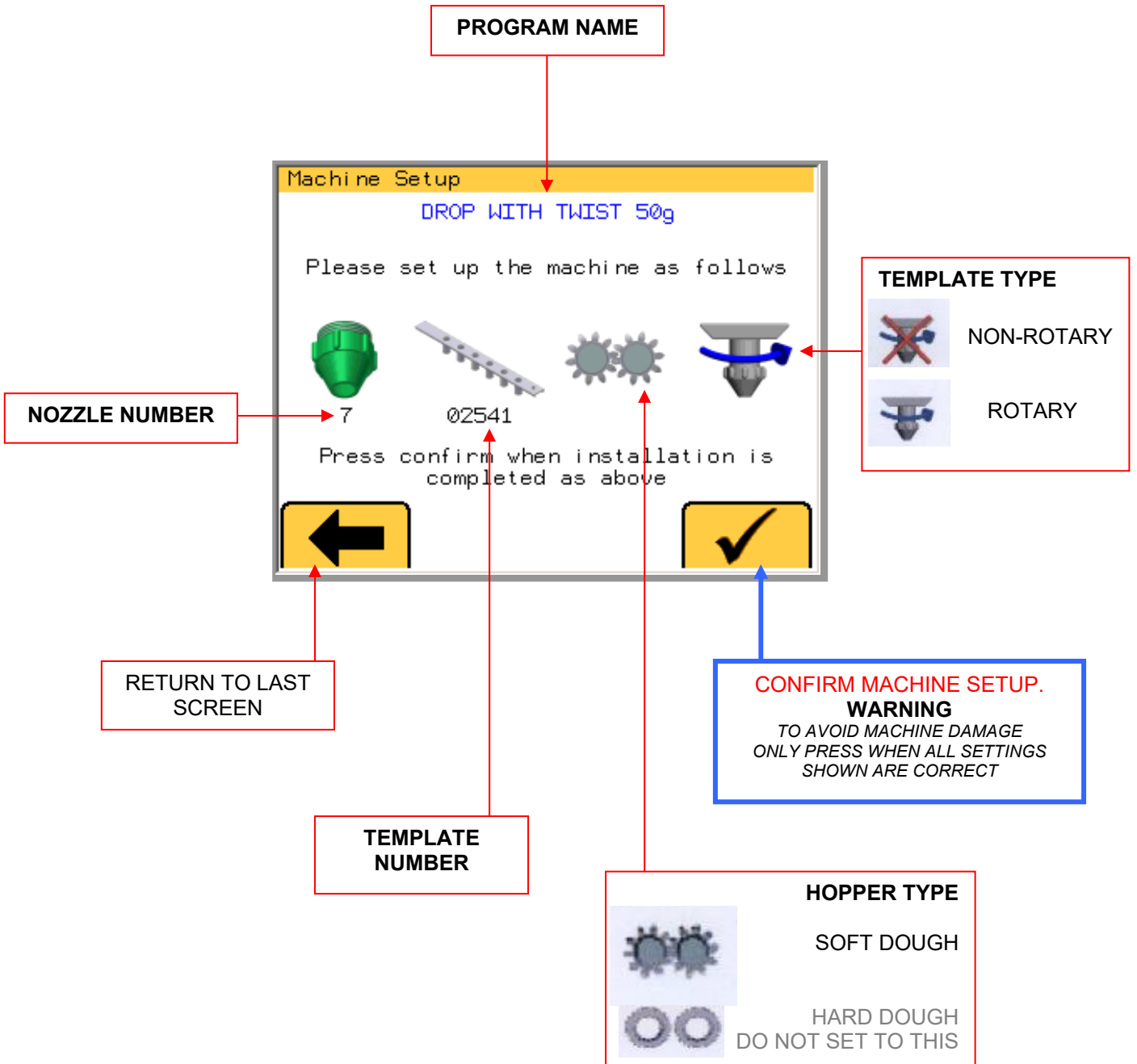

TO AVOID MACHINE DAMAGE
ONLY PRESS CONFIRM BUTTON WHEN ALL PARTS ATTACHED TO THE MACHINE
ARE AS SHOWN ON THE SCREEN

OPERATOR SCREEN

MACHINE IS SET AS SHOWN ON THE SCREEN.
THIS SCREEN CONTROLS THE ACTIONS REQUIRED BY THE OPERATOR.

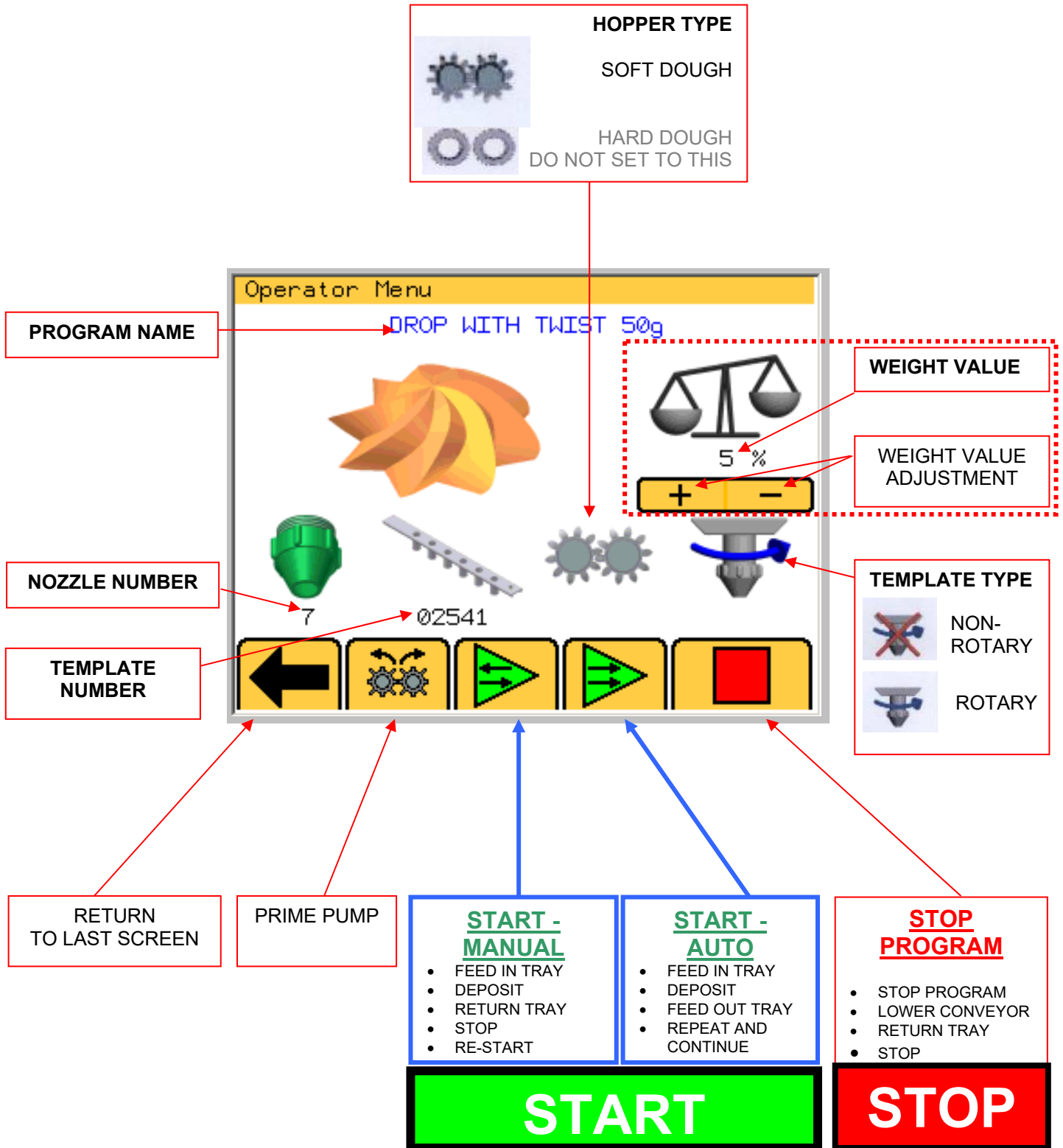

EDIT AND SAVE SCREEN

**EXAMPLE:
DROP WITH
TWIST**

PROGRAM NAME
MUST BE ENTERED TO
ALLOW PROGRAM TO SAVE

PRODUCT QUANTITY
THIS IS A SETTING NUMBER AND
DOES NOT INDICATE A MEASURE OF
ACTUAL VOLUME

NOZZLE HEIGHT (mm)
ABOVE TRAY SURFACE

NOZZLE ROTATIONS
NUMBER OF TURNS
DURING A DEPOSIT CYCLE

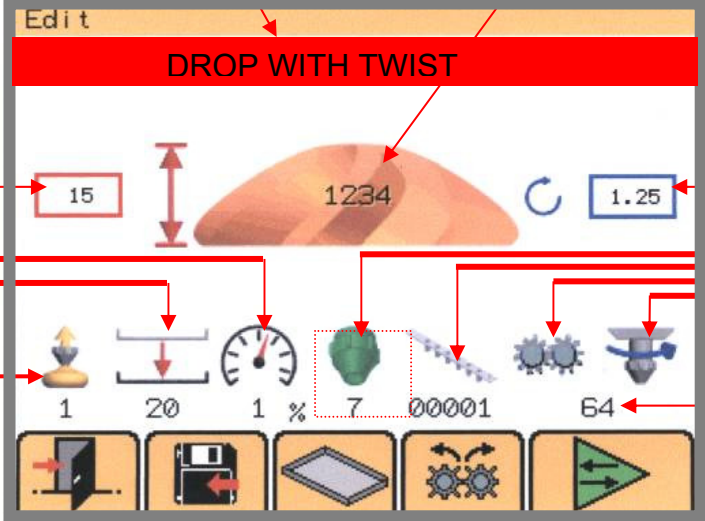

EXIT THIS SCREEN



SAVE EDITS

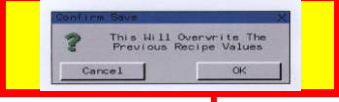

SUCK BACK
QUANTITY

TABLE
JOG DISTANCE (mm)

OVERALL
MACHINE SPEED
(% OF MAXIMUM)

ENTER TRAY
SETUP
SCREEN
GO TO PART
5A

MAX HEIGHT FOR
HOPPER/TEMPLATE
COMBINATION

START
MANUAL MODE

PRIME PUMP
(SOFT DOUGH SHOWN)

NOTE
A RED BACKGROUND TO ANY
SETTING MEANS THAT THE
VALUE SHOULD BE
CORRECTED

TEMPLATE TYPE
ROTARY
NON-ROTARY

SELECT HOPPER
SOFT DOUGH

TEMPLATE NUMBER
ENTER VIA KEYPAD
THAT APPEARS WHEN
PRESSED

CHOOSE NOZZLE TYPE

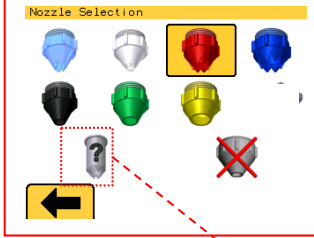

**EXAMPLE:
MULTIDROP WITH
TWIST**

**SETTING ERROR
INDICATOR**

BOXES TURN RED WHEN
INCORRECT SETTING
IS MADE

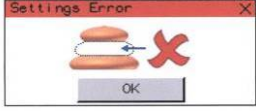

DEPOSIT QUANTITY FOR EACH LAYER

NOZZLE HEIGHT (mm) FOR EACH LAYER

NOZZLE HEIGHT (mm) FROM TRAY SURFACE

NUMBER OF TURNS FOR EACH LAYER (-VE VALUES POSSIBLE)

OTHER SETTING BUTTONS ARE THE SAME AS LAST PAGE

PRIME PUMP (HARD DOUGH SHOWN)

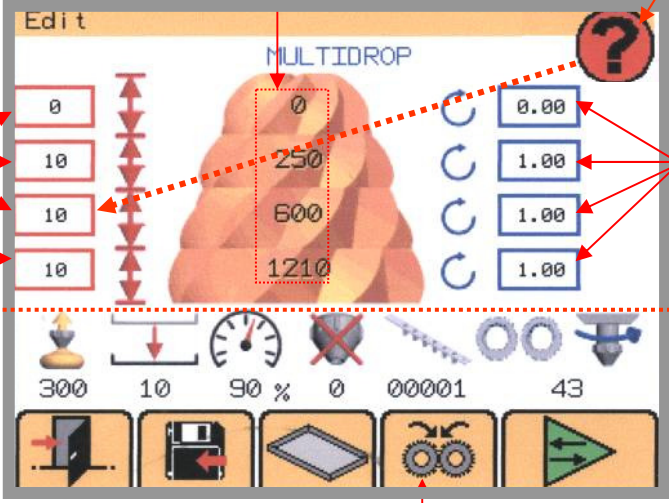

**EXAMPLE:
SHEETING / STRIP**

DEPOSIT QUANTITY FOR BEGINNING OF PRODUCT

DEPOSIT QUANTITY FOR LENGTH

DEPOSIT QUANTITY FOR END OF PRODUCT (-VE VALUES POSSIBLE)

NOZZLE HEIGHT ABOVE TRAY SURFACE

LENGTH (mm) OF TRAY MOVEMENT

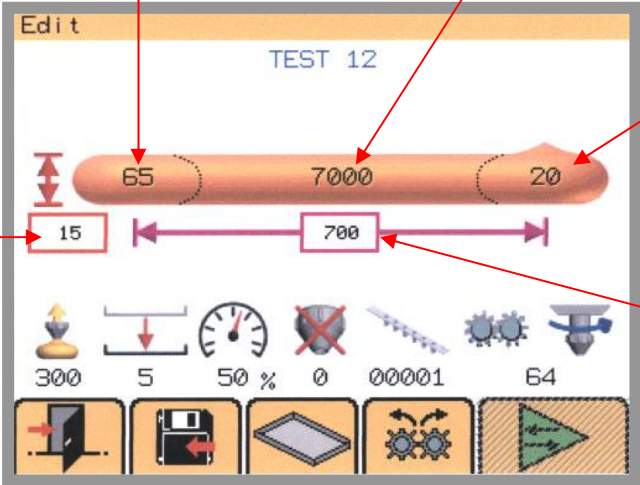

**EXAMPLE:
"C" SHAPE
(ARC)**

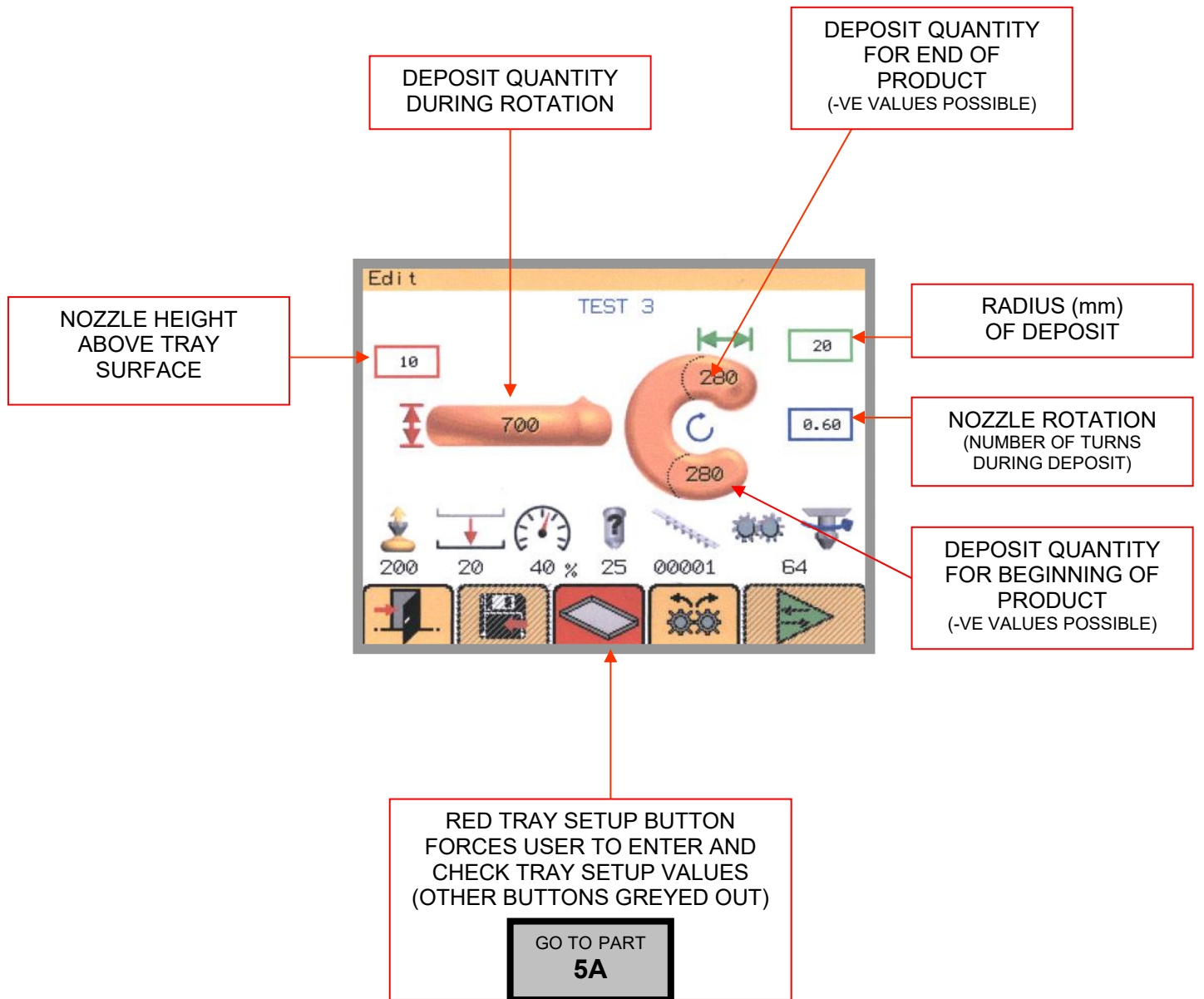

TRAY SETUP

5A

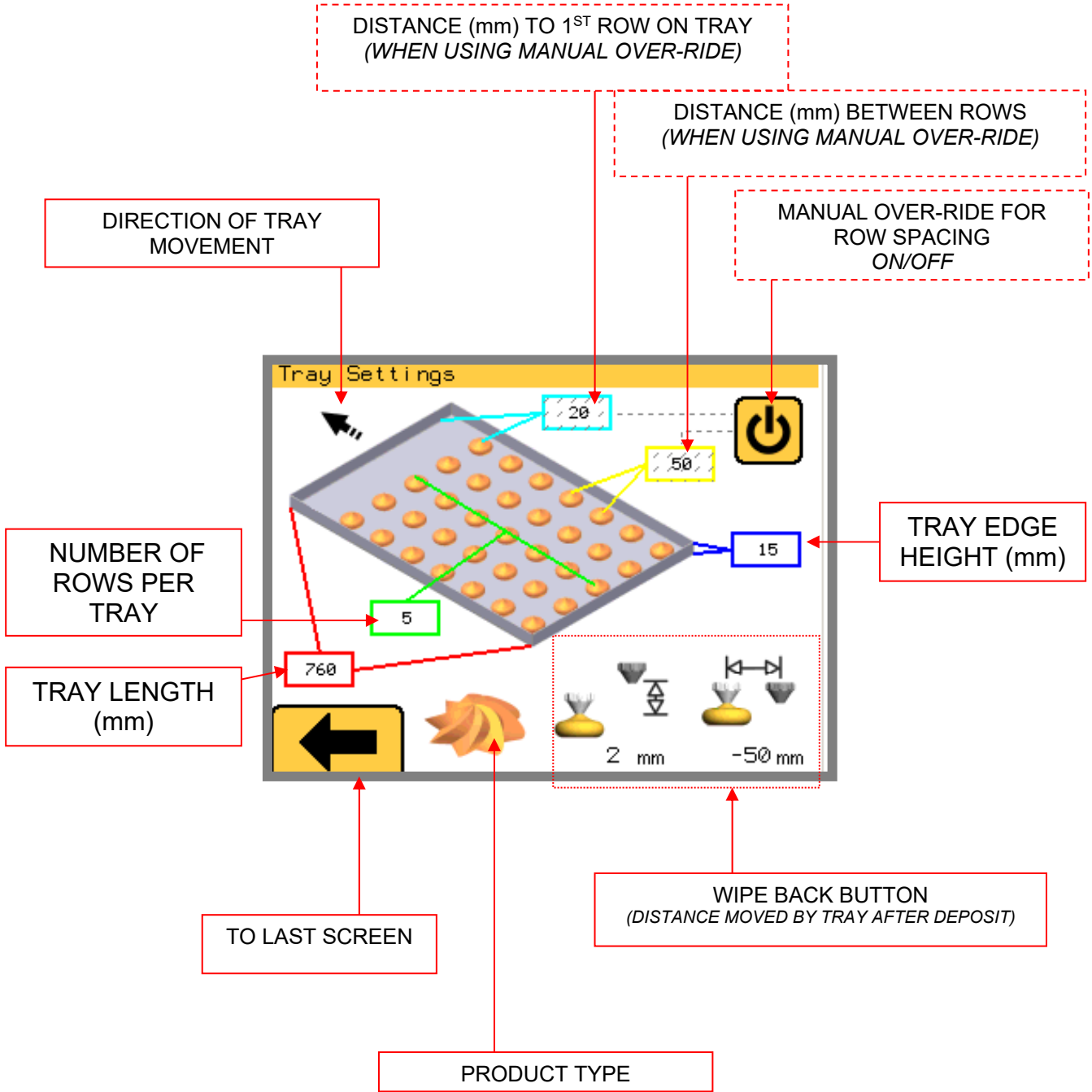

COPY

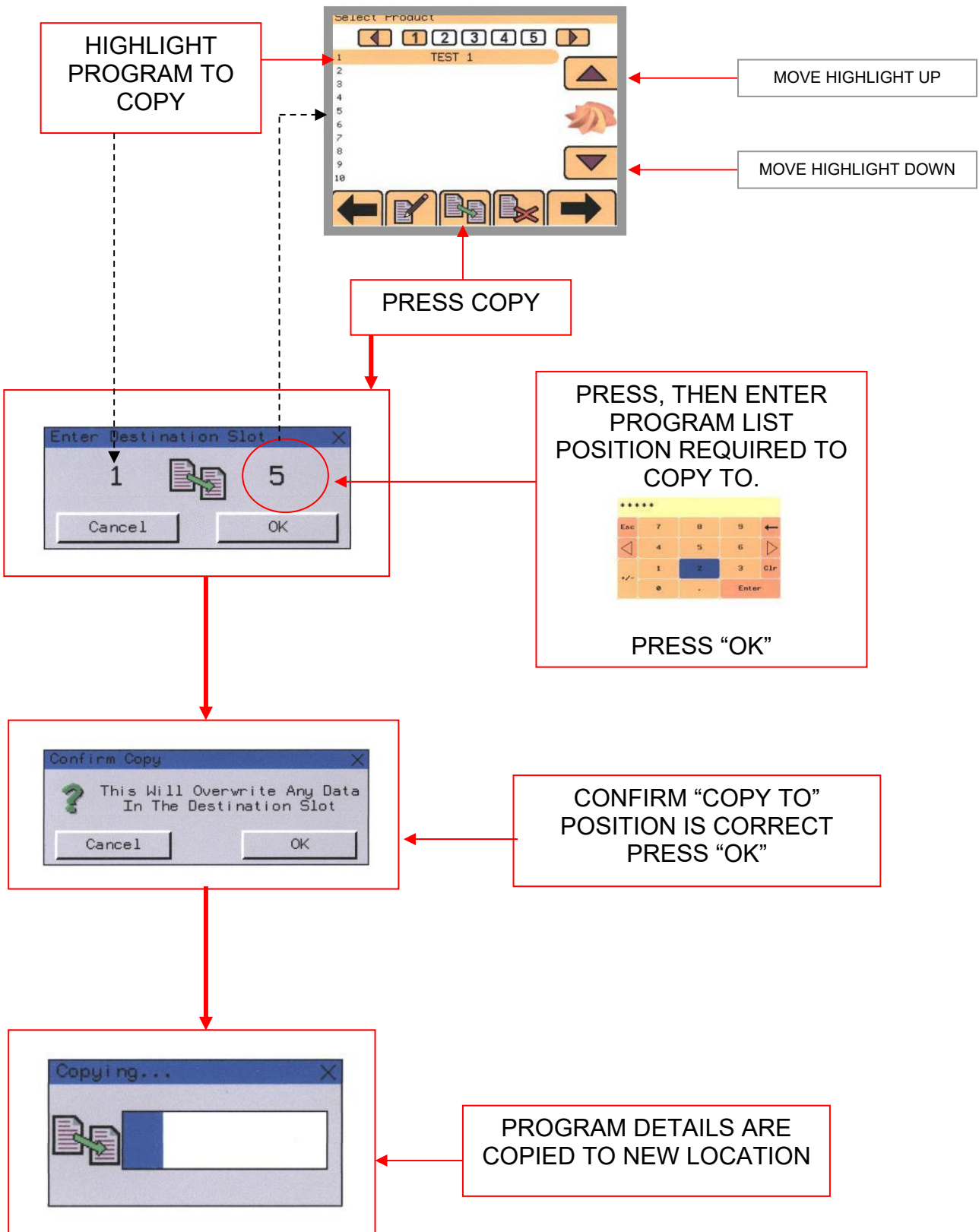

DELETE

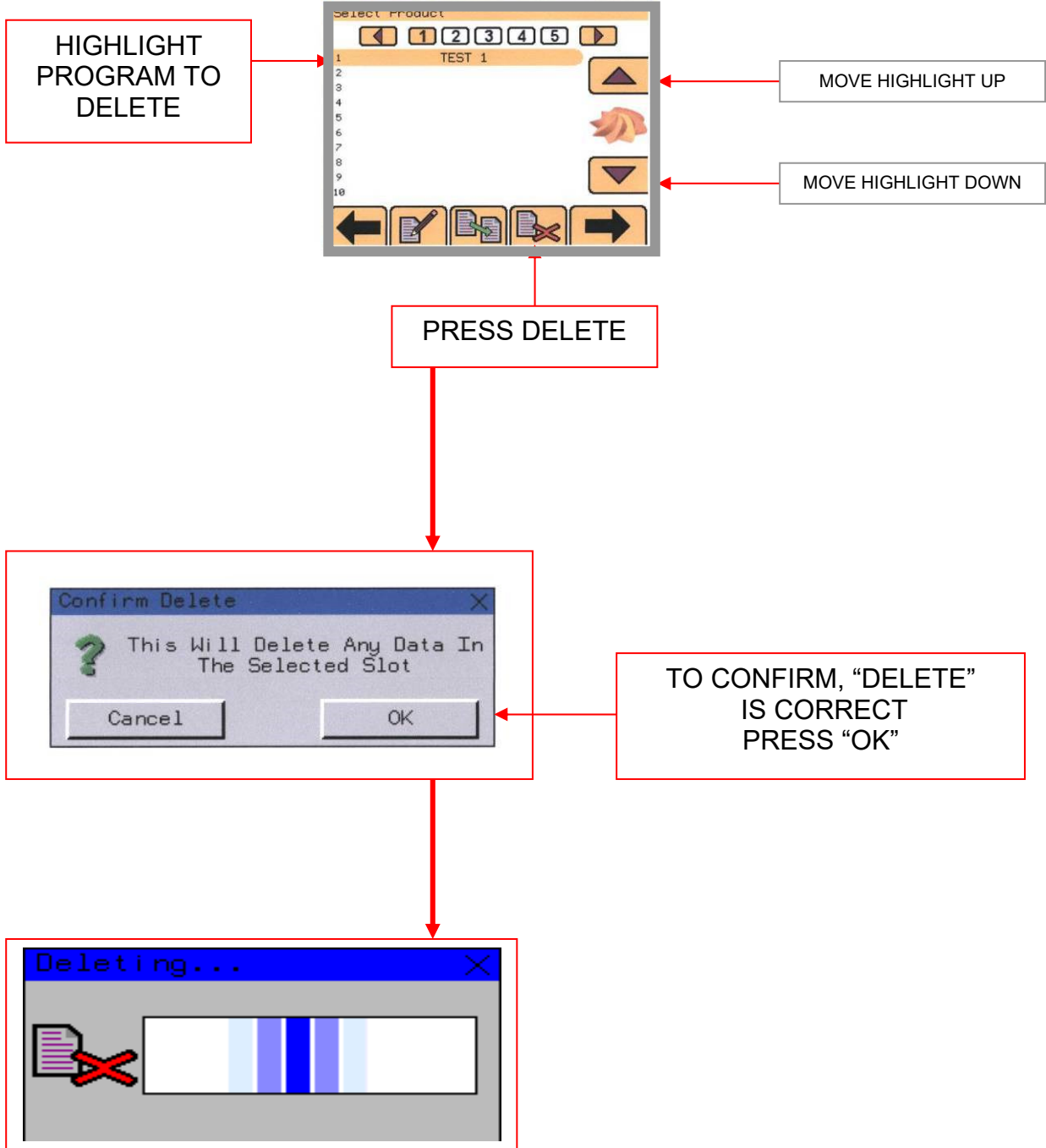

ENGINEERING SETTINGS (1)

THIS SECTION IS FOR TRAINED ENGINEERS ONLY



IN MANUAL MODE:
DISTANCE THAT THE LEADING EDGE
OF THE TRAY IS BROUGHT BACK
PASSED THE TRAY SENSOR, WHEN
RETURNING TO OPERATOR

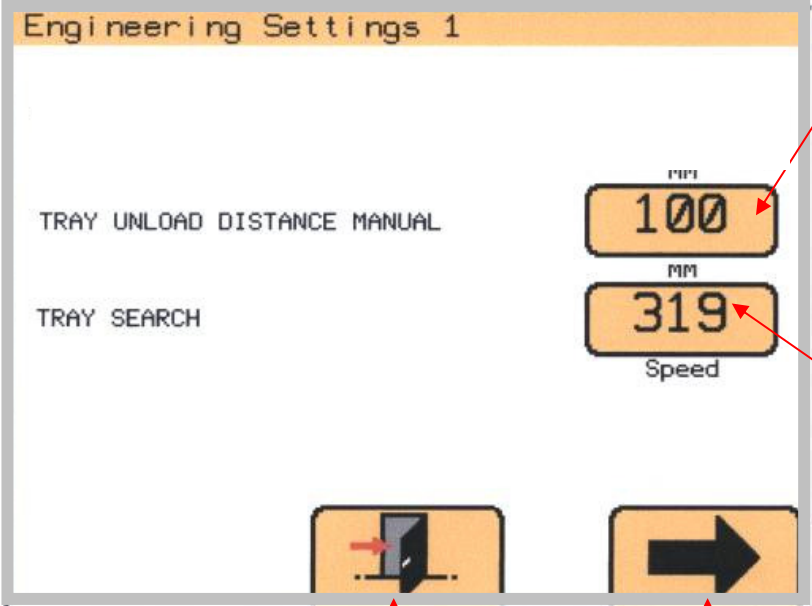

SPEED VALUE THAT TRAY IS
FED UP TO TRAY SENSOR



EXIT
THIS SCREEN

GO TO NEXT SCREEN
ENGINEERING SETTING 2
(NEXT PAGE)

CAUTION

DO NOT ATTEMPT TO MAKE ADJUSTMENTS UNLESS YOU ARE FULLY AWARE OF THE RESULTS

ENGINEERING SETTINGS (2)

THIS SECTION IS FOR TRAINED ENGINEERS ONLY

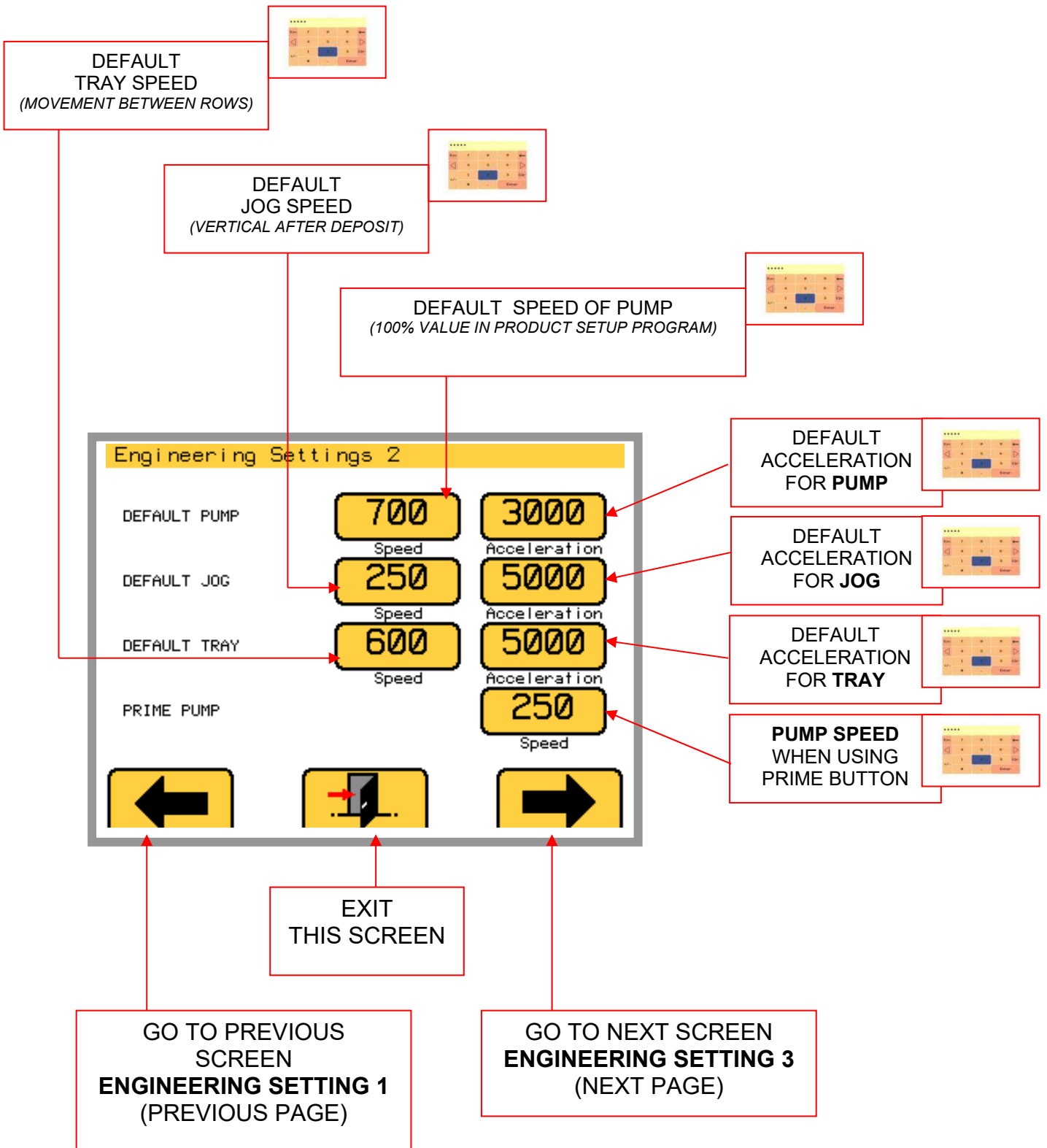

CAUTION

DO NOT ATTEMPT TO MAKE ADJUSTMENTS UNLESS YOU ARE FULLY AWARE OF THE RESULTS

ENGINEERING SETTINGS (3)

THIS SECTION IS FOR TRAINED ENGINEERS ONLY

The screenshot shows the 'Engineering Settings 3' screen with the following settings:

- HARD DOUGH OFFSET: 13
- SOFT DOUGH OFFSET: 0
- HARD DOUGH CENTRE LINE OFFSET: -19
- SOFT DOUGH CENTRE LINE OFFSET: 0

Navigation buttons at the bottom include a left arrow, an 'EXIT THIS SCREEN' button, and a right arrow.

Callouts provide detailed information for each setting:

- OFFSET HEIGHT VALUE (mm) HARD DOUGH HOPPER NON-ROTARY TEMPLATE:** 13
- OFFSET HEIGHT VALUE (mm) HARD DOUGH HOPPER ROTARY TEMPLATE:** 37
- OFFSET HEIGHT VALUE (mm) SOFT DOUGH HOPPER ROTARY TEMPLATE:** 0
- OFFSET HEIGHT VALUE (mm) SOFT DOUGH HOPPER NON-ROTARY TEMPLATE:** 16
- DISTANCE (mm) FROM HARD DOUGH HOPPER DEPOSITING CENTRELINE TO TRAY EDGE DETECTION POINT (USED IN ROW SPACING CALCULATIONS):** -19
- DISTANCE (mm) FROM SOFT DOUGH HOPPER DEPOSITING CENTRELINE TO TRAY EDGE DETECTION POINT (USED IN ROW SPACING CALCULATIONS):** 0

Navigation instructions:

- GO TO PREVIOUS SCREEN ENGINEERING SETTING 2 (PREVIOUS PAGE)** (Left arrow)
- EXIT THIS SCREEN** (Exit button)
- GO TO NEXT SCREEN ENGINEERING SETTING 4 (NEXT PAGE)** (Right arrow)

WARNING: OFFSET HEIGHT VALUE IS FACTORY SET AND SHOULD NOT BE CHANGED UNLESS INSTRUCTED TO DO SO. DAMAGE TO THE MACHINE COULD OCCUR.

CAUTION

DO NOT ATTEMPT TO MAKE ADJUSTMENTS UNLESS YOU ARE FULLY AWARE OF THE RESULTS

ENGINEERING SETTINGS (4)

THIS SECTION IS FOR TRAINED ENGINEERS ONLY

GEARBOX RATIOS

The screenshot displays the 'Engineering Settings 4' screen with the following data:

Setting	Value 1	Value 2
PUMP GEARBOX RATIO	28	1
TRAY GEARBOX RATIO	10	1
JOG GEARBOX RATIO	15	1
ROTARY GEARBOX RATIO	10	1

Navigation and Exit options:

- Left arrow: GO TO PREVIOUS SCREEN ENGINEERING SETTING 3 (PREVIOUS PAGE)
- Center icon: EXIT THIS SCREEN
- Right arrow: GO TO NEXT SCREEN ENGINEERING SETTING 5 (NEXT PAGE)

Callouts on the right side of the screen:

- PUMP
- TRAY
- JOG
- ROTARY

CAUTION

DO NOT ATTEMPT TO MAKE ADJUSTMENTS UNLESS YOU ARE FULLY AWARE OF THE RESULTS

ENGINEERING SETTINGS (5)

THIS SECTION IS FOR TRAINED ENGINEERS ONLY

WIPE BACK DEFAULT SETTINGS (SEE 5A)

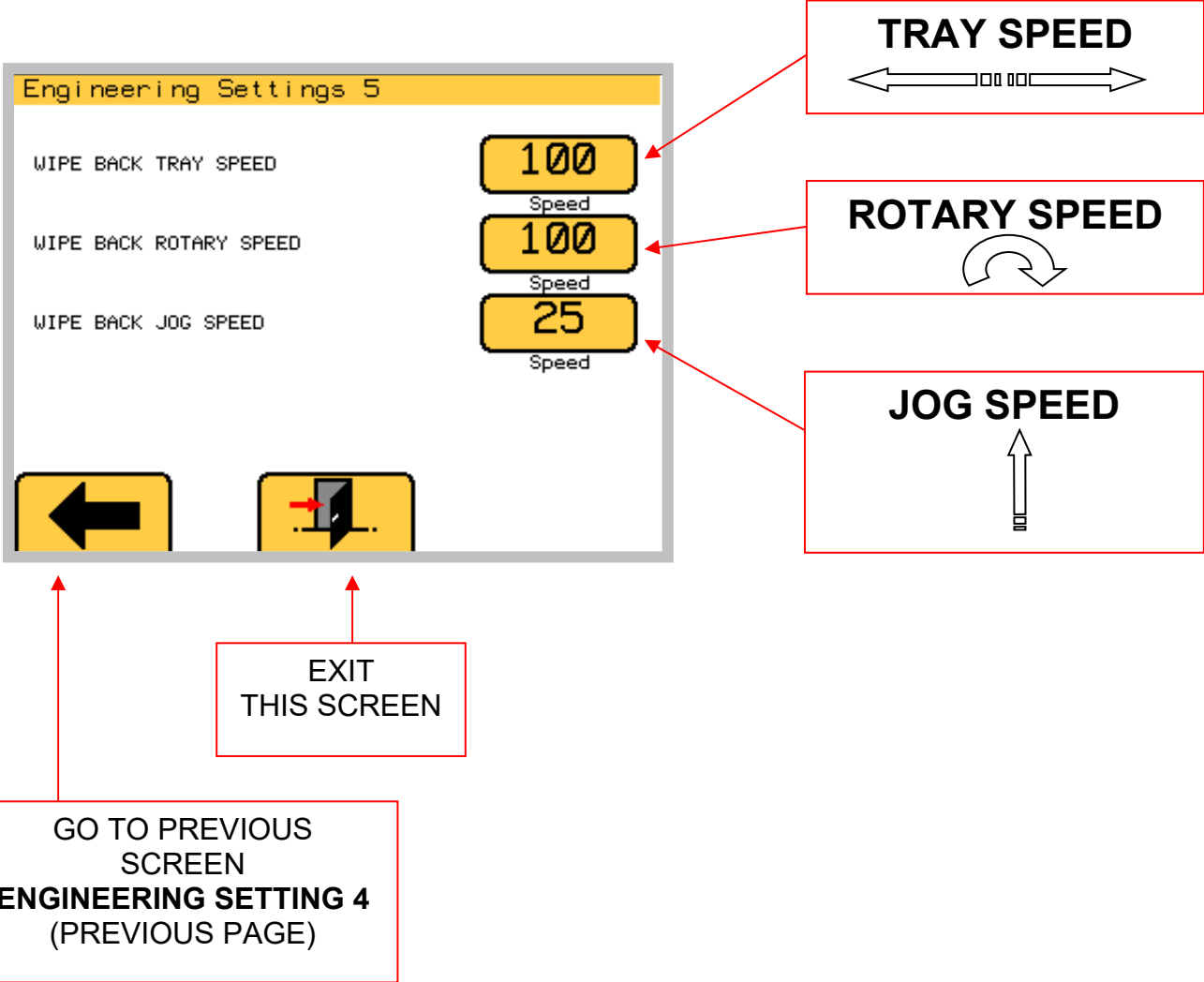

CAUTION

DO NOT ATTEMPT TO MAKE ADJUSTMENTS UNLESS YOU ARE FULLY AWARE OF THE RESULTS

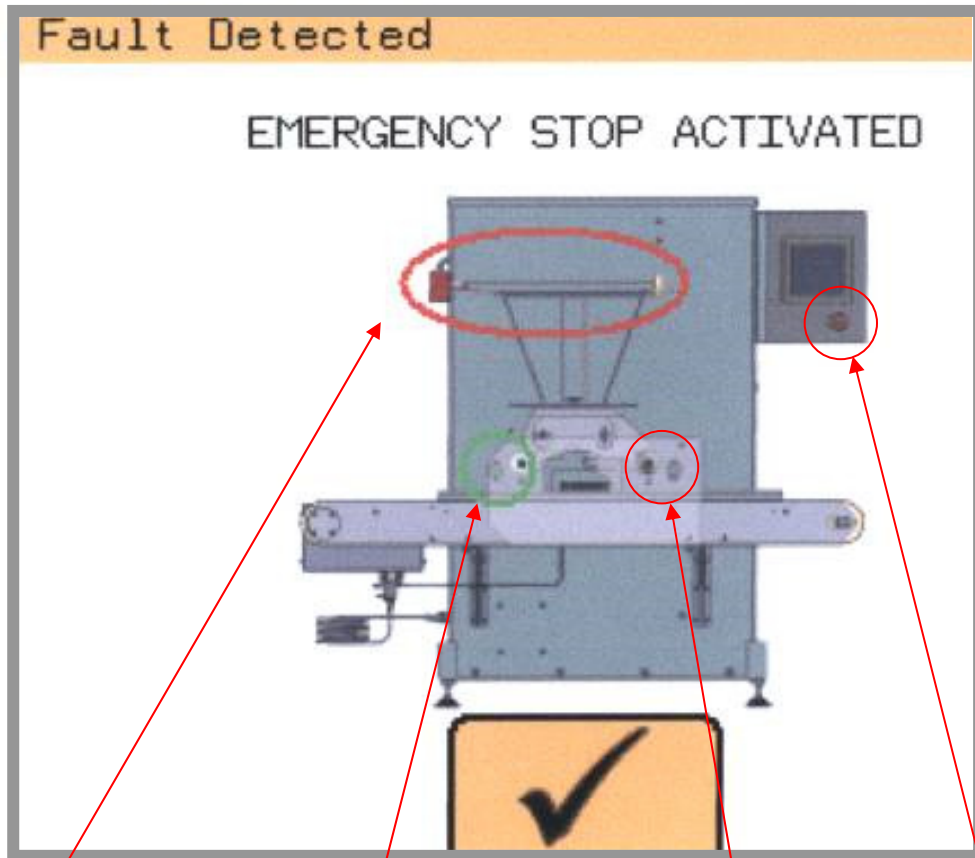

HOPPER COVER

SAFETY BEAM

SAFETY BEAM

STOP BUTTON

THIS SCREEN INDICATES A FAULT CONDITION IN THE SAFETY AREAS.

WHEN **RED**, CLOSE COVER OR CLEAR OBSTRUCTIONS TO CLEAR FAULT.
WHEN INDICATOR GOES **GREEN**, FAULT HAS BEEN CORRECTED AT THAT POSITION.

PRESS  BUTTON TO CLEAR SCREEN

IF THE FOLLOWING SCREEN APPEARS, CHECK THAT THE TABLE MOVEMENT ETC. IS NOT JAMMED WITH SOMETHING. IF IT IS, CLEAR THE OBSTRUCTION AND PRESS  TO PROCEED.

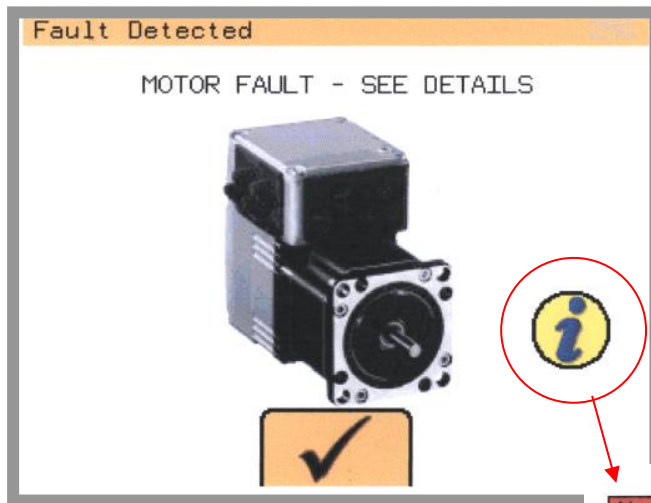

PRESS THIS BUTTON IF MORE INFORMATION IS REQUIRED AS TO WHICH MOTOR IS AT FAULT

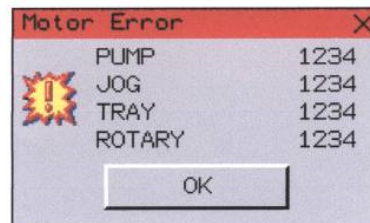

IF THE FAULT IS NOT OBVIOUS AND NOT ABLE TO BE CLEARED SAFELY, A SUITABLY TRAINED ENGINEER SHOULD BE CALLED

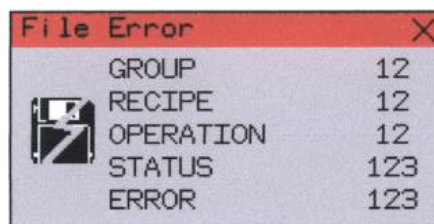

ERROR WHEN LOADING/SAVING RECIPE DATA TO HMI STORAGE CARD
PLEASE CONTACT SERVICE DEPT. / ENGINEER IF PROBLEM PERSISTS

DEVICE MANAGEMENT

Device Management allows you to **backup / restore recipes and settings**, and **update your system software**.

How to access the device management functions

1. Touch the **Settings** icon at the bottom of the screen (Hammer and Spanner).

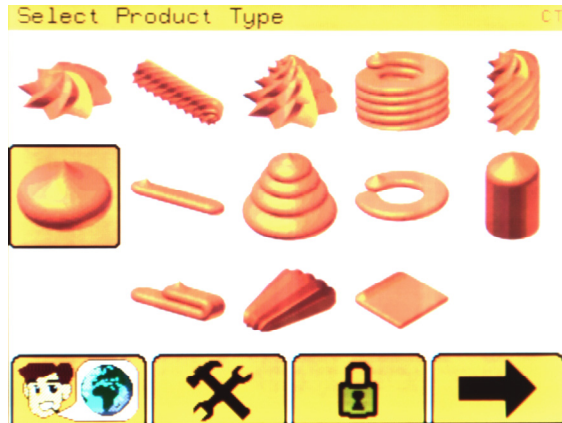

2. Input the Password **1793** and press the **Enter** button.

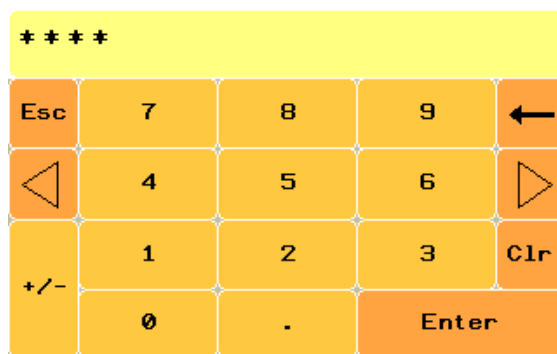

3. If backing up or restoring recipes/settings, now insert a USB memory stick (pen drive) into the USB port below the control panel enclosure. **(The software update requires this step later).**



4. When the **Device Management Screen** appears, select from Backup, Update, and Restore.



BACKUP

1. Touch the **BACKUP** button on the Device Management Screen.
2. Touch **Back up to USB** to save recipes and settings to the USB memory stick (pen drive).

Note that any existing recipes or settings on the USB memory stick are erased.



3. Touch the **Back** button (bottom of the screen) to return to the Select Product Type screen.

UPDATE (Software Update Only)

1. Touch the **UPDATE** button on the Device Management Screen.
2. When the screen below is displayed, insert the USB memory stick (pen drive) containing the software update. The update will then automatically begin.



3. Touch the **Back** button (bottom of the screen) to return to the Select Product Type screen.

RESTORE

1. Touch the **RESTORE** button on the Device Management Screen.
2. Touch **Restore From USB** to import recipes and settings from the USB memory stick (pen drive) to the Omega machine.

Note that this overwrites existing recipes and settings on the Omega machine.



3. Touch the **Back** button (bottom of the screen) to return to the Select Product Type screen.

RESTORE (Advanced)

1. Touch the **RESTORE** button on the Device Management Screen.
2. Touch the **Advanced** button at the bottom-right of the screen.
3. Touch **RESTORE RECIPES** to import only recipes from the USB memory stick (pen drive) to the Omega machine. **Note that this overwrites existing recipes on the Omega machine.**
4. Touch **RESTORE SETTINGS** to import only settings from the USB memory stick (pen drive) to the Omega machine. **Note that this overwrites existing settings on the Omega machine.**





- WARNING**
- This appliance must be maintained at regular intervals. The frequency of maintenance will depend upon your specific use and location. The maximum service interval should be 12 months.
 - Service and maintenance should only be undertaken by suitably qualified, trained, and competent engineers.
 - You must immediately report any damage or defect arising with the appliance.
 - Unsafe equipment is dangerous. Do not use the appliance. Isolate the power supply and contact **MONO** or your appointed service agent.

Under most conditions the machine only needs to be kept clean and used as instructed in this manual.



WARNING: Under no circumstances use a water hose or pressure washer to clean this machine.

Check and Maintenance Schedule

Operation	Daily	Weekly	Monthly	Yearly
Clean depositor as per instructions in the manual	*			
Check condition of supply lead and plug	*			
Check fit of guards	*			
Clean under conveyor belts		*		
Check hopper seals		*		
Check end cap seals		*		
Check condition and tension of conveyor (adjust or replace, as required)			*	
Check end cap bearings			*	
Check alignment of sensor on guards			*	
Check tray sensor is secure			*	
Check condition of idle roller bearings				*
Check condition of drive shaft bearings				*
Check condition and tension of chain and grease as required				*
Grease slides as required				*
Adjust eccentric guide rollers as required				*
Adjust concentric guide rollers as required				*
Check and grease all slide plates as required				*
Check all motor mounts are tight				*
Inspect electrical connections and tighten as required				*
Replace the button battery (M251 controller) ⁽¹⁾				*

⁽¹⁾ Internal data can be lost if the battery is depleted and should be replaced every 1 to 2 years (depending on the ambient temperature).



WARNING: Under no circumstances should maintenance or cleaning of this product machine be done with the power connected.

12.0 SPARES AND SERVICE

Omega Touch

If a fault arises, please do not hesitate to contact the Customer Service Department, quoting the **machine serial number** found on the silver information plate of the machine and on the front cover of this manual

UK SERVICE, SPARES and OVERSEAS SUPPORT:



Queensway
Swansea West Industrial Estate
Swansea. SA5 4EB UK

email: spares@monoequip.com
Website: www.monoequip.com

Spares Tel. +44(0)1792 564039
Main Tel. +44(0)1792 561234



13.0 SPARES

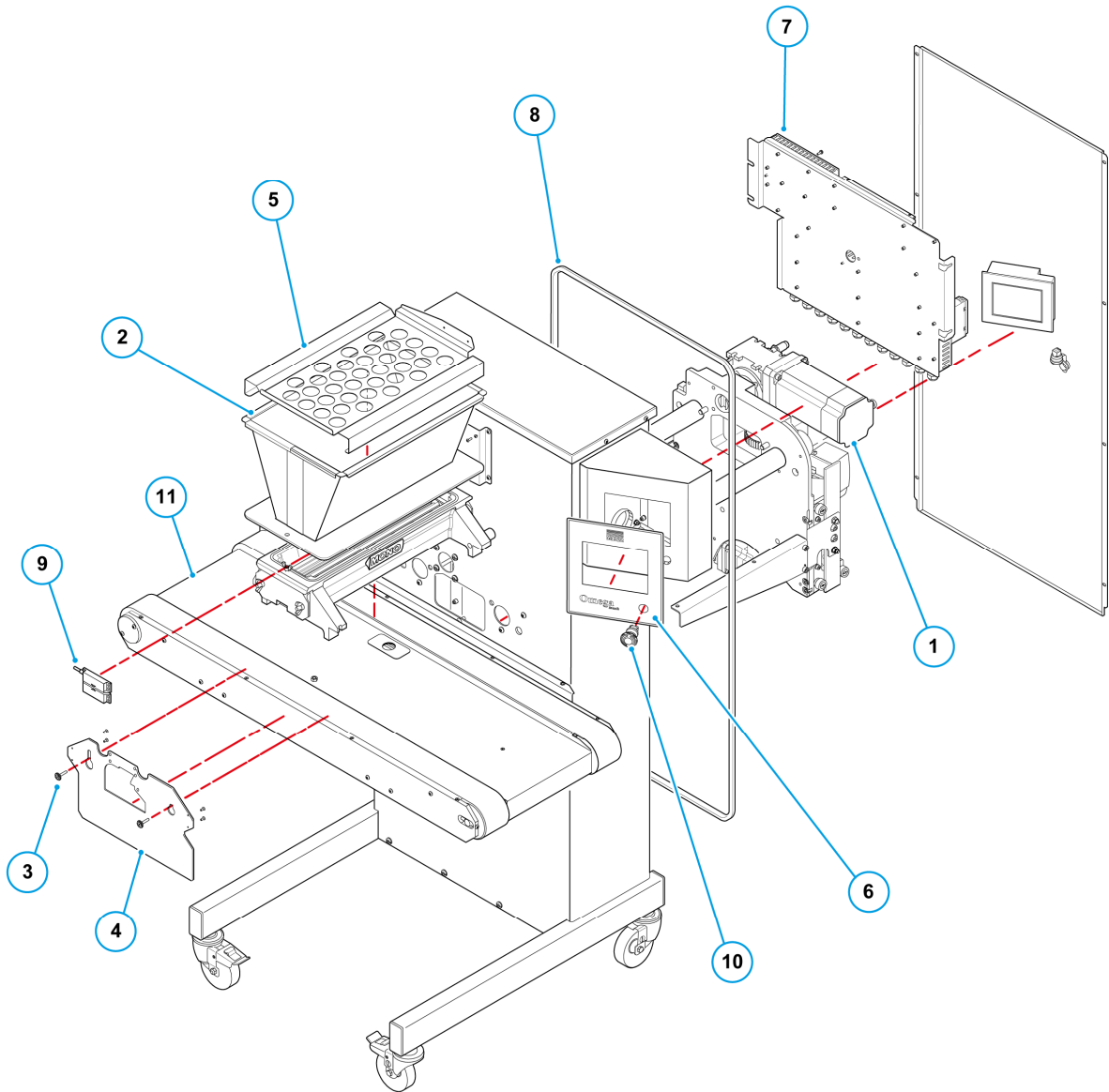

Table 13.1: Main assembly spare parts list

Item No.	Part number	Description (See Table 13.4 for other hopper sizes)
1	078-03-00052	MECHANICAL DRIVE ASSEMBLY (See Table 13.2)
2	078-09-00001	HOPPER (450mm) (See Table 13.3)
3	078-11-00035	RETAINER - END GUARD
4	078-11-00036	END GUARD (STAINLESS STEEL)
5	078-11-00067	POUR THROUGH GUARD (450mm)
6	078-90-00001	OMEGA TOUCH OVERLAY
7	079-25-00146	ELECTRICAL PANEL ASSEMBLY (See Table 13.5)
8	A900-25-309	DRAFT EXCLUDER (COMPOSITE SELF-GRIP TYPE)
9	B801-07-005	MAGNETIC SAFETY SWITCH
10	B801-12-003	PUSH LOCK STOP TYPE ZB4 BS54
11	See Table 13.6	CONVEYOR

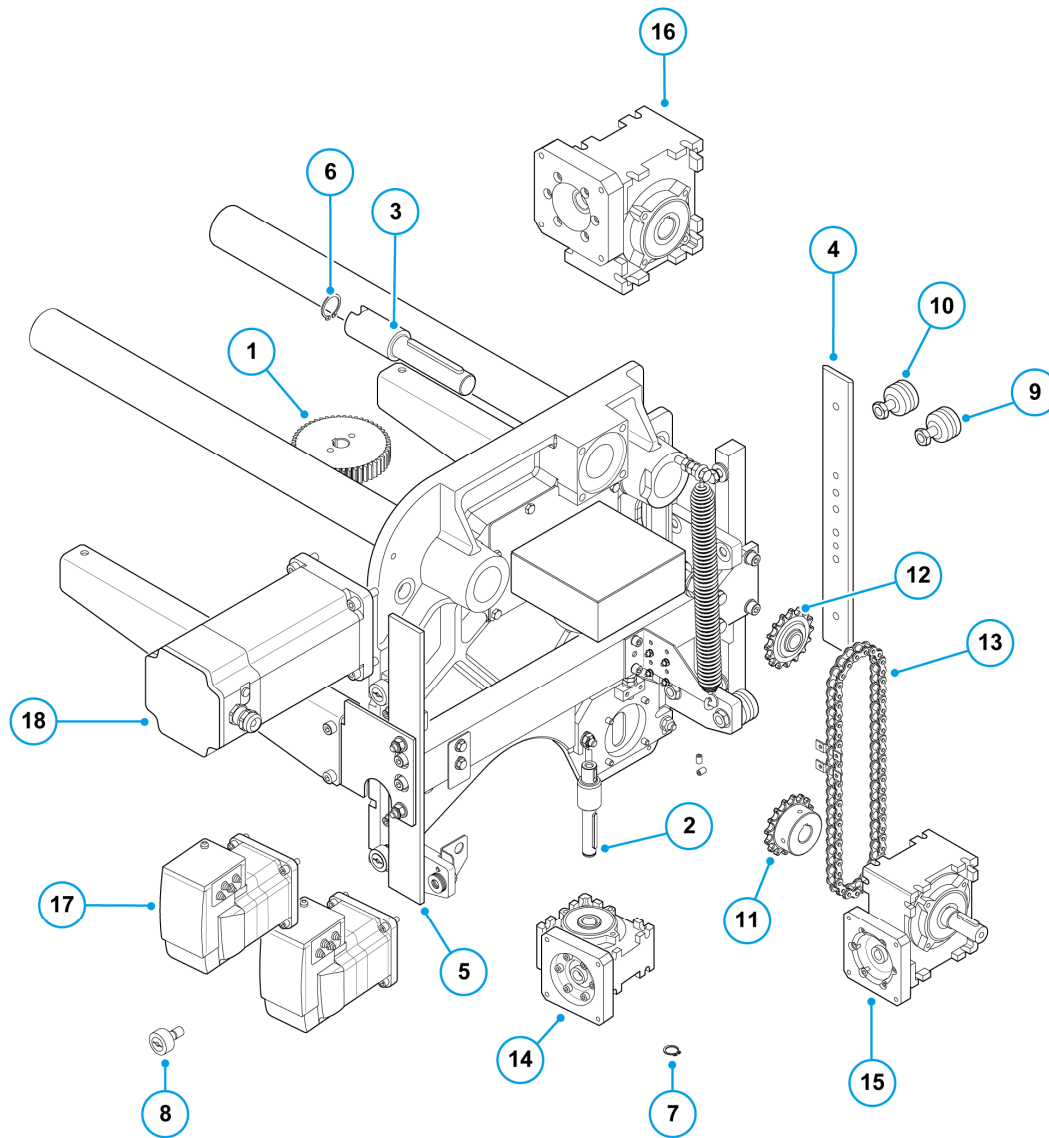

Table 13.2: Mechanical drive assembly spare parts list (400/450)

Item No.	Part number	Description
1	078-03-00010	DRIVE GEAR - ROTARY TEMPLATE
2	078-03-00011	ROTARY DRIVE SHAFT
3	078-03-00015	DRIVE SHAFT - HOPPER
4	078-03-00016	SLIDE PLATE
5	078-03-00027	SLIDE PLATE
6	A900-01-193	CIRCLIP-EXT METRIC, 24mm DIAMETER
7	A900-01-280	CIRCLIP-EXT METRIC, 14mm DIAMETER
8	A900-06-136	TRACK ROLLER - STUD TYPE
9	A900-06-273	HEPCO BRG LJ34EDR
10	A900-06-274	HEPCO BRG LJ34CDR

Item No.	Part number	Description
11	A900-07-071	SIMPLEX SPROCKET 16T 1/2" PITCH
12	A900-07-072	IDLER SPROCKET 16T 1/2" PITCH
13	A900-08-066	DRIVE CHAIN - OMEGA
14	A900-11-091	GEARBOX
15	A900-11-092	GEARBOX - SRT40
16	A900-11-097	DEPOSIT GEARBOX
17	B780-74-002	STEPPER MOTOR TYPE IFS91
18	B781-74-005	VRDM 31122 - 3-PHASE STEPPER MOTOR

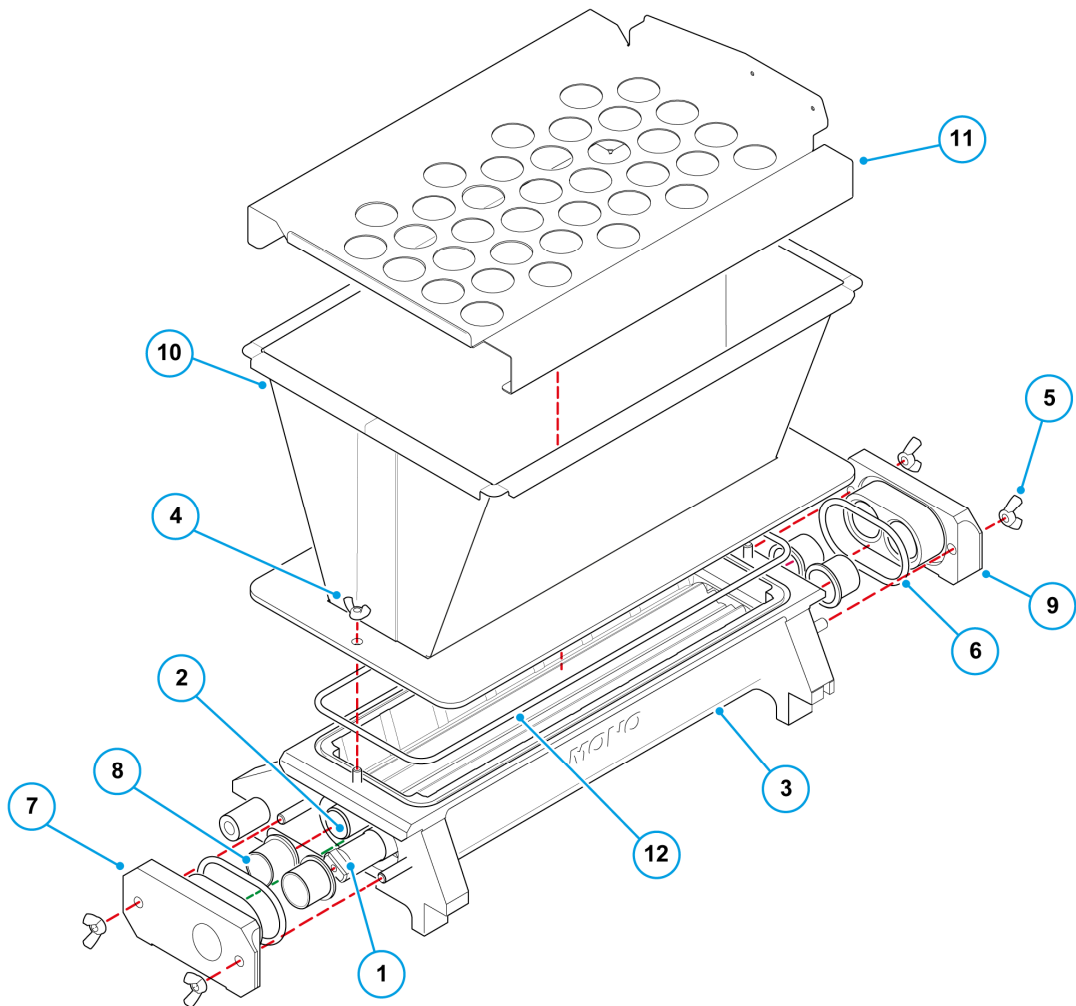

Table 13.3: Soft dough hopper (450mm) spare parts list

Item No.	Part number	Description (See Table 13.4 for other hopper sizes)
1	073-09-01600	10T DRIVER - 450mm HOPPER GEAR
2	073-09-01602	10T DRIVEN - 450mm HOPPER GEAR
3	073-09-02002	PUMP CASING (SOFT DOUGH) - 450mm
4	A900-04-043	M8 WING NUT (STAINLESS STEEL)
5	A900-04-147	M10 WING NUT (STAINLESS STEEL)
6	A900-12-074	O-RING 84.3 ID x 5.7 SECTION
7	073-09-00500	HOPPER END CAP - DRIVE SIDE
8	073-09-00600	END CAP BUSH
9	073-09-03200	HOPPER END CAP IDLER
10	078-09-00001	HOPPER, 450mm
11	078-11-00067	POUR THROUGH GUARD (450mm).
12	A900-12-084	O-RING 375 ID x 5.5 DIAMETER

Table 13.4: Soft dough hoppers (400/450/580mm)

Spare Part (Main Parts Item No.)	400mm Hopper	450mm Hopper	580mm Hopper
Standard Hopper (10)	078-09-00008	078-09-00001	078-09-00046
Extended Hopper (10)	073-09-00200	073-09-00202	073-09-00203
Hopper O-Ring Seal (12)	A900-12-083	A900-12-084	A900-12-085
Driven Gear (2)	073-09-00702	073-09-01602	073-09-01702
Drive Gear (1)	073-09-00700	073-09-01600	073-09-01700
Pour Through Guard (11)	078-11-00066	078-11-00067	078-11-00068
Hopper Base (3)	073-09-02000	073-09-02002	073-09-02003

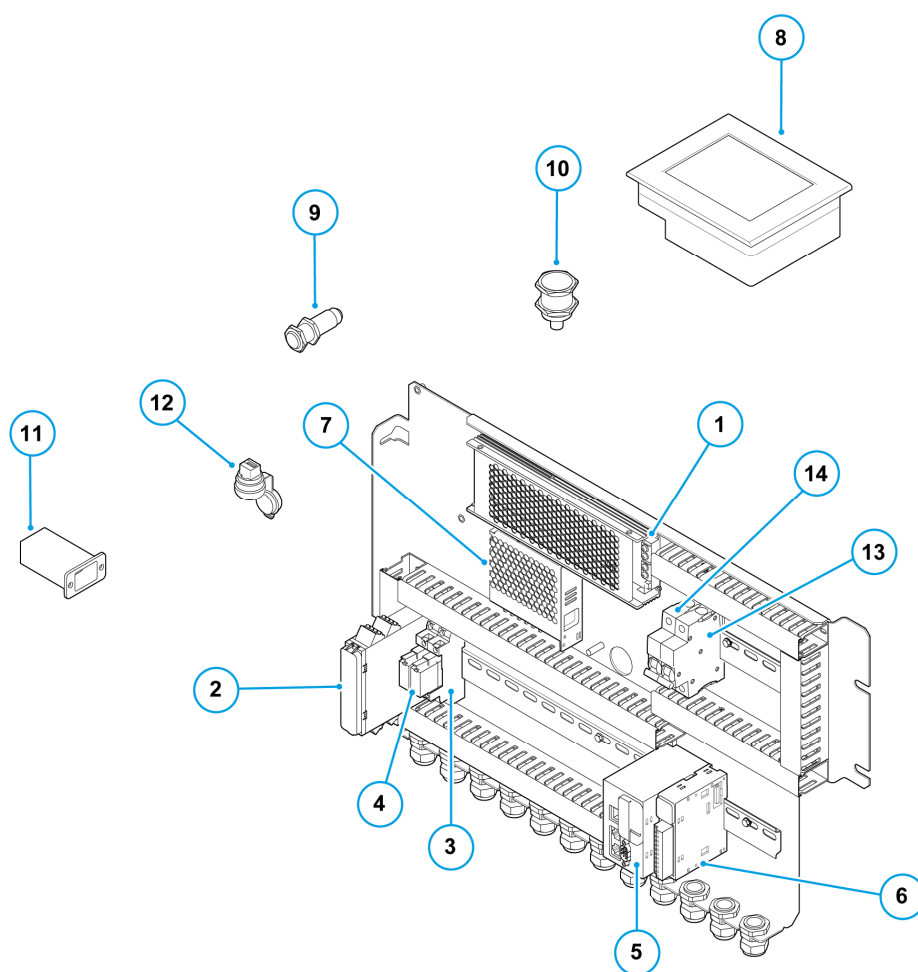

Table 13.5: Electrical panel assembly spare parts list

Item No.	Part number	Description
1	B782-93-005	500W POWER SUPPLY - SLIM TYPE (PFC SWITCHING SUPPLY)
2	B801-11-028	SAFETY RELAY
3	B801-36-002	RELAY BASE
4	B801-37-002	RELAY G2R/1/S
5	B801-80-055	CONTROLLER M251 – Ethernet + CANBUS
6	B801-80-056	MODULE TM3-8 INPUTS
7	B801-93-043	POWER SUPPLY - 75W SINGLE OUTPUT
8	B801-94-013	HMIGTO2310 FOR OMEGA DEPOSITORS
9	B801-99-007	PHOTOCELL UNIT - TYPE XUB1APANL2
10	B801-99-011	XS1N30PA349D - INDUCTIVE SENSOR
11	B842-06-031	IEC-C19 16A PANEL SOCKET (250V)
12	B842-06-036	INDUSTRIAL USB A SOCKET SEALED 22mm
13	B872-22-003	CIRCUIT BREAKER B CURVE 4A
14	B872-22-006	CIRCUIT BREAKER 16 A

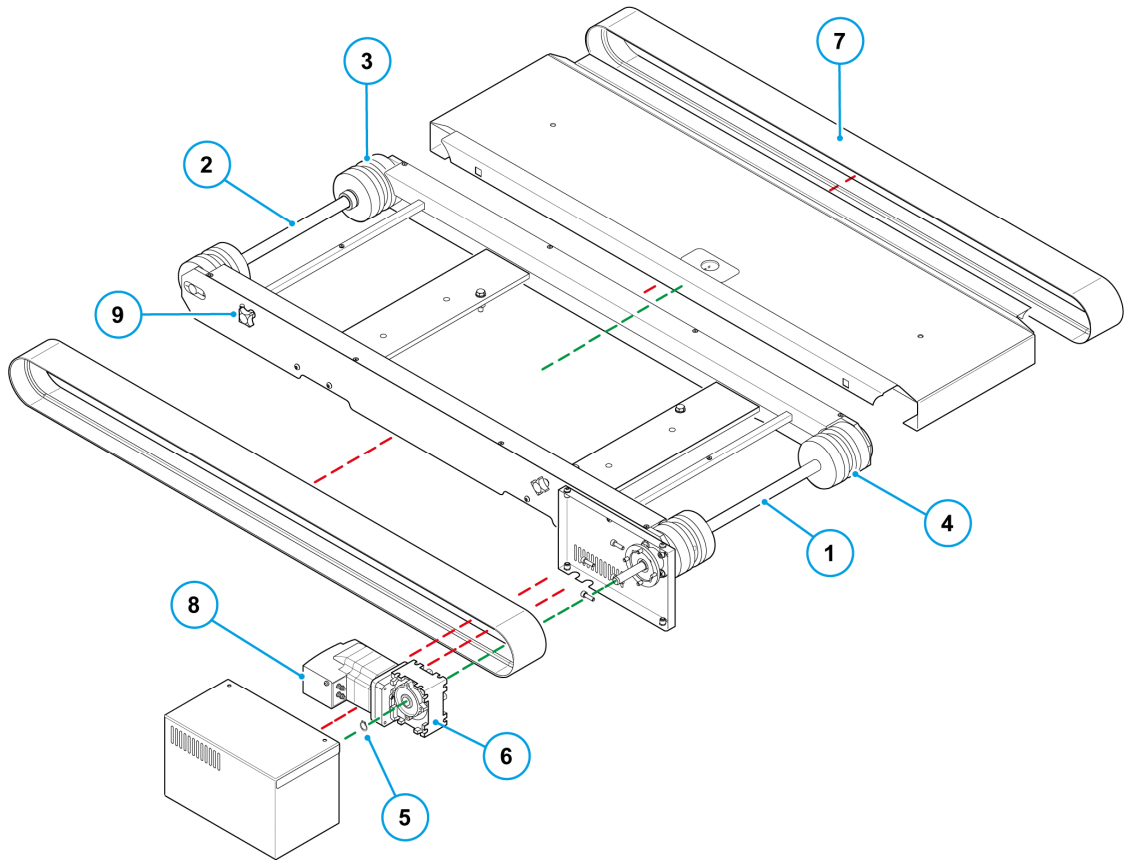

Table 13.6: Conveyor spare parts list

Item No.	Part number	Description
1	078-08-00003	DRIVE SHAFT
2	078-08-00004	IDLE SHAFT
3	078-08-00015	IDLE PULLEY
4	078-08-00017	DRIVE PULLEY
5	A900-01-280	CIRCLIP-EXT METRIC, 14mm DIAMETER
6	A900-11-091	GEARBOX
7	A900-22-120	BELT - CONVEYOR
8	B780-74-002	STEPPER MOTOR TYPE IFS91
9	P700-04-018	THUMB SCREW (STAR) TYPE 1507/M - PART No 15163V-(M6 x 20)

Intermediate bearing blocks and sealing strips

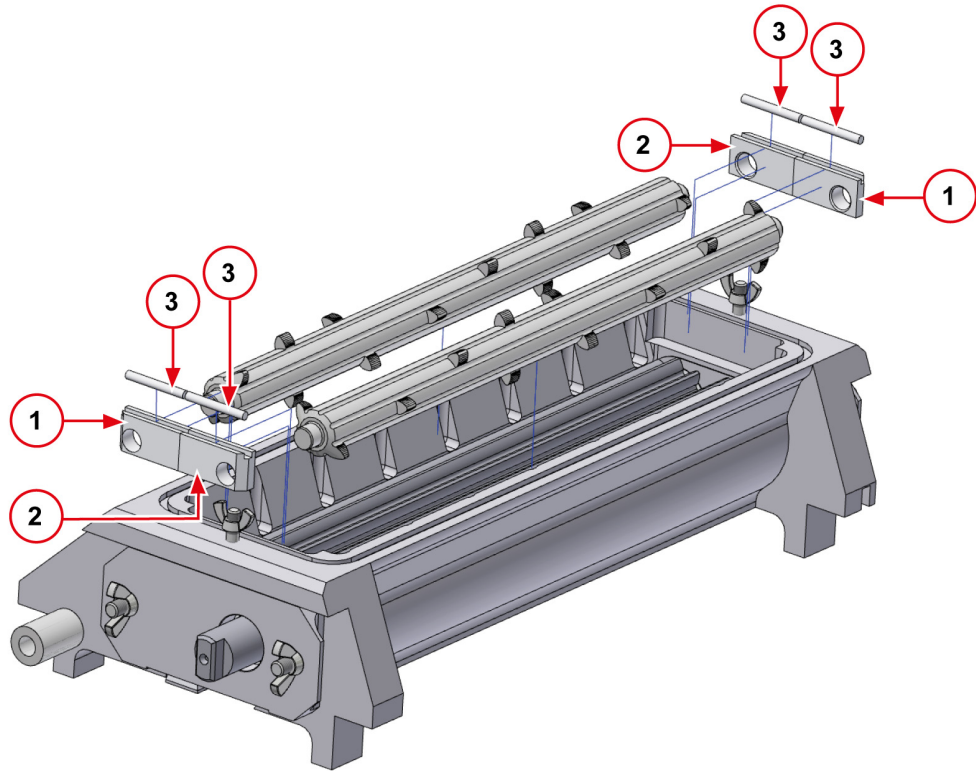
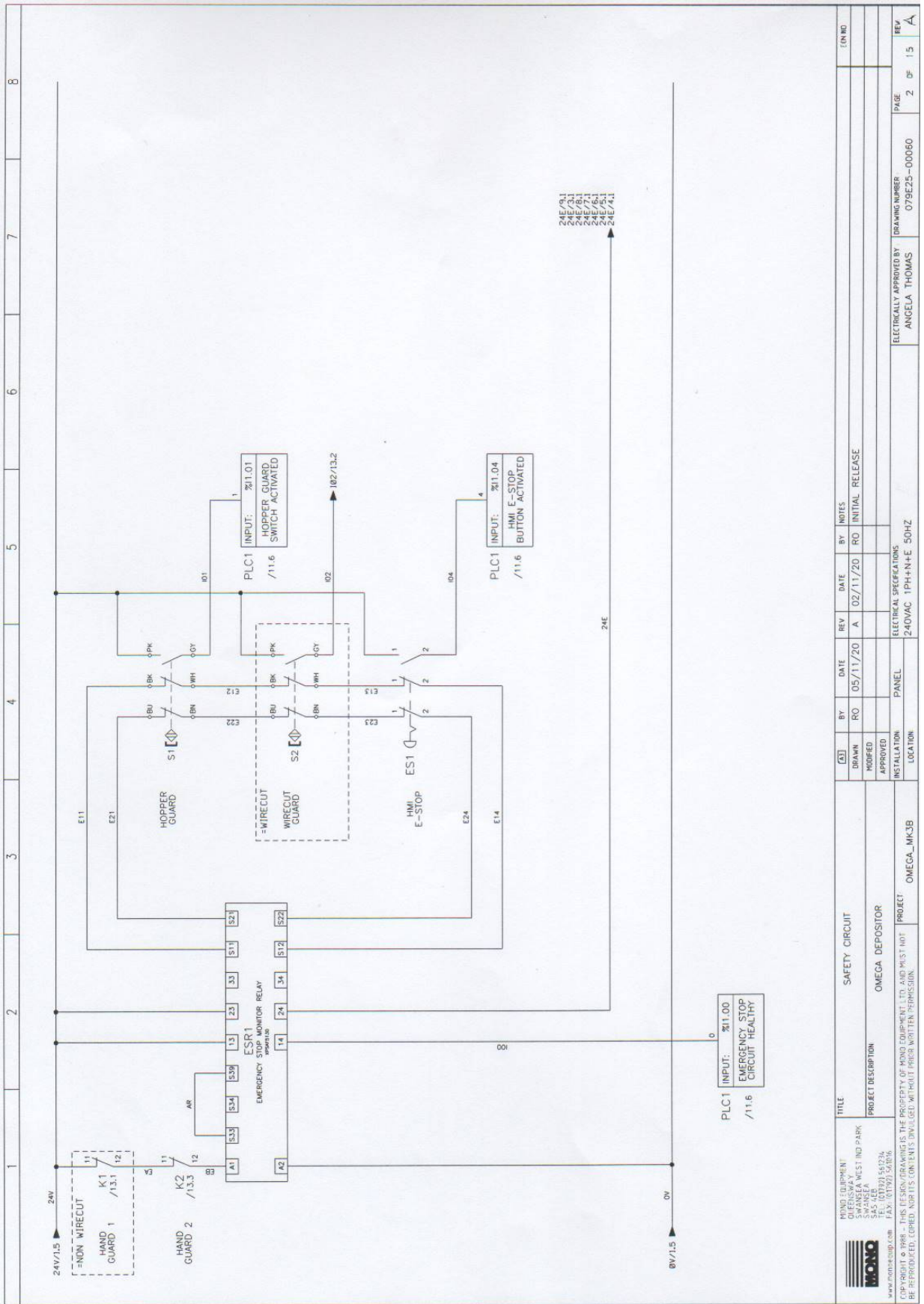

Table 13.7: Intermediate bearing blocks and seal strip spare parts list

Item no.	Part number	Description
1	073-09-10100	Intermediate bearing blocks (one required for each end)
2	073-09-10101	Intermediate bearing blocks (opposite hand, one required for each end)
3	073-09-10300	Intermediate bearing block sealing strip (two required for each end)



14.0 ELECTRICAL INFORMATION TOUCH VERSION



24E/11.5
24E/11.5
24E/11.5
24E/11.5
24E/11.5
24E/11.5
24E/11.5

PLC1 INPUT: %I1.00
EMERGENCY STOP
CIRCUIT HEALTHY
/11.6

PLC1 INPUT: %I1.04
HMI E-STOP
BUTTON ACTIVATED
/11.6

PLC1 INPUT: %I1.01
HOPPER GUARD
SWITCH ACTIVATED
/11.6

REV	DATE	BY	DATE	REV	DATE	BY	NOTES
A	02/11/20	RO	05/11/20	A	02/11/20	RO	INITIAL RELEASE

DESCRIPTION	DATE	BY	DATE	REV	DATE	BY	NOTES
INSTALLATION		RO	05/11/20	A	02/11/20	RO	INITIAL RELEASE
APPROVED							
APPROVED							

LOCATION	ELECTRICAL SPECIFICATIONS	ELECTRICALLY APPROVED BY	DRAWING NUMBER	PAGE	REV
OMEGA_MK3B	240VAC 1PH+N+E 50HZ	ANGELA THOMAS	079E25-00060	2	DF 1.5

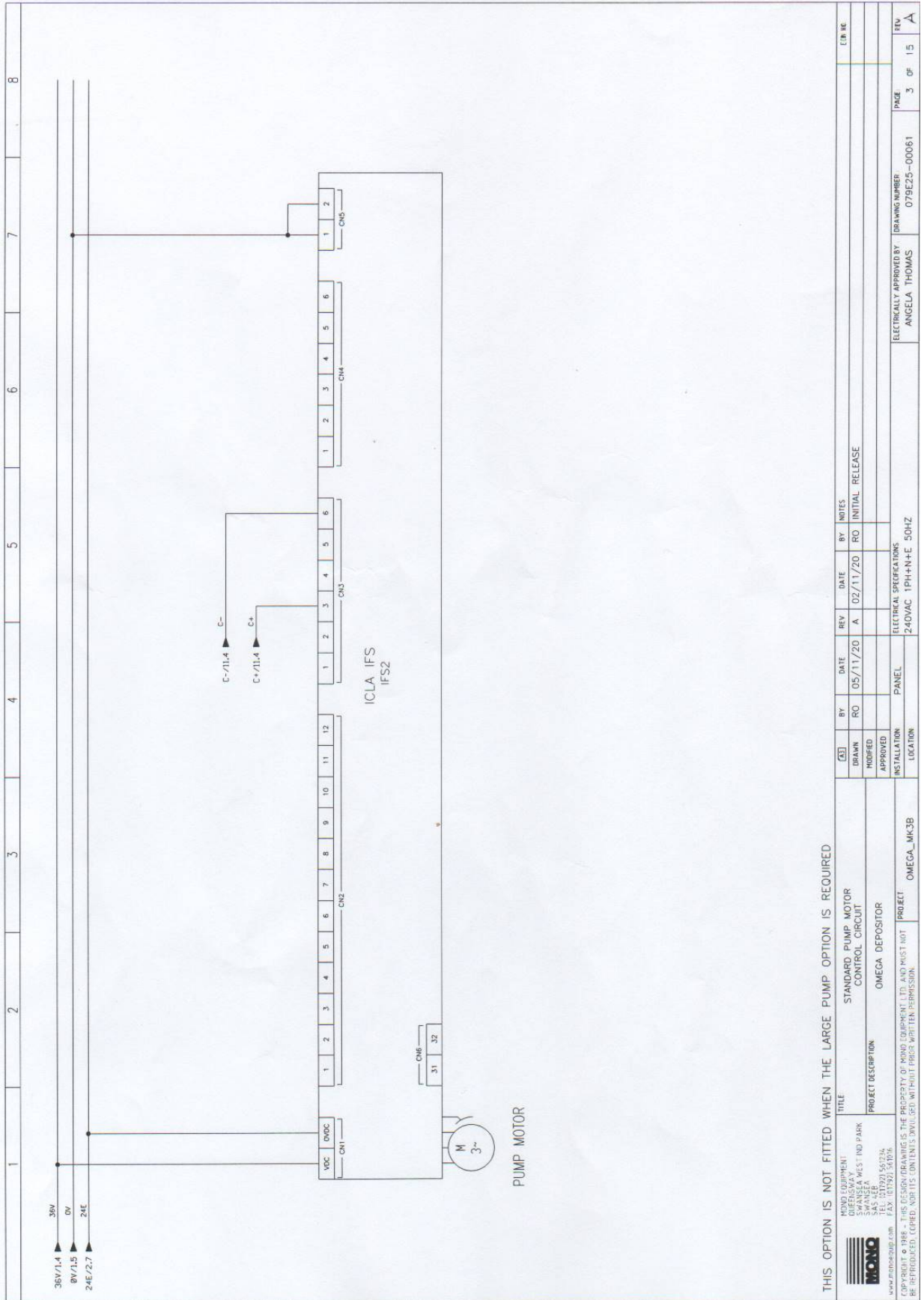

THIS OPTION IS NOT FITTED WHEN THE LARGE PUMP OPTION IS REQUIRED

		NEW EQUIPMENT QUEENSLAND SWANSEA WEST IND PARK SWANSEA QLD 4810 545 3488 TEL: 077320 56724 WWW.MONO.COM.AU		TITLE STANDARD PUMP MOTOR CONTROL CIRCUIT		DATE 05/11/20		REV A		DATE 02/11/20		BY RO		NOTES INITIAL RELEASE		REV A	
PROJECT DESCRIPTION OMEGA DEPOSITOR		PROJECT OMEGA_MK3B		INSTALLATION PANEL		ELECTRICAL SPECIFICATIONS 240VAC 1PH+1N+E 50HZ		ELECTRICALLY APPROVED BY ANGELA THOMAS		DRAWING NUMBER 079E25-00061		PAGE 3 OF 15		REV A			

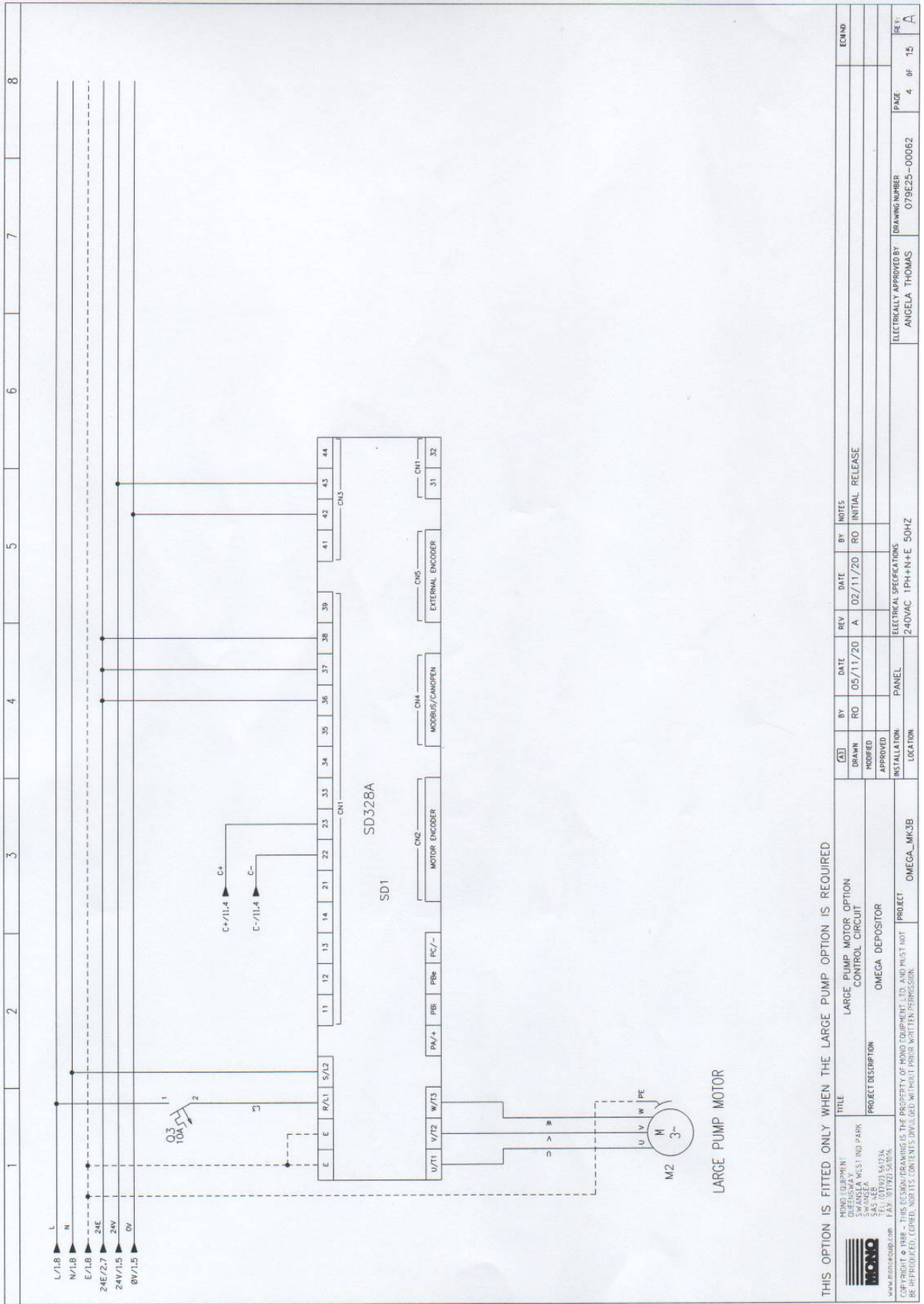

THIS OPTION IS FITTED ONLY WHEN THE LARGE PUMP OPTION IS REQUIRED

		MONO EQUIPMENT QUEENSLAND SWANSEA WEST IND PARK 54'S AEB QLD 4807 TEL: (07) 55 50 31 www.monoequip.com		TITLE LARGE PUMP MOTOR OPTION CONTROL CIRCUIT		BY RO 05/11/20 A 02/11/20 RO INITIAL RELEASE		ECN# 	
PROJECT DESCRIPTION OMEGA DEPOSITOR		INSTALLATION LOCATION OMEGA_MK3B		DATE 02/11/20		REV A		NOTES 	
PROJECT OMEGA_MK3B		ELECTRICAL SPECIFICATIONS 240VAC 1PH+N+E 50HZ		APPROVED BY ANGELA THOMAS		DRAWING NUMBER 079E25-00062		REVISION A	
DATE 02/11/20		DATE 02/11/20		DATE 02/11/20		DATE 02/11/20		DATE 02/11/20	
BY RO 05/11/20 A 02/11/20 RO INITIAL RELEASE		BY RO 05/11/20 A 02/11/20 RO INITIAL RELEASE		BY RO 05/11/20 A 02/11/20 RO INITIAL RELEASE		BY RO 05/11/20 A 02/11/20 RO INITIAL RELEASE		BY RO 05/11/20 A 02/11/20 RO INITIAL RELEASE	
APPROVED BY ANGELA THOMAS		APPROVED BY ANGELA THOMAS		APPROVED BY ANGELA THOMAS		APPROVED BY ANGELA THOMAS		APPROVED BY ANGELA THOMAS	
DRAWING NUMBER 079E25-00062		DRAWING NUMBER 079E25-00062		DRAWING NUMBER 079E25-00062		DRAWING NUMBER 079E25-00062		DRAWING NUMBER 079E25-00062	
REVISION A		REVISION A		REVISION A		REVISION A		REVISION A	
PAGE 4 OF 15		PAGE 4 OF 15		PAGE 4 OF 15		PAGE 4 OF 15		PAGE 4 OF 15	

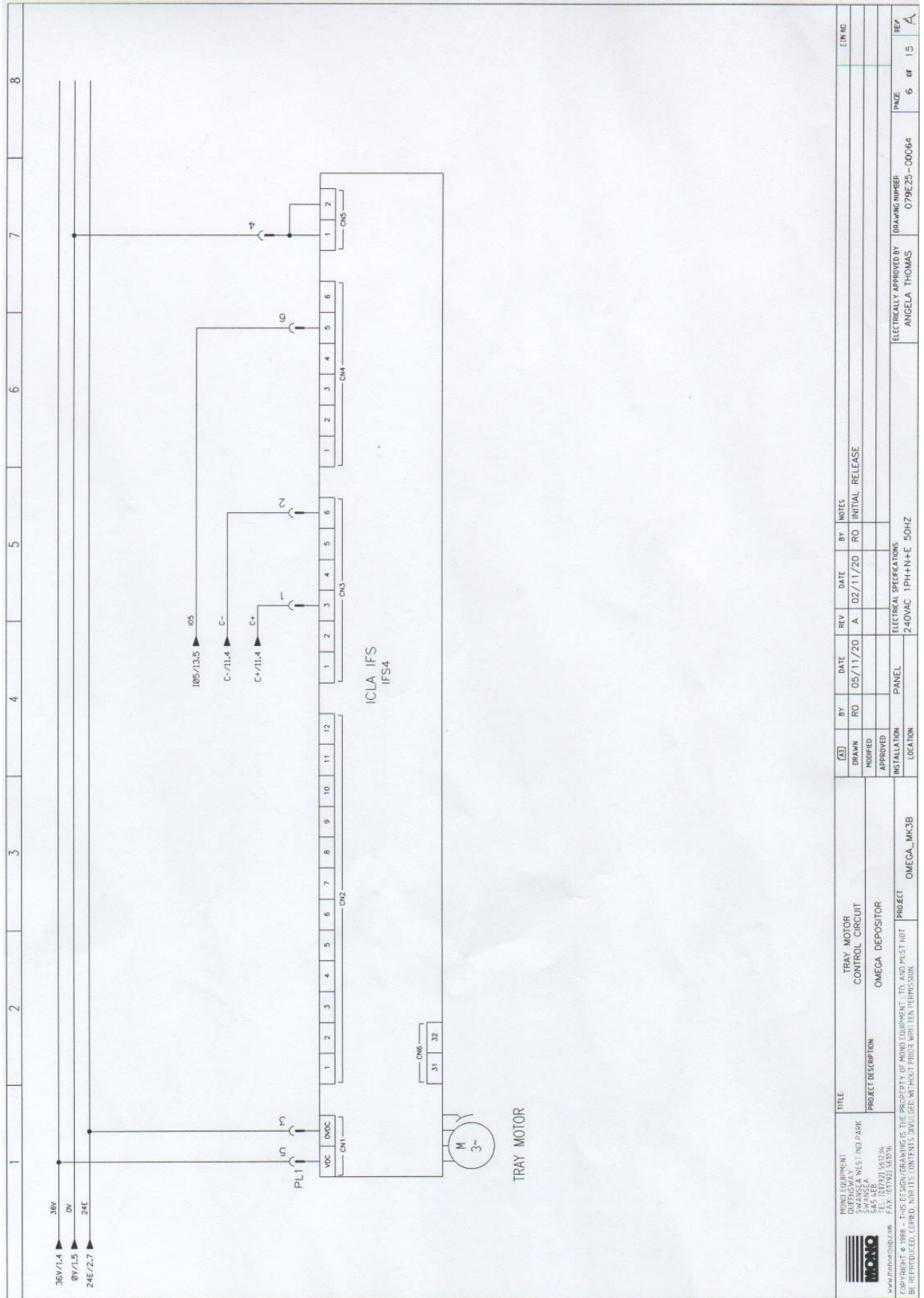

DATE	REV	DATE	REV	DATE	REV	DATE	REV	DATE	REV	DATE	REV	DATE	REV	DATE	REV	DATE	REV	DATE	REV										
05/11/20	A	02/11/20	A	02/11/20	A	02/11/20	A	02/11/20	A	02/11/20	A	02/11/20	A	02/11/20	A	02/11/20	A	02/11/20	A	02/11/20	A								
RO	RO	RO	RO	RO	RO	RO	RO	RO	RO	RO	RO	RO	RO	RO	RO	RO	RO	RO	RO	RO	RO								
DRAWN										INITIAL										RELEASE									
MODIFIED										APPROVED										ELECTRICAL SPECIFICATIONS									
INSTALLATION										PANEL										ELECTRICAL SPECIFICATIONS									
LOCATION										OMEGA_MK3B										ELECTRICALLY APPROVED BY									
										PROJECT										DRAWING NUMBER									
										OMEGA DEPOSITOR										079E25-00064									
										PROJECT										PAGE									
										OMEGA_MK3B										6 of 15									
																				REV									
																				A									

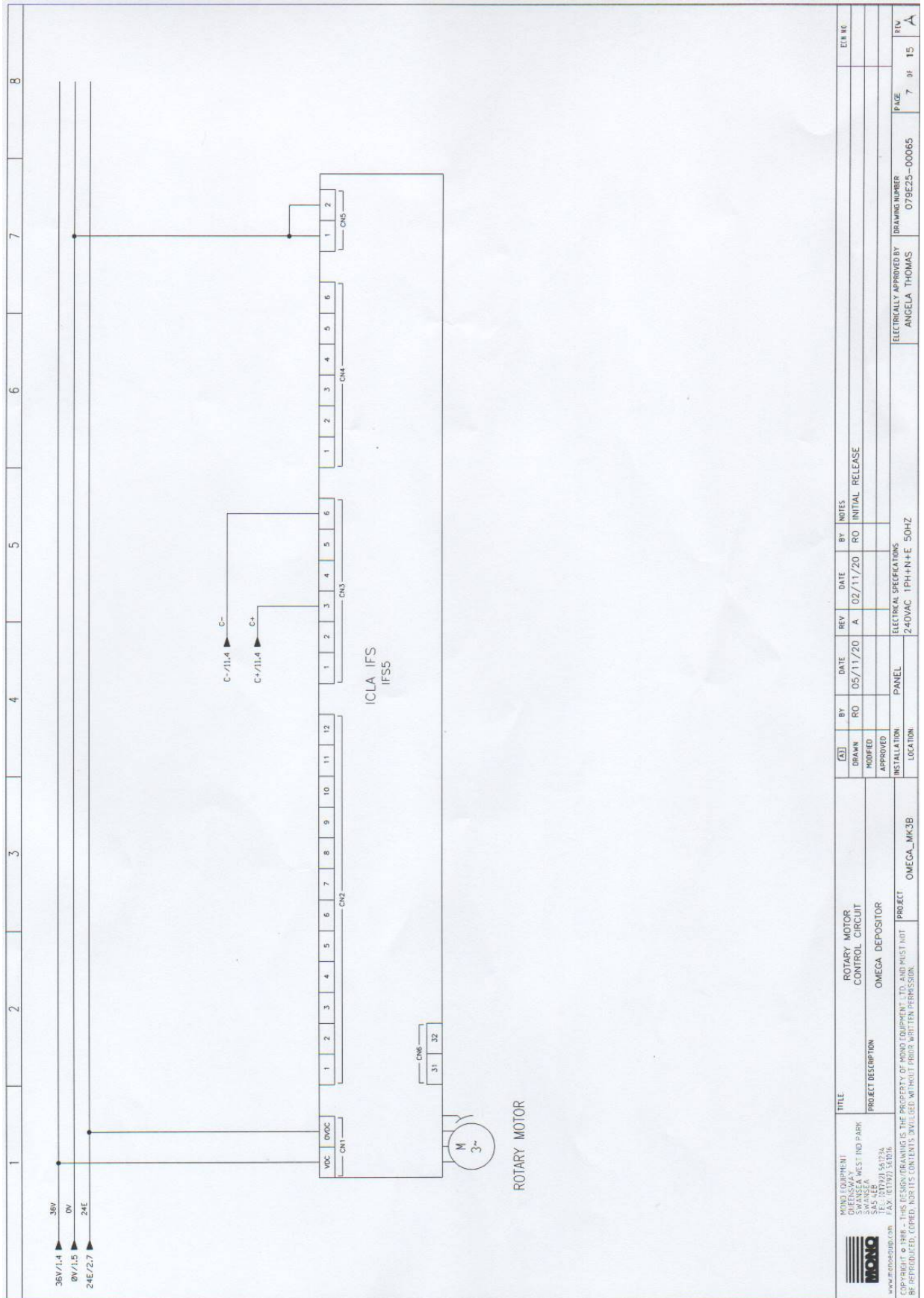

REV	DATE	BY	NOTES	INITIAL	RELEASE	DATE	BY	NOTES	INITIAL	RELEASE
A	02/11/20	RO	INITIAL							
	05/11/20	RO	DATE							

<p>MONO CORP/UNIT DRENSWAY SWANSEA WEST IND PARK S45 4EB TEL: 01792 541574 FAX: 01792 541010 www.monocorp.com</p>	<p>TITLE ROTARY MOTOR CONTROL CIRCUIT</p>	<p>PROJECT DESCRIPTION OMEGA DEPOSITOR</p>	<p>PROJECT LOCATION OMEGA_MK3B</p>
<p>COMPANY © 1996 - 2016. THIS DOCUMENT IS THE PROPERTY OF MONO EQUIPMENT LTD. AND MUST NOT BE REPRODUCED, COPIED, NOR ITS CONTENTS DIVULGED, WITHOUT PRIOR WRITTEN PERMISSION.</p>	<p>INSTALLATION: PANEL</p>	<p>ELECTRICAL SPECIFICATIONS 240VAC 1PH+N+E 50HZ</p>	<p>ELECTRICALLY APPROVED BY ANGELA THOMAS</p>
<p>DRAWN: RO</p>	<p>APPROVED:</p>	<p>LOCATION:</p>	<p>DATE: 02/11/20</p>
<p>BY: RO</p>	<p>DATE: 05/11/20</p>	<p>BY: RO</p>	<p>DATE: 02/11/20</p>
<p>INITIALS</p>	<p>DATE</p>	<p>INITIALS</p>	<p>DATE</p>

<p>DRAWING NUMBER 079E25-00065</p>	<p>PAGE 7 of 15</p>	<p>REV A</p>
--	-------------------------	------------------

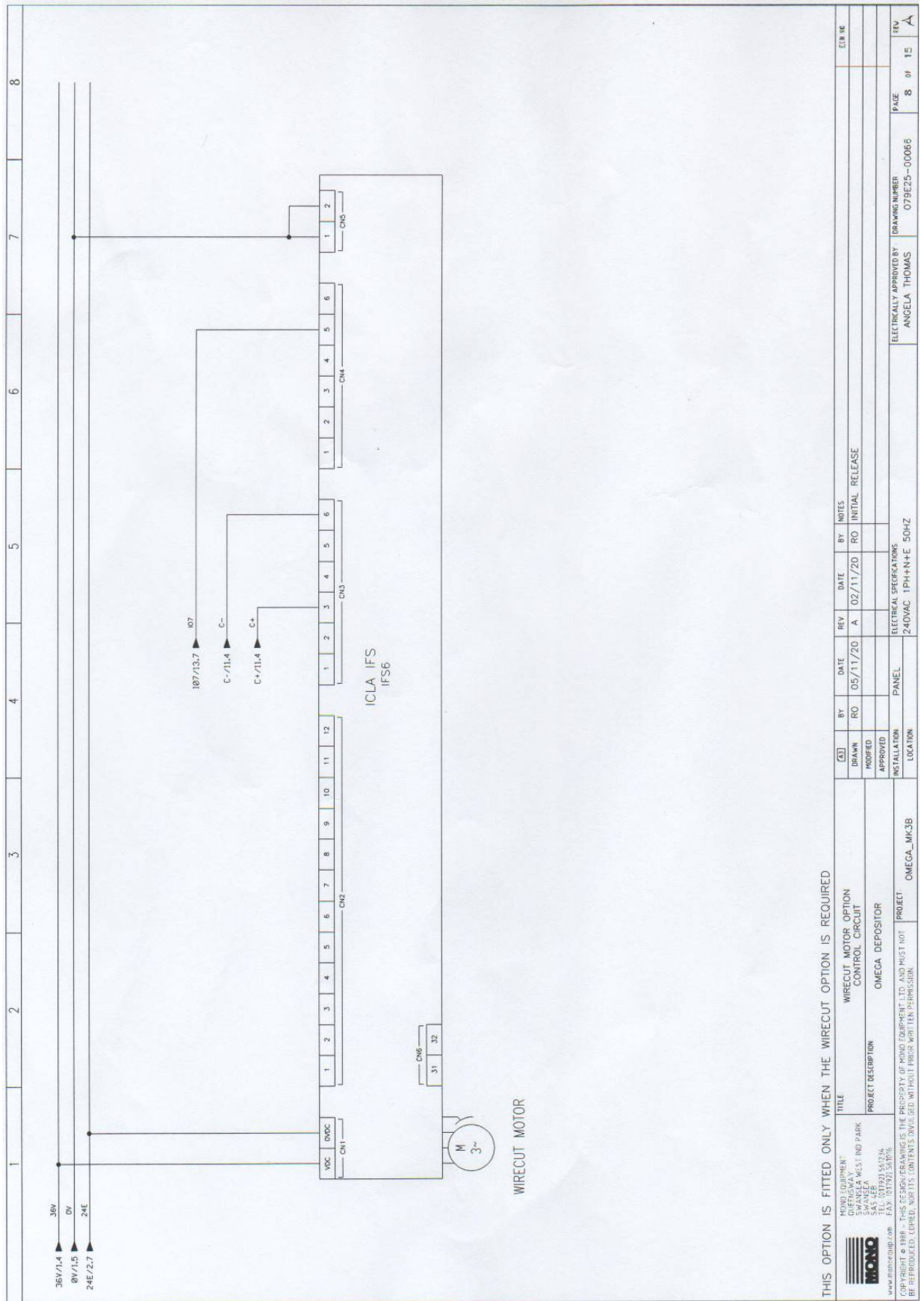

THIS OPTION IS FITTED ONLY WHEN THE WIRECUT OPTION IS REQUIRED

REV	DATE	BY	NOTES	INITIAL	RELEASE
A	02/11/20	RO	RO		

DESCRIPTION	DATE	BY	NOTES
WIRECUT MOTOR OPTION CONTROL CIRCUIT	05/11/20	RO	RO
OMEGA DEPOSITOR			

INSTALLATION LOCATION	ELECTRICAL SPECIFICATIONS	DRAWING NUMBER	PAUSE
OMEGA_MK3B	240VAC 1PH+N+E 50HZ	079E25-0006	8 of 15

NEW EQUIPMENT	TITLE	ENR NO
OMEGA DEPOSITOR	WIRECUT MOTOR OPTION CONTROL CIRCUIT	

PROJECT DESCRIPTION	PROJECT
OMEGA DEPOSITOR	OMEGA_MK3B

NEW EQUIPMENT
 OMEGA DEPOSITOR
 SWANSEA WEST IND PARK
 SWANSEA SA5 7EE
 TEL: 01792 540334
 FAX: 01792 540336
 WWW.OMEGA-UK.COM

COPYRIGHT © 1998 - THIS DOCUMENT REMAINS THE PROPERTY OF MORGAN EQUIPMENT LTD. AND MUST NOT BE REPRODUCED, COPIED, NOR ITS CONTENTS DIVULGED WITHOUT PRIOR WRITTEN PERMISSION.

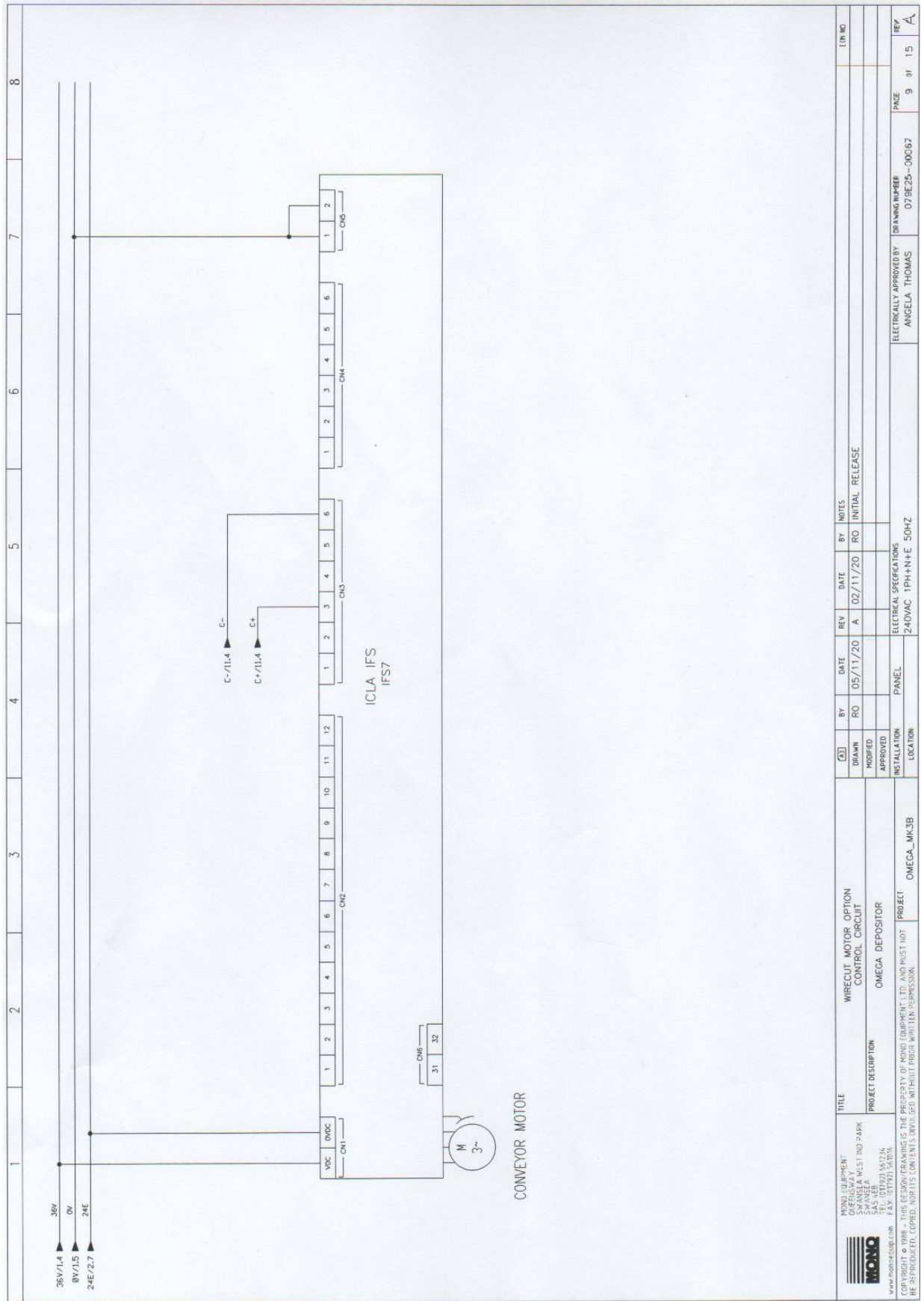

		NEW EQUIPMENT SWANSEA WEST IND PARK SWANSEA SA5 4EB TEL: 01792 54724 WWW.MONO.CO.UK		TITLE WIRECUT MOTOR OPTION CONTROL CIRCUIT		DATE 05/11/20		REV A		DATE 02/11/20		BY RO		NOTES INITIAL RELEASE		LINE 	
PROJECT DESCRIPTION OMEGA DEPOSITOR		PROJECT LOCATION OMEGA_MK3B		INSTALLATION PANEL		ELECTRICAL SPECIFICATIONS 240VAC 1PH+N+E 50HZ		ELECTRICALLY APPROVED BY ANGELA THOMAS		DRAWING NUMBER 07BE25-00067		PAGE 9 of 15		REV A			

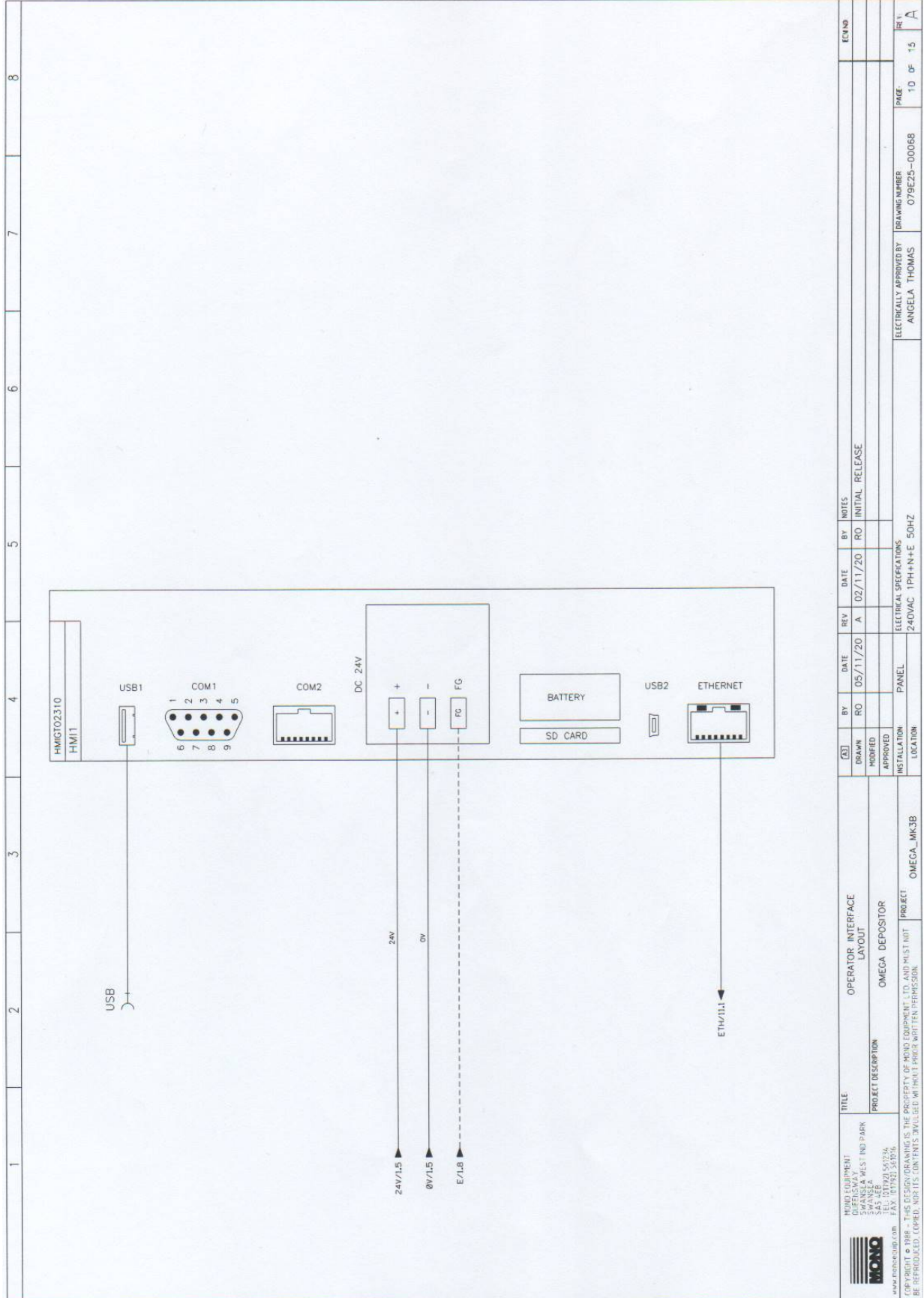

1 2 3 4 5 6 7 8

		TITLE HMI1 EQUIPMENT OPERATOR INTERFACE LAYOUT		DATE 05/11/20		REV A		DATE 02/11/20		BY RO		NOTES INITIAL RELEASE		ECAD	
SWANSEA WEST IND PARK SWANSEA SA5 2EB TEL: 01792 547074 FAX: 01792 547075 WWW.MONO.CO.UK		PROJECT DESCRIPTION OMEGA DEPOSITOR		INSTALLATION PANEL		ELECTRICAL SPECIFICATIONS 240VAC 1PH+N+E 50HZ		ELECTRICALLY APPROVED BY ANGELA THOMAS		DRAWING NUMBER 079E25-00068		PAGE 10 OF 15		REV A	

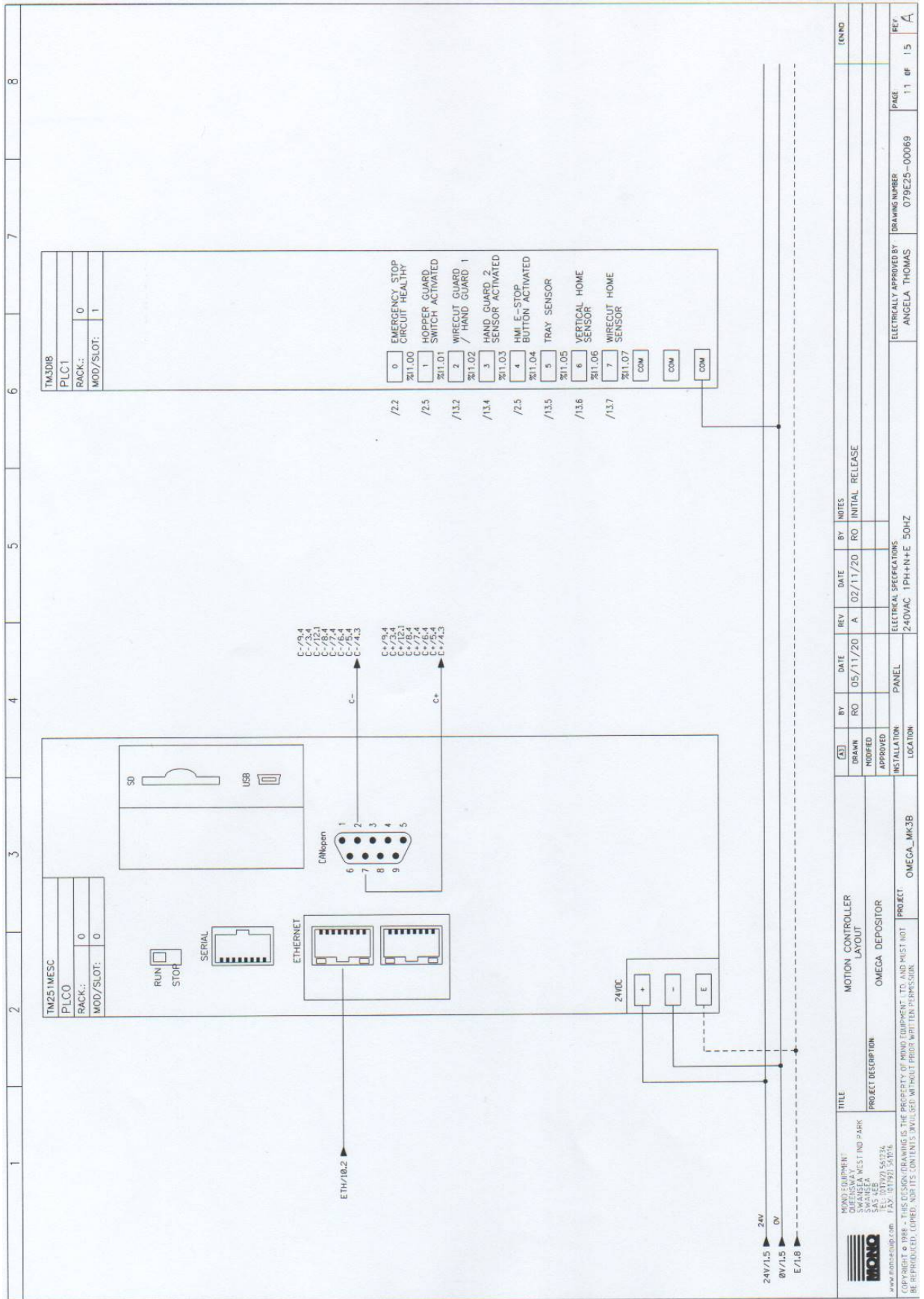

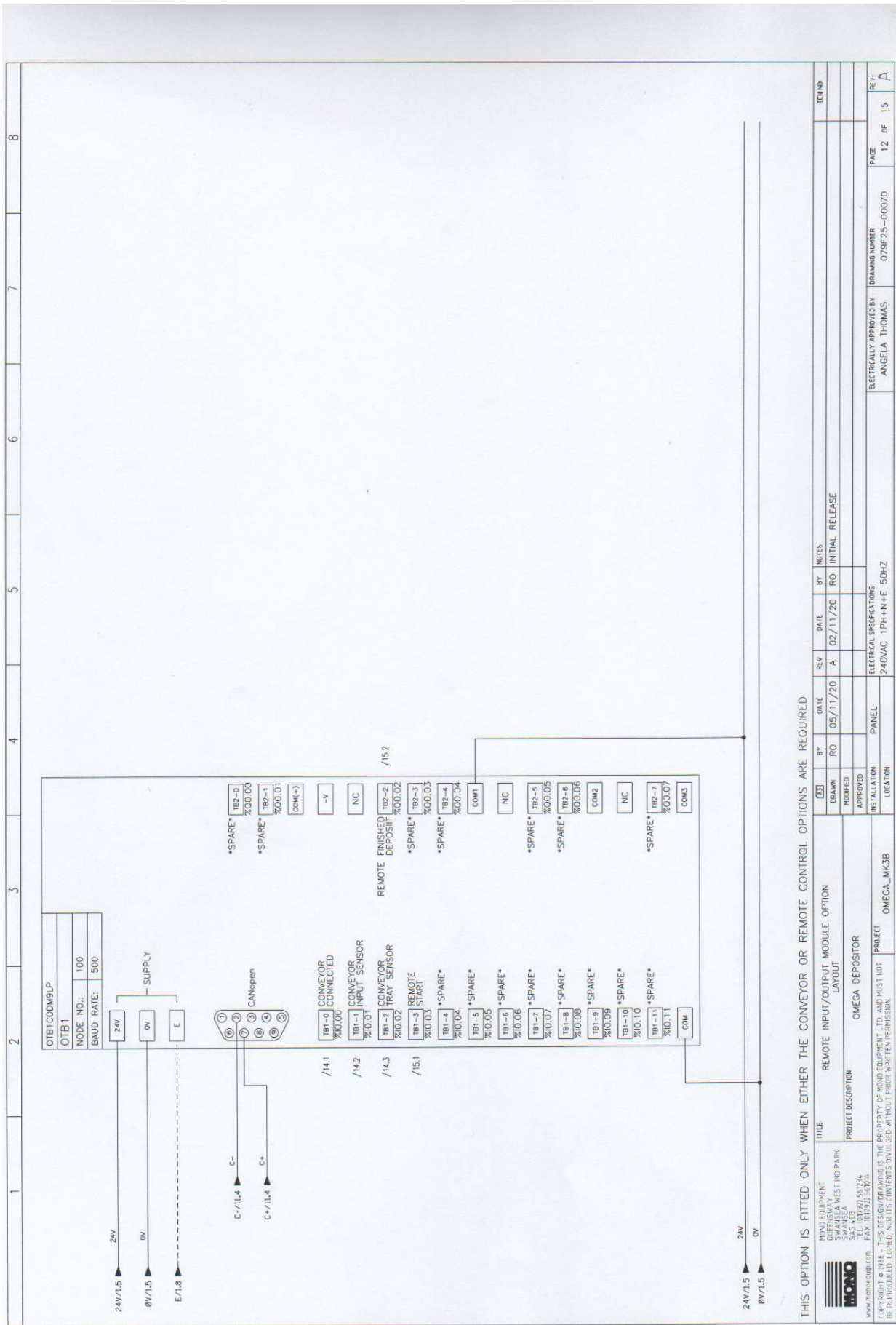

THIS OPTION IS FITTED ONLY WHEN EITHER THE CONVEYOR OR REMOTE CONTROL OPTIONS ARE REQUIRED

M&M ENGINEERING SWANSEA WEST IND PARK QUENSFERRY SA5 4EE SALES TEL: 01792 551034 FAX: 01792 361808 www.memecomp.com		TITLE REMOTE INPUT/OUTPUT MODULE OPTION LAYOUT		DATE 05/11/20		BY RO		DATE 02/11/20		BY RO		NOTES INITIAL RELEASE	
PROJECT DESCRIPTION OMEGA DEPOSITOR		INSTALLATION PANEL		ELECTRICAL SPECIFICATIONS 240VAC 1PH+N+E 50HZ		ELECTRICALLY APPROVED BY ANGELA THOMAS		DRAWING NUMBER 079E25-00070		PAGE 12 OF 15		REV A	

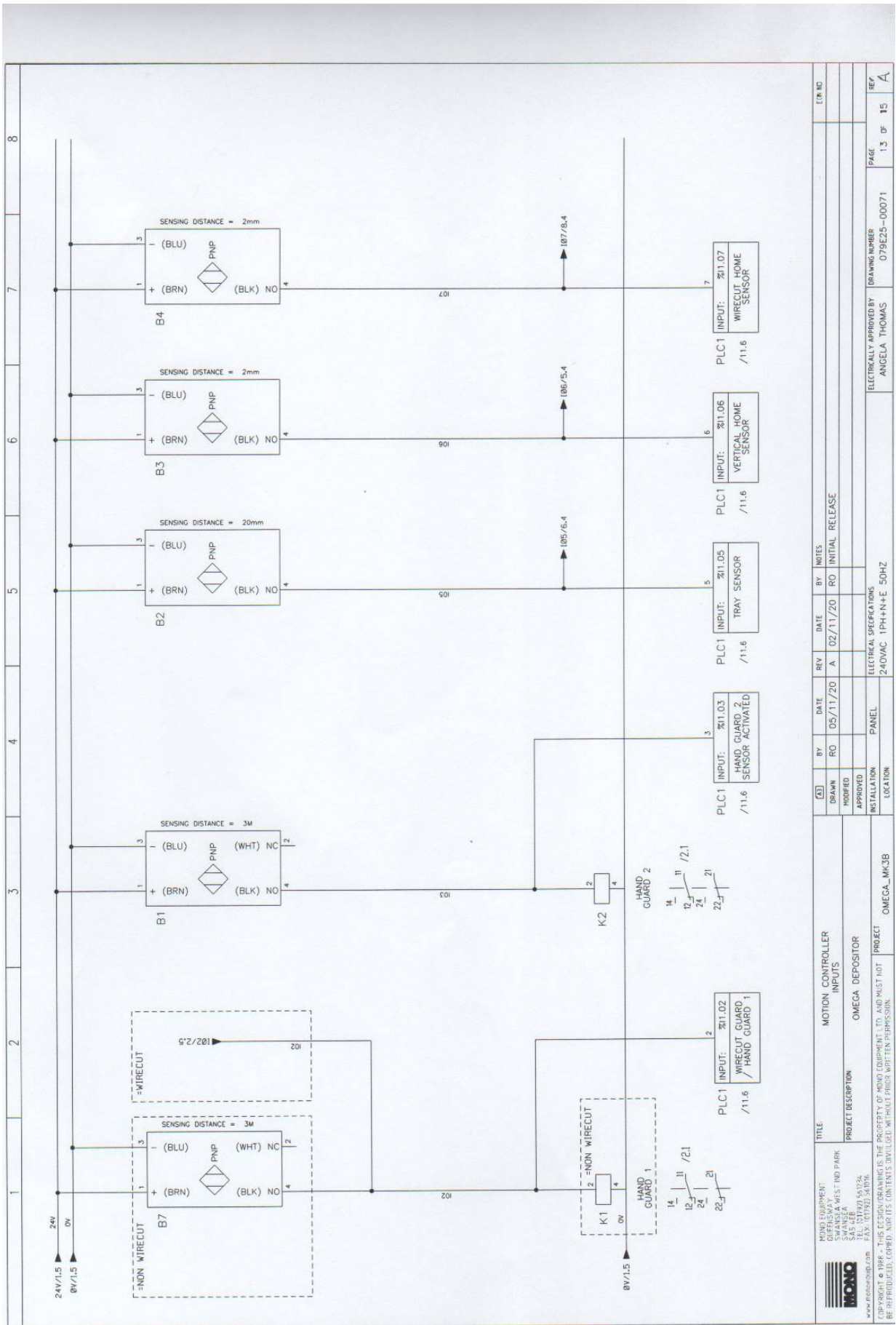

TITLE		MOTION CONTROLLER INPUTS		BY DATE		REV DATE		BY DATE		INITIAL RELEASE		ELECTRICAL SPECIFICATIONS		DRAWING NUMBER		PAGE		REV		
NEW EQUIPMENT SWANSEA WEST IND PARK QUERFARWAY SWANSEA SA5 4EE TEL: 01792 551734 FAX: 01792 261076 www.monobloc.com		PROJECT DESCRIPTION OMEGA DEPOSITOR		DR	05/11/20	RO	02/11/20	BY	RO	DATE	BY	RO	DATE	BY	RO	DATE	BY	RO	DATE	BY
PROJECT OMEGA_MK3B		PROJECT OMEGA DEPOSITOR		APPROVED		APPROVED		APPROVED		APPROVED		APPROVED		APPROVED		APPROVED		APPROVED		APPROVED
INSTALLATION LOCATION PANEL		INSTALLATION LOCATION PANEL		ELECTRICAL SPECIFICATIONS 240VAC 1PH+N+E 50HZ		ELECTRICAL SPECIFICATIONS 240VAC 1PH+N+E 50HZ		ELECTRICAL SPECIFICATIONS 240VAC 1PH+N+E 50HZ		ELECTRICAL SPECIFICATIONS 240VAC 1PH+N+E 50HZ		ELECTRICAL SPECIFICATIONS 240VAC 1PH+N+E 50HZ		ELECTRICAL SPECIFICATIONS 240VAC 1PH+N+E 50HZ		ELECTRICAL SPECIFICATIONS 240VAC 1PH+N+E 50HZ		ELECTRICAL SPECIFICATIONS 240VAC 1PH+N+E 50HZ		
ELECTRICALLY APPROVED BY ANGELA THOMAS		ELECTRICALLY APPROVED BY ANGELA THOMAS		ELECTRICALLY APPROVED BY ANGELA THOMAS		ELECTRICALLY APPROVED BY ANGELA THOMAS		ELECTRICALLY APPROVED BY ANGELA THOMAS		ELECTRICALLY APPROVED BY ANGELA THOMAS		ELECTRICALLY APPROVED BY ANGELA THOMAS		ELECTRICALLY APPROVED BY ANGELA THOMAS		ELECTRICALLY APPROVED BY ANGELA THOMAS		ELECTRICALLY APPROVED BY ANGELA THOMAS		
DRAWING NUMBER D79E25-00071		DRAWING NUMBER D79E25-00071		DRAWING NUMBER D79E25-00071		DRAWING NUMBER D79E25-00071		DRAWING NUMBER D79E25-00071		DRAWING NUMBER D79E25-00071		DRAWING NUMBER D79E25-00071		DRAWING NUMBER D79E25-00071		DRAWING NUMBER D79E25-00071		DRAWING NUMBER D79E25-00071		
PAGE 15		PAGE 15		PAGE 15		PAGE 15		PAGE 15		PAGE 15		PAGE 15		PAGE 15		PAGE 15		PAGE 15		
REV A		REV A		REV A		REV A		REV A		REV A		REV A		REV A		REV A		REV A		

Battery Replacement Procedure (M251 Motion Controller)



ONLY COMPETENT PERSONS TRAINED IN ELECTRICAL MAINTENANCE SHOULD ATTEMPT TO CARRY OUT THIS PROCEDURE. FAILURE TO OBSERVE SAFE WORKING PRACTICES AND FOLLOW THE INSTRUCTIONS IN THIS PROCEDURE COULD LEAD TO SERIOUS INJURY OR DEATH.

YOU MUST ISOLATE THE POWER SUPPLY BEFORE PROCEEDING.

YOU MUST WAIT FOR AT LEAST 10 MINUTES AFTER ISOLATION OF THE POWER SUPPLY BEFORE WORKING ON THE MACHINE.



Real Time Clock (RTC)

Overview

The M251 Logic Controller includes an RTC to provide system date and time information, and to support related functions requiring a real-time clock. To continue keeping time when power is off, a non-rechargeable battery is required (see reference below). A battery LED on the front panel of the controller indicates if the battery is depleted or absent.

This table shows how RTC drift is managed:

RTC Characteristics	Description
RTC drift	Less than 60 seconds per month without any user calibration at 25 °C (77 °F)

Battery

The controller has one battery.

In the event of a power interruption, the backup battery maintains the RTC for the controller.

This table shows the characteristics of the battery:

Characteristics	Description
Use	In the event of a transient power outage, the battery powers the RTC and user data.
Backup life	At least 2 years at 25 °C max (77 °F). At higher temperatures, the time is reduced.
Battery monitoring	Yes
Replaceable	Yes
Controller battery type	Lithium carbon monofluoride, type Panasonic BR2032

Installing and Replacing the Battery

While lithium batteries are preferred due to their slow discharge and long life, they can present hazards to personnel, equipment and the environment and must be handled properly.

DANGER

EXPLOSION, FIRE, OR CHEMICAL BURNS

- Replace with identical battery type.
- Follow all the instructions of the battery manufacturer.
- Remove all replaceable batteries before discarding unit.
- Recycle or properly dispose of used batteries.
- Protect battery from any potential short-circuit.
- Do not recharge, disassemble, heat above 100 °C (212 °F), or incinerate.
- Use your hands or insulated tools to remove or replace the battery.
- Maintain proper polarity when inserting and connecting a new battery.

Failure to follow these instructions will result in death or serious injury.

To install or replace the battery, follow these steps:

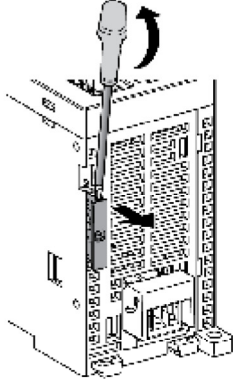
Step	Action
1	Remove power from your controller.
2	Use an insulated screw-driver to pull out the battery holder. 
3	Slide out the battery holder of the controller

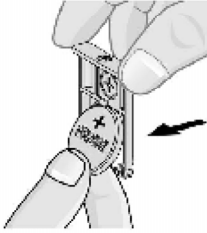
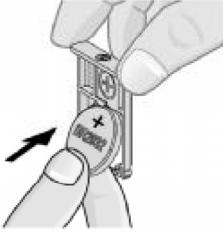
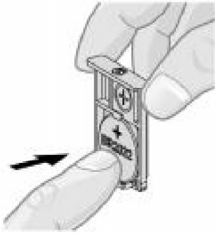
Step	Action
4	Remove the battery from the battery holder. 
5	Insert the new battery into the battery holder in accordance with the polarity markings on the battery. 
6	Replace the battery holder on the controller and verify that the latch clicks into place. 

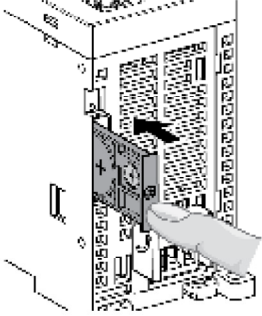
Step	Action
7	Slide in the battery holder of the controller. 
8	Power up your M251 Logic Controller.
9	Set the internal clock. For further details on the internal clock, refer to M251 Logic Controller Programming Guide (see <i>Modicon M251 Logic Controller, Programming Guide</i>).

NOTE: Replacement of the battery in the controllers other than with the type specified in this documentation may present a risk of fire or explosion.

 **WARNING**

IMPROPER BATTERY CAN PROVOKE FIRE OR EXPLOSION

Replace battery only with identical type: Panasonic Type BR2032.

Failure to follow these instructions can result in death, serious injury, or equipment damage.

The equipment mentioned in this manual has CE accreditation.

As it is our policy to improve our machines continuously, we reserve the right to change specifications without prior notice



Queensway,
Swansea West Industrial Estate,
Swansea.
SA5 4EB
UK

Tel. +44(0)1792 561234 | Spares +44(0)1792 564039

Email: marketing@monoequip.com

Website: www.monoequip.com