

MonoEquip.com

Enter **Serial No.** here. _____

In the event of an enquiry please quote this serial number.

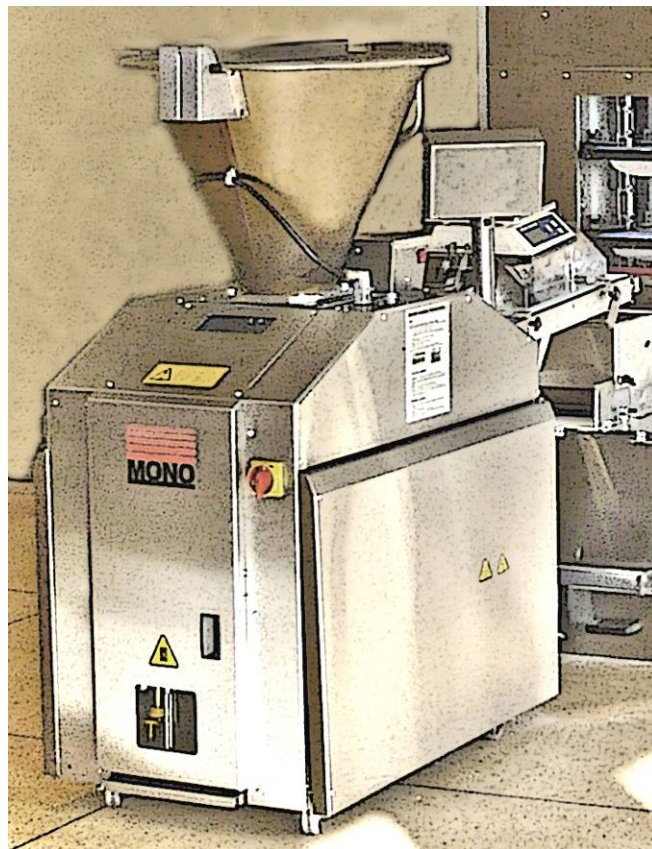

**FULL OPERATING AND MAINTENANCE
MANUAL
FOR THE
STAND ALONE DIVIDER**

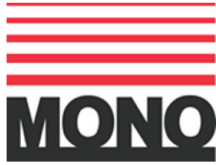

DECLARATION OF CONFORMITY

We hereby declare that this machine complies with the essential health and safety requirements of :-

- The Machinery Directive 2006 / 42 / EC
- The Low voltage Directive 2006 / 95 / EC
- The requirements of the Electromagnetic Compatibility Directive 2004 / 108EC, 91 / 263 / EEC, 92 / 31 / EEC
- The General Safety of Machinery and food processing Standards applicable
- Materials and Articles intended to come into contact with food - Regulation (EC) No. 1935 / 2004
- Good manufacturing practice for Materials intended to come into contact with food - Regulation (EC) No. 2023 / 2006

Signed	
D. Osmundsen – Quality and Conformance Manager	

Date	
-------------	--

Machine FG Code.		Machine Serial No.	
-----------------------------	--	-------------------------------	--

A technical construction file for this machine is retained at the following address:

MONO EQUIPMENT
Queensway,
Swansea West Industrial Park,
Swansea
SA5 4EB
UK

MONO EQUIPMENT is a business name of **AFE GROUP Ltd**
Registered in England No.3872673 VAT registration No.923428136

Registered office: Unit 35,
Bryggen Road,
North Lynn Industrial Estate,
Kings Lynn Norfolk,
PE30 2HZ

IMPORTANT NOTES

SAFETY SYMBOLS

This manual and other product documentation (available at www.monoequip.com) use the following safety symbols.

Before using your new equipment, read the instruction manual carefully and pay special attention to information marked with the following symbols.



WARNING

Indicates a hazardous situation which, if not avoided, will result in electric shock.



WARNING

Indicates a hazardous situation which, if not avoided, will result in death or serious injury.



CAUTION

Indicates a hazardous situation which, if not avoided, will result in minor or moderate injury.



ELECTRICAL SAFETY AND ADVICE REGARDING SUPPLEMENTARY ELECTRICAL PROTECTION

Commercial kitchens and food service areas are environments where electrical appliances may be located close to liquids or operate in and around damp conditions or where the restricted movement for installation and service is evident.

The installation and periodic inspection of the appliance should only be undertaken by a qualified, skilled and competent electrician, and connected to the correct power supply suitable for the load as stipulated by the appliance data label.

The electrical installation and connections should meet the necessary requirements of the local electrical wiring regulations and any safety guidelines.

We recommend:-

- Supplementary electrical protection with the use of a Residual Current Device (RCD)
- Fixed wiring appliances should also incorporate a locally situated switch disconnecter to connect to, which is easily accessible for switching off and safe isolation purposes. The switch disconnecter must meet the specification requirements of IEC 60947.

Your attention is drawn to:-

BS 7671:2018 – Guidance Note 8 – 8.13: Other locations of increased safety risk

It is recognised that there may be locations of increased risk of electrical shock other than those specifically addressed in Part 7 of BS 7671. Examples of such locations could include laundries where there are washing and drying machines in close proximity and water is present, and commercial kitchens with stainless steel units, where once again, water is present. Where, because of the perception of additional risks being likely, the installation designer decides that an installation or location warrants further protective measures, the options available includes:

- Automatic Disconnection of Supply (ADS) by means of a residual current device having a residual operating current not exceeding 30 mA;
- Supplementary protective equipotential bonding; and
- Reduction of maximum fault clearance time.

The provision of RCDs and supplementary bonding must be specified by the host organisation's appointed installation designer or electrical contractor and installed by a suitably qualified and competent electrician so as to comply with Regulations 419.2 and 544.2.



The supply to this machine must be protected by a **30mA Type A RCD**.

- ❑ **FAILURE TO KEEP TO THE CLEANING AND MAINTENANCE INSTRUCTIONS DETAILED IN THIS MANUAL COULD AFFECT THE WARRANTY and SAFETY OF THIS MACHINE**

NOTE --- DIVIDER OIL

DO NOT USE ORDINARY VEGETABLE OIL FROM SHOP SHELVES, IN THE DIVIDER.

*THIS WILL FORM A GUM-LIKE RESIDUE,
CAUSING STICKING AND POSSIBLE DAMAGE TO THE MACHINE.*

MONO RECOMMENDS THE USE OF “**CRODA SUPER WUNDROL**”
(AVAILABLE FROM MONO. **PART NUMBER “A900-25-272”**)

CONTENTS – DOUGH DIVIDER

1.0 Introduction	page 7
2.0 General Dimensions	page 8
3.0 Specifications	page 8
4.0 Safety	page 9
5.0 Installation	page 10
6.0 Isolation	page 12
7.0 Cleaning Instructions	page 13
• Daily	page 13
• Weekly	page 17
8.0 Operating Machine	page 18
9.0 Maintenance	page 21
10.0 Troubleshooting	page 23
11.0 Spares and Service Information	page 24
12.0 Electrical Information Section	page 25
13.0 DIVIDER LOCATOR KIT INSTALLATION GUIDE	page 29

1.0 INTRODUCTION

THE MONO DIVIDER is accurate, reliable and compact.

- ❑ It has a large capacity hopper, simple controls and adjustments.
- ❑ The in-line discharge gives a very compact machine.
- ❑ The dough divider has the capacity to accurately scale dough pieces, Between 8oz (250g) and 36 oz (1000g).

THE DIVIDING PROCESS

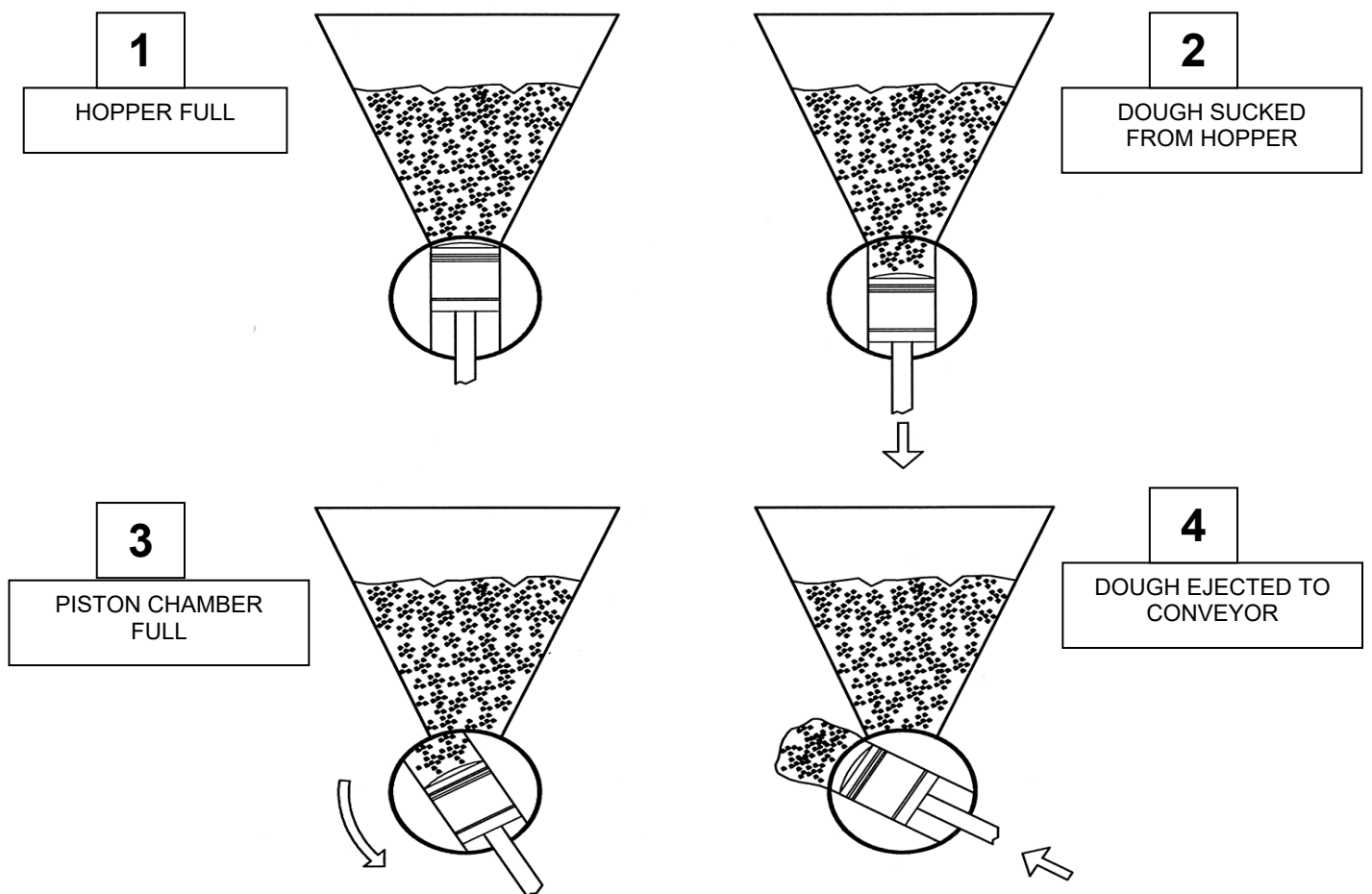

NOTE

THE DIVIDER WORKS ON VOLUME NOT WEIGHT.

2.0 GENERAL DIMENSIONS

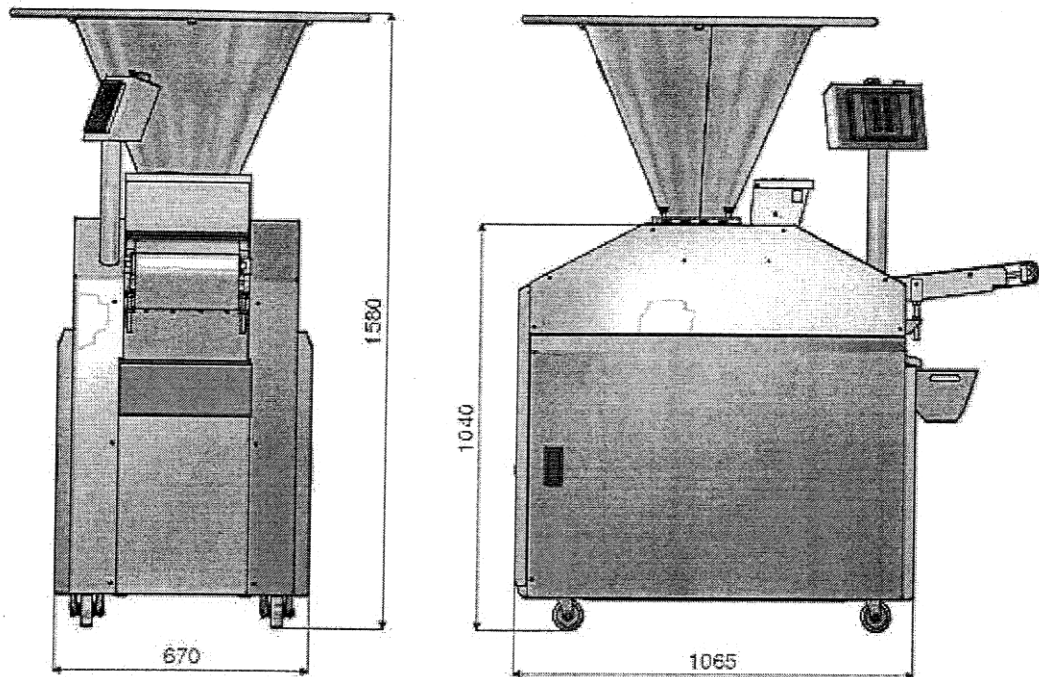

Height: 1580mm.

Depth: 1065mm. (inc. conveyor 1900mm)

Width: 670mm.

3.0 SPECIFICATIONS

Total power: 3.2kW, three phase + N + E, 415v /50Hz



The supply to this machine must be protected by a **30mA Type A RCD**

Capacity: Accurately scaled dough pieces,
between 250g and 1000g (8oz - 36oz).

Weight: 500kg.

Noise Level: Less than 85dB.

4.0 SAFETY

- 1 **Never use a machine in a faulty condition** and always report any damage.
- 2 **Only trained engineers may remove any part** that requires a tool to do so.
- 3 **People undergoing training on the machine must be under direct supervision** of a fully trained person.

- 4 **Use of the machine can prove dangerous if:**



- The machine is operated by untrained or unskilled staff
- The machine is not used for its intended purpose
- The machine is not operated correctly



- 5 **Always ensure hands are dry before touching any electrical appliance** (Including cable, switches and plugs).

- 6 **Do not operate the machine with any panels or guards removed.**

- ***All safety devices applied to the machine during manufacture and the operating instructions in this manual are required to operate this machine safely. The owner and the operator are responsible for operating this machine safely.***



- ***DO NOT TRY TO DISABLE ANY SAFETY DEVICES, THEY ARE FITTED FOR YOUR SAFETY.***

- 7 **NEVER** move machinery by pulling on the power cords or cables.

- 8 **No loose clothing or jewellery** should be worn while operating the machine

- 9 **The bakery manager or the bakery supervisor must carry out daily safety checks** on the machine.

- 10 **No one under the age of 16 may operate** this machine.

- 11 **No-one under the age of 18 may clean** this machine under any circumstances.



- 12 **DO NOT STAND ON ANYTHING TO LOAD THE DIVIDER HOPPER.**



WARNING:
NEVER LEAVE MACHINE WITH DOUGH IN
AS PRESSURES BUILD UP AS THE DOUGH PROVES.



ALL CLEANING AND MAINTENANCE OPERATIONS MUST BE MADE WITH THE DIVIDER DISCONNECTED FROM THE POWER SUPPLY.

5.0 INSTALLATION



DO NOT ATTEMPT TO LIFT THE DIVIDER BY HUMAN FORCE

- ❑ Use of a **forklift or crane** is recommended for lifting, or the machine can be pushed into position on the castors provided.
- ❑ **To lift with a forklift** the machine must be secured to a pallet.
- ❑ **To lift with a crane**, lifting eyes are provided when the main side sheeting has been removed

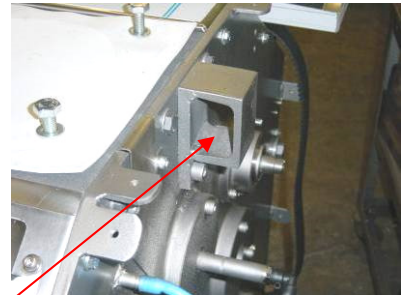
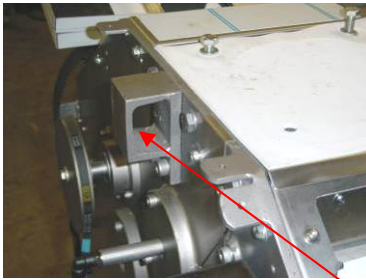

LIFTING EYES

Check that the power rating on the serial number plate matches the supply that the machine is to be connected to.

IF USED WITH A BREAD PLANT

- ❑ The Dough Divider should be connected to the location socket on the prover drive box front.
- ❑ Connect the divider to the correct position with the prover and insert keeper pin to hold.

DIVIDER POWER SOCKET



DIVIDER BODY

DIVIDER CONNECTER PIN

If the divider is to be fitted to a Mono prover that has not had the locator fitted, please see locator kit fitting instructions at the end of this manual.

- ❑ Connect the electrical cable to the power socket on the wall. If being used as part of a bread plant , connect to the socket on the prover drive box front.
- ❑ Check machine after installation to ensure the belt moves in the correct direction indicated (see arrow in photo below).

*(If wrong - swap positions of any two of the three phase carrying wires in the plug.
With a plant this should be factory set and not need to be done)*

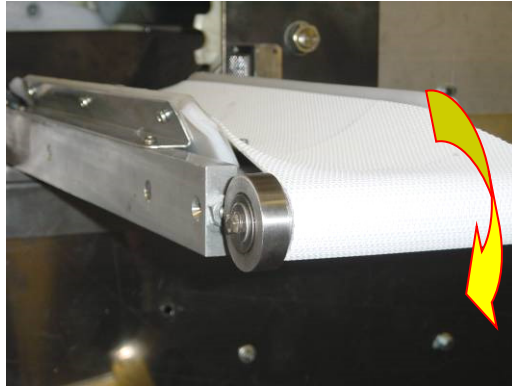

- ❑ Fill oil tank to 2/3 level, with your company recommended food safe oil.

NOTE.

**DO NOT USE ORDINARY VEGETABLE OIL FROM SHOP SHELVES, IN THE DIVIDER
THIS WILL FORM A GUM-LIKE RESIDUE,
CAUSING STICKING AND POSSIBLE DAMAGE TO THE MACHINE.
MONO RECOMMENDS THE USE OF “CRODA SUPER WUNDROL”
(AVAILABLE FROM MONO. PART NUMBER “A900-25-272”)**

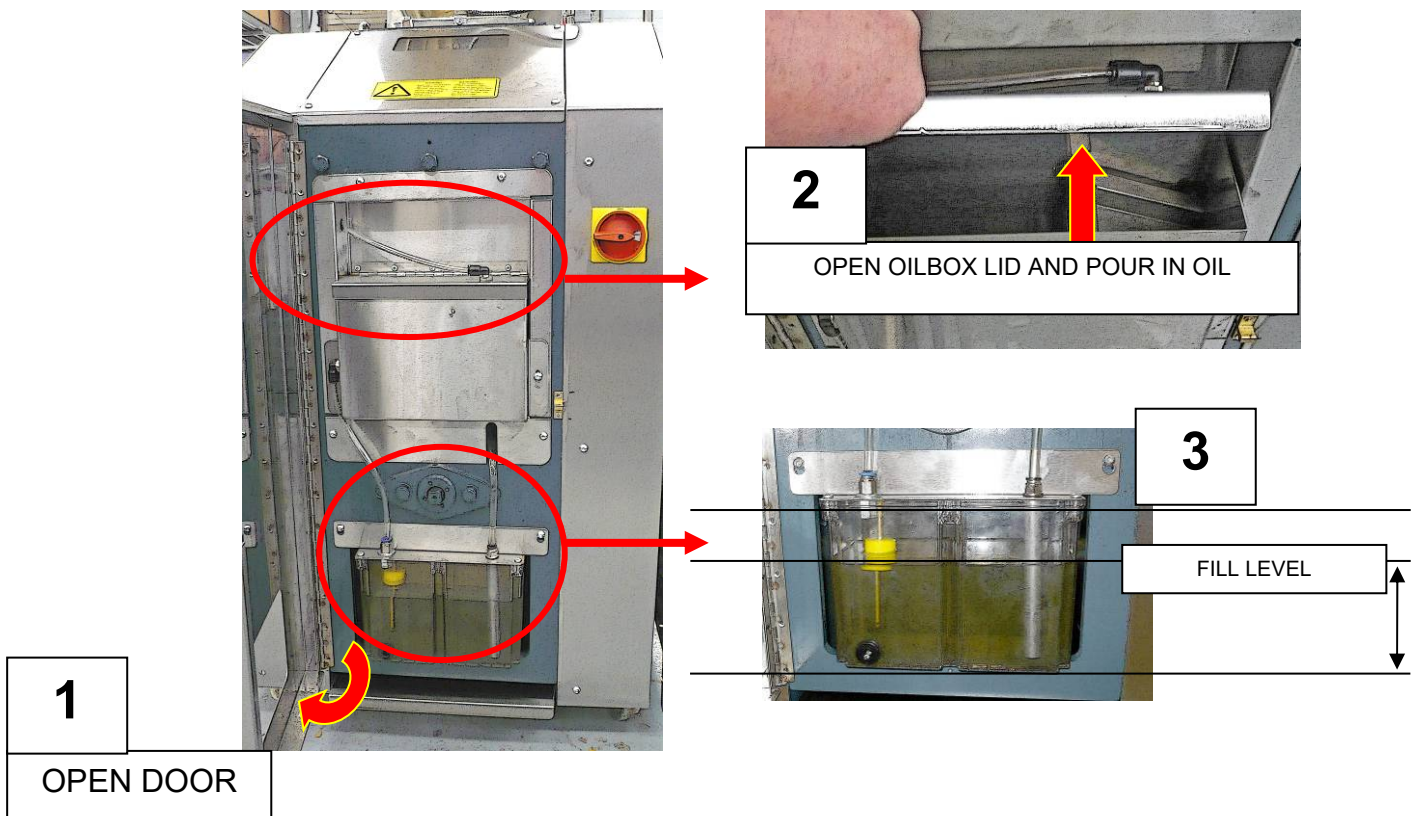

6.0 ISOLATION

TO STOP THE DOUGH DIVIDER IN AN EMERGENCY,
Switch off at the MAIN ISOLATOR or EMERGENCY BUTTON

DIVIDER MAIN ISOLATOR



The DIVIDER EMERGENCY STOP BUTTON.



**EMERGENCY STOP BUTTON
(TWIST TO RELEASE)**



7.0 CLEANING INSTRUCTIONS

DAILY



NOTE:

ISOLATE MACHINE FROM POWER SUPPLY BEFORE CLEANING.

- CLEANING SHOULD ONLY BE CARRIED OUT BY FULLY TRAINED PERSONNEL
- DO NOT USE A HIGH PRESSURE WASHER
- DO NOT USE SOLVENTS OF ANY KIND
- KEEP CLEANING FLUIDS AWAY FROM ELECTRICAL SWITCHES

1 Remove the dough residue from interior of the hopper.
(Only use **plastic scraper**)

2 Smear interior of the hopper with divider oil.

1 Check oil level is correct. (see next page).

Then run the machine for a minute, using on/off buttons.
(*This will stop the machine from seizing up by coating the drum with oil*)

NOTE:

**THE ABOVE STEPS MUST BE FOLLOWED DAILY,
OTHERWISE IT WILL LEAD TO THE BUILD UP OF STARCH
AND SEIZURE OF THE MACHINE.**

OIL LEVEL CHECKING

- Fill oil tank to 2/3 level, with your company recommended food safe oil.

○ **NOTE!**

DO NOT USE ORDINARY VEGETABLE OIL FROM SHOP SHELVES, IN THE DIVIDER
*THIS WILL FORM A GUM-LIKE RESIDUE,
CAUSING STICKING AND POSSIBLE DAMAGE TO THE MACHINE.*

MONO RECOMMENDS THE USE OF “CRODA SUPER WUNDROL”
(AVAILABLE FROM MONO. PART NUMBER “A900-25-272”)

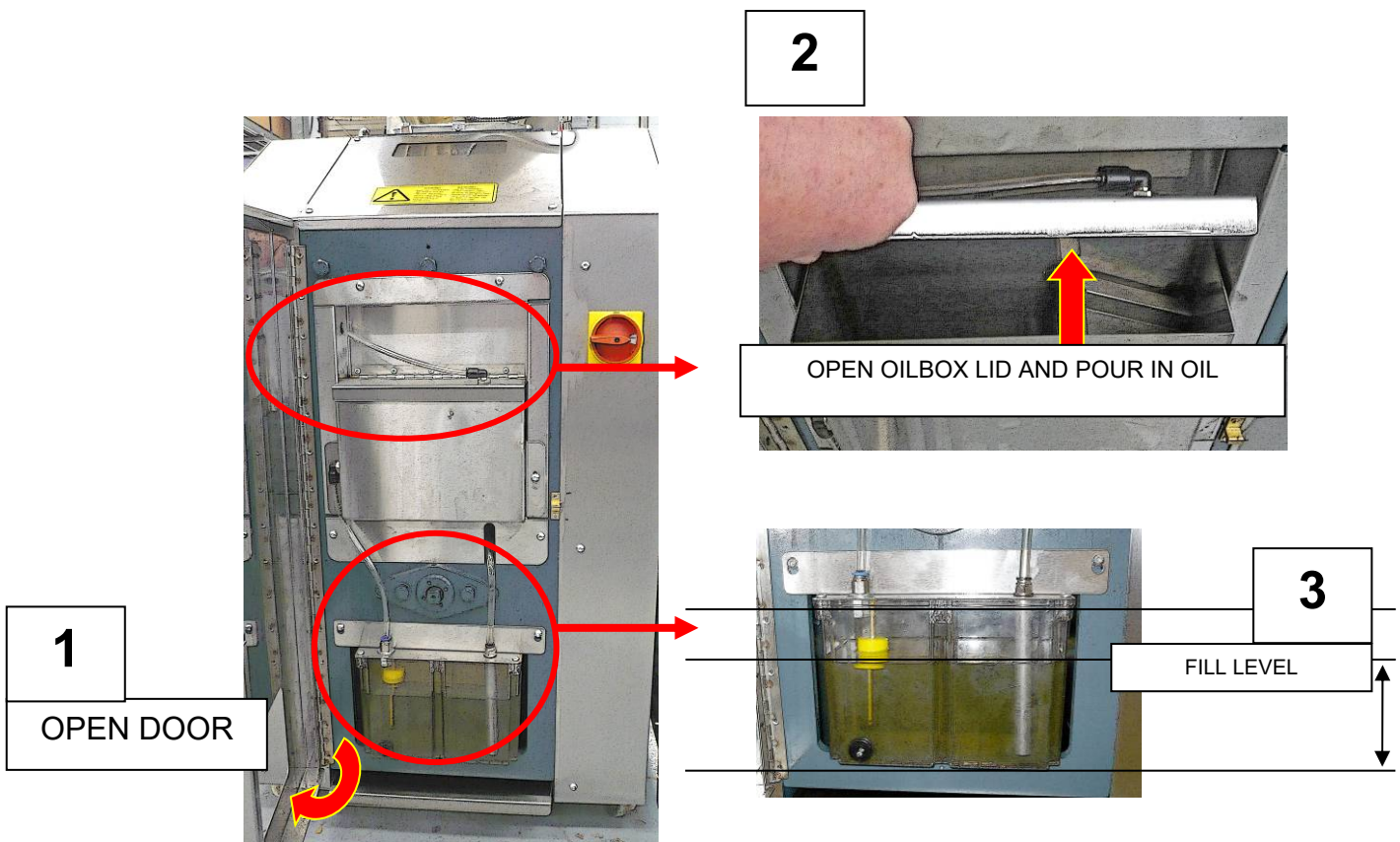

❑ OFF TAKE CLEANING

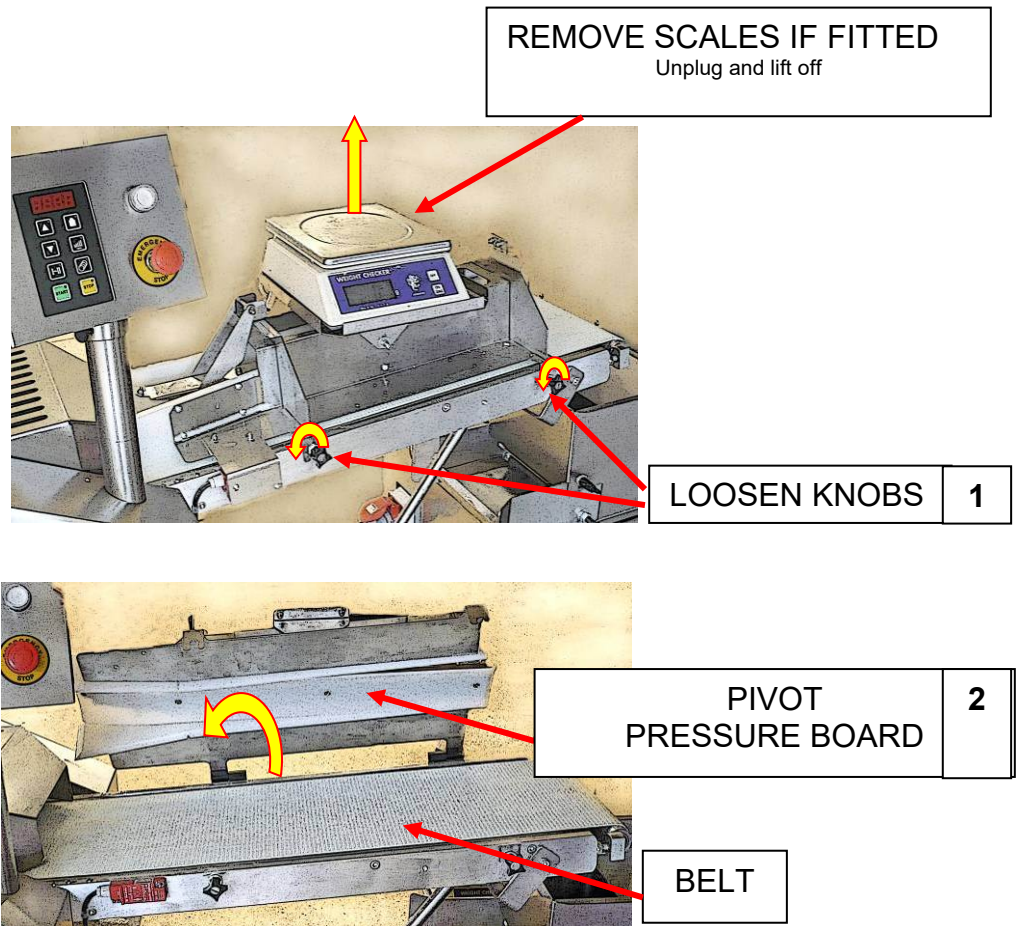

- 1 Unplug and remove the scales.
- 2 Loosen the two black knobs on the side of the pressure board.
- 3  Pivot the pressure board away from you.
Help may be required to hold the pressure board while cleaning takes place.
- 4 Remove any dough residue and brush exposed parts.
- 5 Scrape and wipe down the belt. (Only use **plastic scraper**).
- 6 Remove any dough residue from the conveyor metal work and belt surface.
- 7 Lower the pressure board and tighten the two black knobs on the side of the pressure board.
- 8 Replace and plug in the scales.

□ **EXTERNAL CLEANING**

- 1 Brush off any flour residue and scrape as necessary. (Only use **plastic scraper**)
- 2 Brush off loosened dough.
- 3 Make up sterilising solution and hot water.
- 4 Clean the exterior of the divider as necessary, working from top to bottom.
- 5 Swab dry with disposable tissue.

□ **UNDER CONVEYOR COLLECTION BOX**

- 1 Brush the chute debris into the collection box.

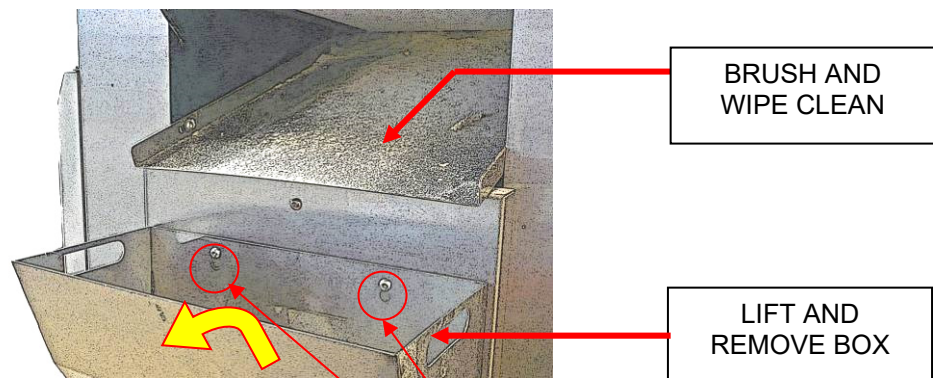

- 2 Lift and remove the collection box and clean.

- 3 Replace the collection box, making sure it is pushed right down on locating screws.

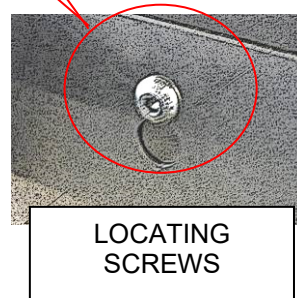

WEEKLY

NOTE:

CLEANING SHOULD ONLY BE CARRIED OUT BY FULLY TRAINED PERSONNEL



**WARNING:
ISOLATE MACHINE FROM MAINS SUPPLY**

1. Scrub wheels with a small nylon cleaning brush or scouring pad and hot water sterilising solution.
- 2 Clean entire exterior surfaces of the machine working from top to bottom.

8.0 OPERATING

- 1 Check divider is connected to a power supply.
- 2 Check that the hopper is clear of objects and Smear interior with divider oil.

NOTE!

DO NOT USE ORDINARY VEGETABLE OIL FROM SHOP SHELVES, IN THE DIVIDER
*THIS WILL FORM A GUM-LIKE RESIDUE,
CAUSING STICKING AND POSSIBLE DAMAGE TO THE MACHINE.*

MONO RECOMMENDS THE USE OF "CRODA SUPER WUNDROL"
(AVAILABLE FROM MONO. PART NUMBER "A900-25-272")

CONTROL POD BUTTONS

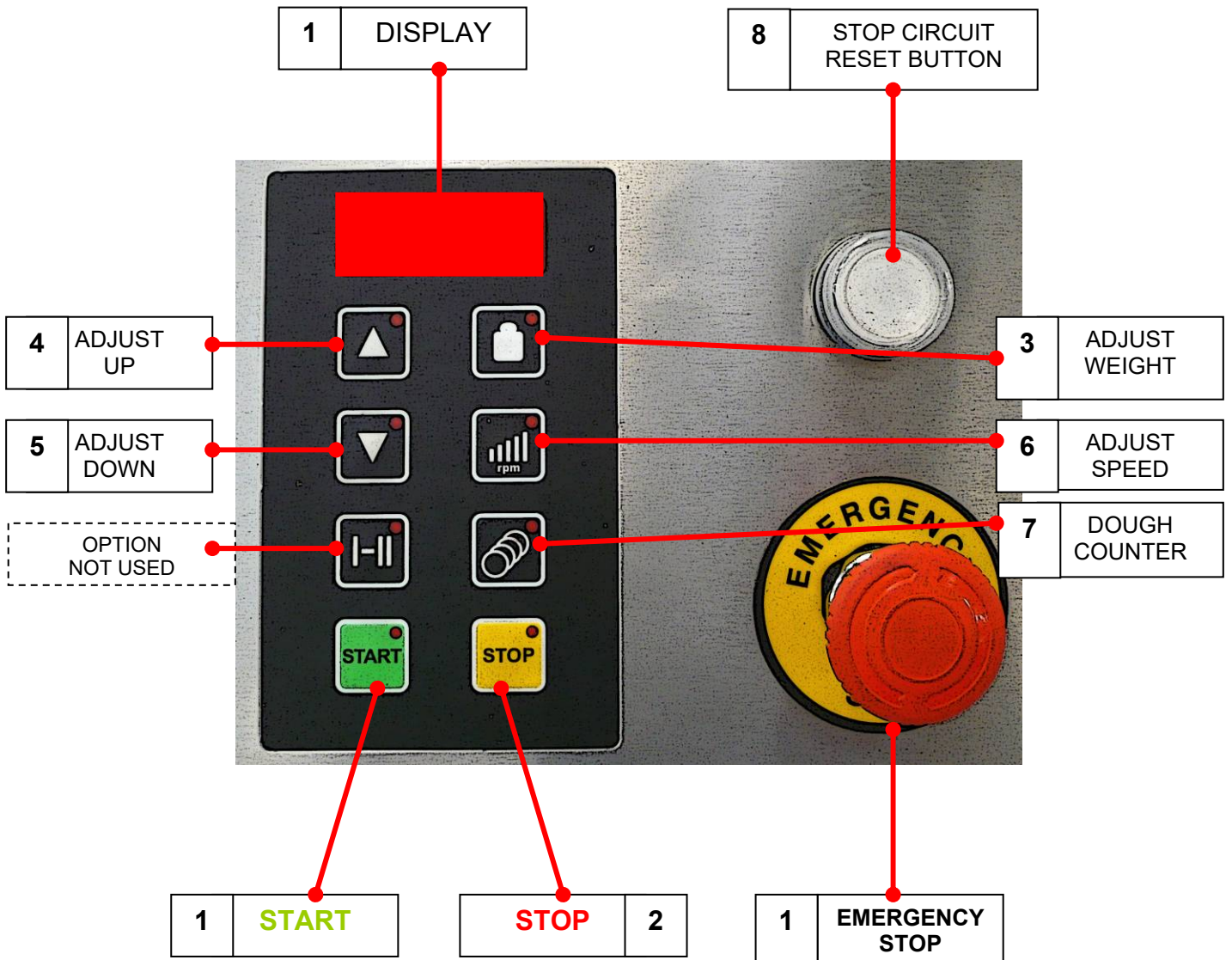

- 3 Run the divider for two minutes to allow oil to circulate. (Press “START” (1))
Then Stop the divider. (Press “STOP” (2))

Note: *To prevent contamination, It is advisable to thoroughly check the hopper and off take conveyor for traces of a previous dough.*

- 4 Load dough into the hopper.
- 5 Run the machine (Press “START” (1)) and check the first dough pieces out of the discharge conveyor for weight and cleanliness.

Adjust weight by pressing the “weight adjust button” (3) and then use the “adjust up” button (4) or the “adjust down” button (5) to alter the weight.

Make a note of the number showing in the display window for future reference.

(NOTE the number is only a reference to the setting and is not an indicator of weight, size etc.)

(REPLACE CLEAN DOUGH INTO THE HOPPER. DO NOT PUT BACK ON CONVEYOR)

Normally the first six dough pieces are put back into the hopper, as weight consistency is suspect in the initial dough pieces.

If any dough pieces are contaminated with excess oil or traces of previous doughs e.g. Wholemeal, discard accordingly.

- 6 Run dough through the divider.
Care must be taken with weights, especially towards the end of a batch of dough.
Check weigh at regular intervals.
- 7 Check the oil level in the tank frequently throughout shift and top up, if required.

Be aware that dough is a “live” product and will expand in size during the dividing process so check weigh adjustments will have to be made during a batch of dough.

Note: - *The divider is a volume divider that divides by size of dough piece, not by weight.*



WARNING! NEVER LEAVE DIVIDER WITH DOUGH INSIDE, AS PRESSURES CAN BUILD UP AS THE DOUGH PROVES

FLOUR DUSTER OPERATION

TO ENSURE AN EVEN FLOW, ONLY USE CLEAN, DRY FLOUR.



DUSTER LOCATION

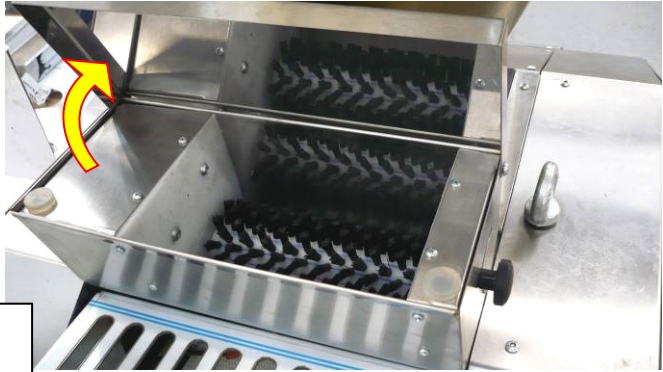

1

OPEN LID AND FILL WITH DRY FLOUR,
THEN CLOSE THE LID



2

TURN ON POWER WHEN REQUIRED



3

ADJUST THE FLOW BY LOOSENING THE
BLACK KNOB AND MOVING TO THE
REQUIRED POSITION. RETIGHTEN KNOB.

9.0 MAINTENANCE

General maintenance



WARNING ■ ISOLATE DIVIDER FROM MAINS SUPPLY BEFORE ATTEMPTING ANY MAINTENANCE OPERATIONS.



WARNING ■ This appliance must be maintained at regular intervals. The frequency of maintenance will depend upon your specific use and location. The maximum service interval should be 12 months.

- Service and maintenance should only be undertaken by suitably qualified, trained, and competent engineers.
- You must immediately report any damage or defect arising with the appliance.
- Unsafe equipment is dangerous. Do not use the appliance. Isolate the power supply and contact **MONO** or your appointed service agent.

Due to the low maintenance design of the divider, maintenance consists of the operations in the cleaning section and a few of the following checks:

- Conveyor belt adjustment (as required).
- condition and greasing (check monthly)
- Weight adjuster chain condition and greasing (check monthly)

Conveyor Belt Adjustment

Conveyor belt should be no tighter than necessary to eliminate slippage. Over tensioning can lead to belt and/or bearing failure. The belt should be adjusted by means of the adjustment tensioning nuts.

The belt should run with equal clearance between its edges and the conveyor unit side frames. If one edge of the belt is tighter than the other, it will tend to run towards the slack side. This tracking defect can be eliminated by individual adjustment of the tensioning nuts.

ADJUSTMENT NUTS
(each side)

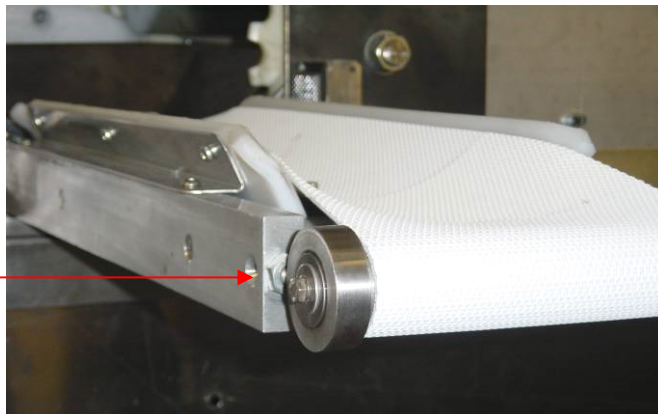

- Open the side panels. (Remove 2 fixing screws each side and swing open).
- **Chain greasing**
Check that the chains are clean and greased.

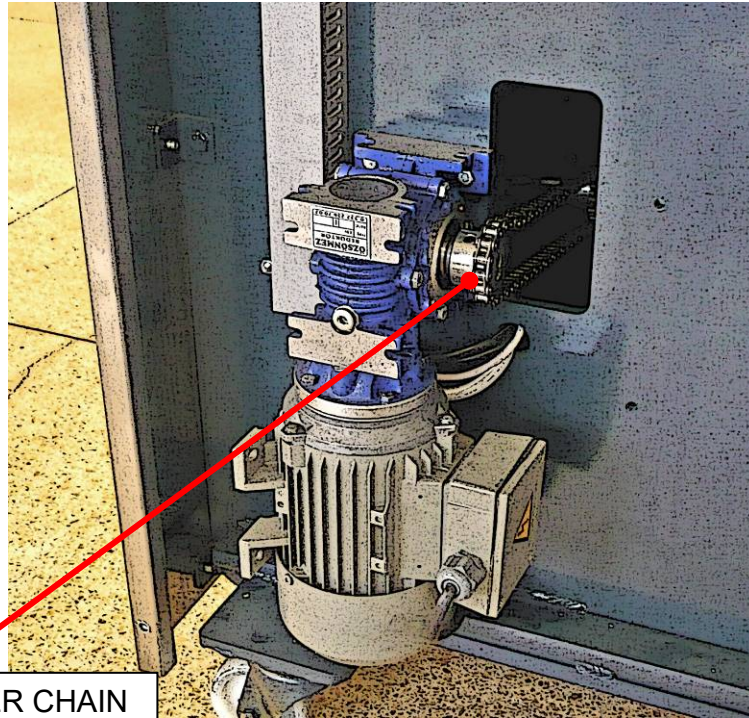

WEIGHT ADJUSTER CHAIN

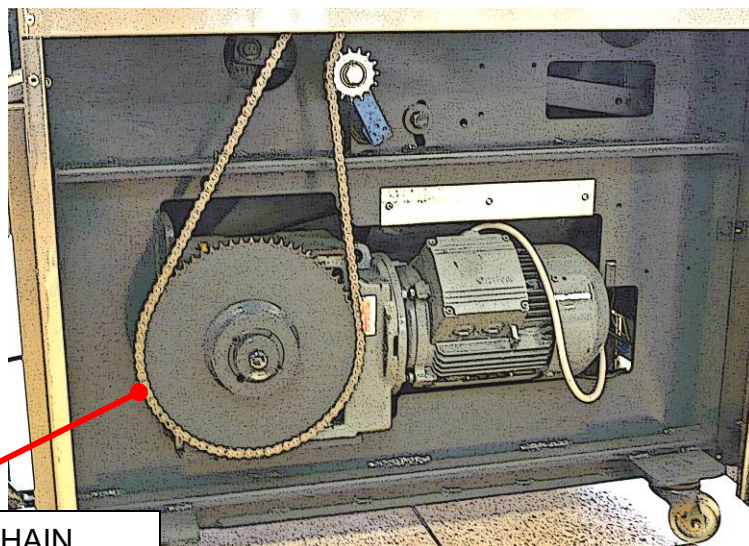

MAIN DRIVE CHAIN

10.0 TROUBLESHOOTING

Divider does not run

- **Check power is turned on at the isolator on the wall**
*If part of a bread plant check that the plant is connected and turned on.
Check plug into intermediate prover is correctly connected.*
- **Check all safety switches are operating (hopper closed etc.).**
- **Check a red “stop button” is not depressed (Turn to release.) and stop circuit reset button (8) has been pressed.**



WARNING: IF THERE IS ANY POSSIBILITY OF DAMAGE TO PLUG OR LEAD, ISOLATE DIVIDER FROM PROVER BEFORE CHECKING.

- If divider still does not function after carrying out these checks, call out “Mono” service dept.
(see next page)

11.0 SPARES AND SERVICE ---

If a fault arises, please do not hesitate to contact the Customer Service Department, quoting the **machine serial number** on the silver information plate of the machine.

SPARES and OVERSEAS SUPPORT:

MONO

Queensway
Swansea West Industrial Estate
Swansea. SA5 4EB UK

email: spares@monoequip.com
www.monoequip.com

Spares Tel. +44(0)179256403

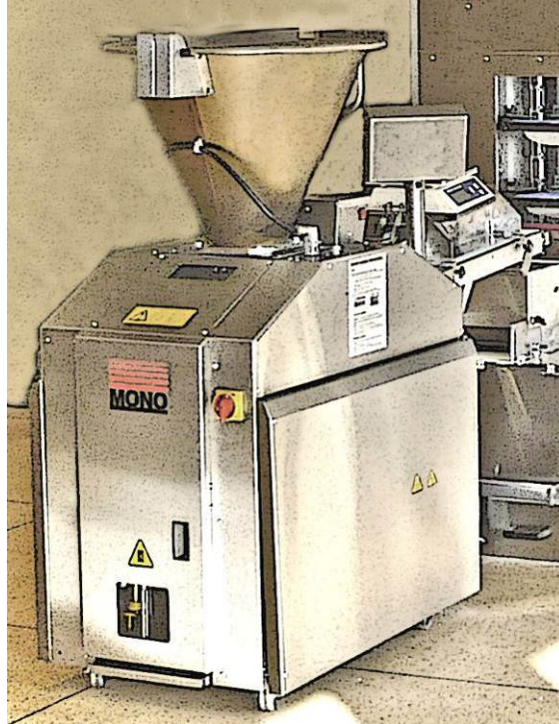

12.0 ELECTRICAL INFORMATION SECTION



NOTE

Due to continual improvements this section may not be correct for your model.
Please contact MONO before using.

ELECTRICAL DISTRIBUTION

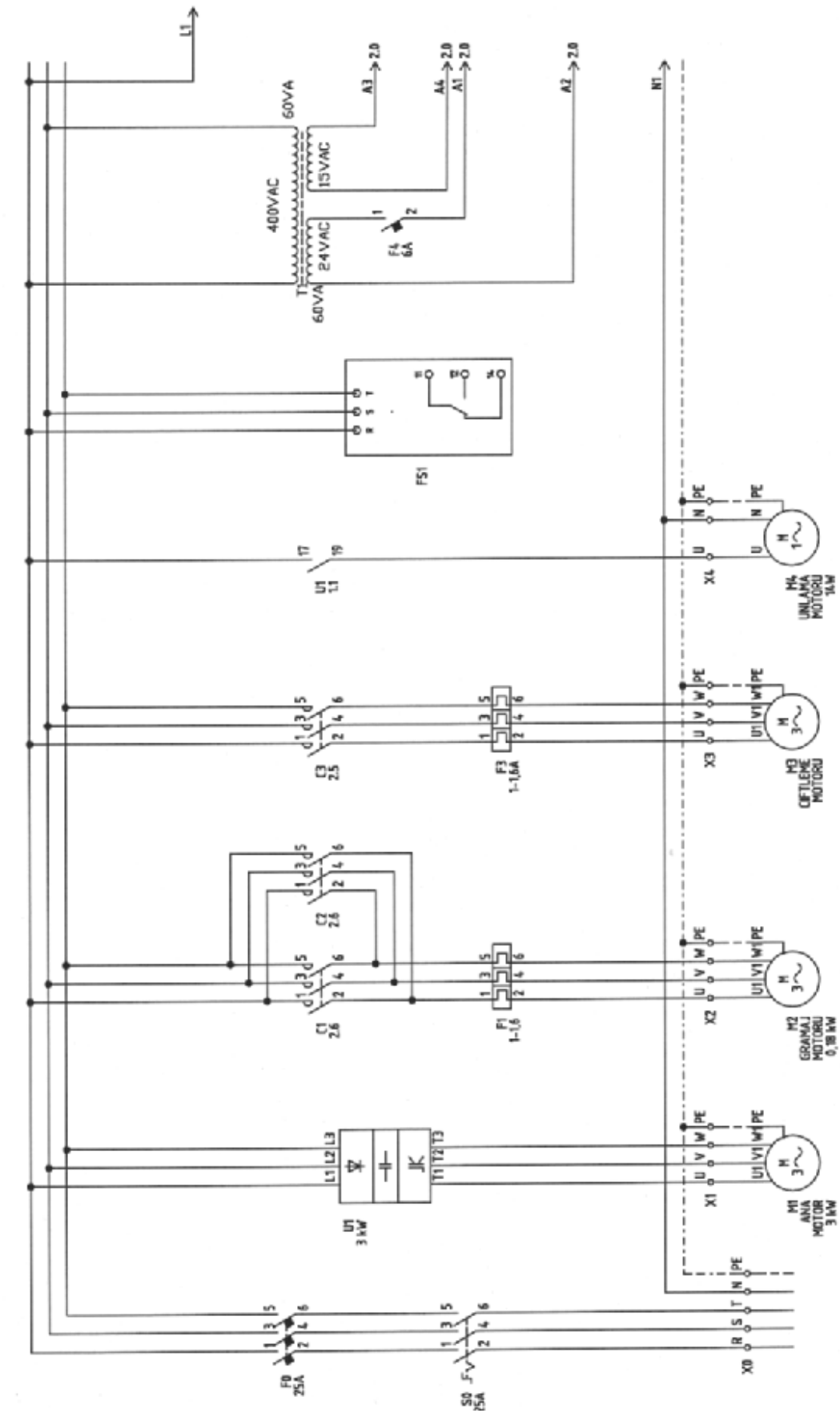

CONTROL CIRCUIT

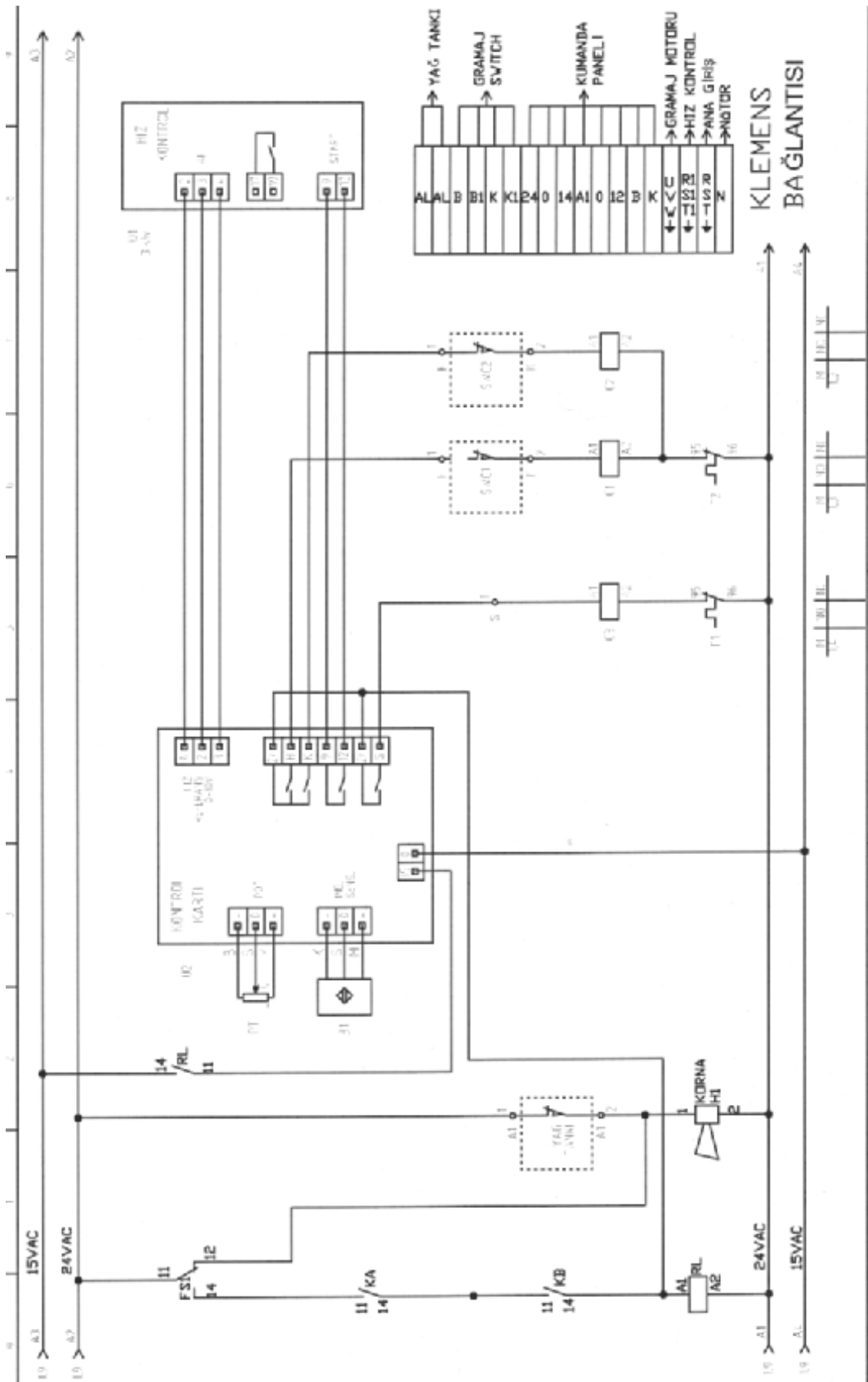

EMERGENCY STOP MONITORING CIRCUIT

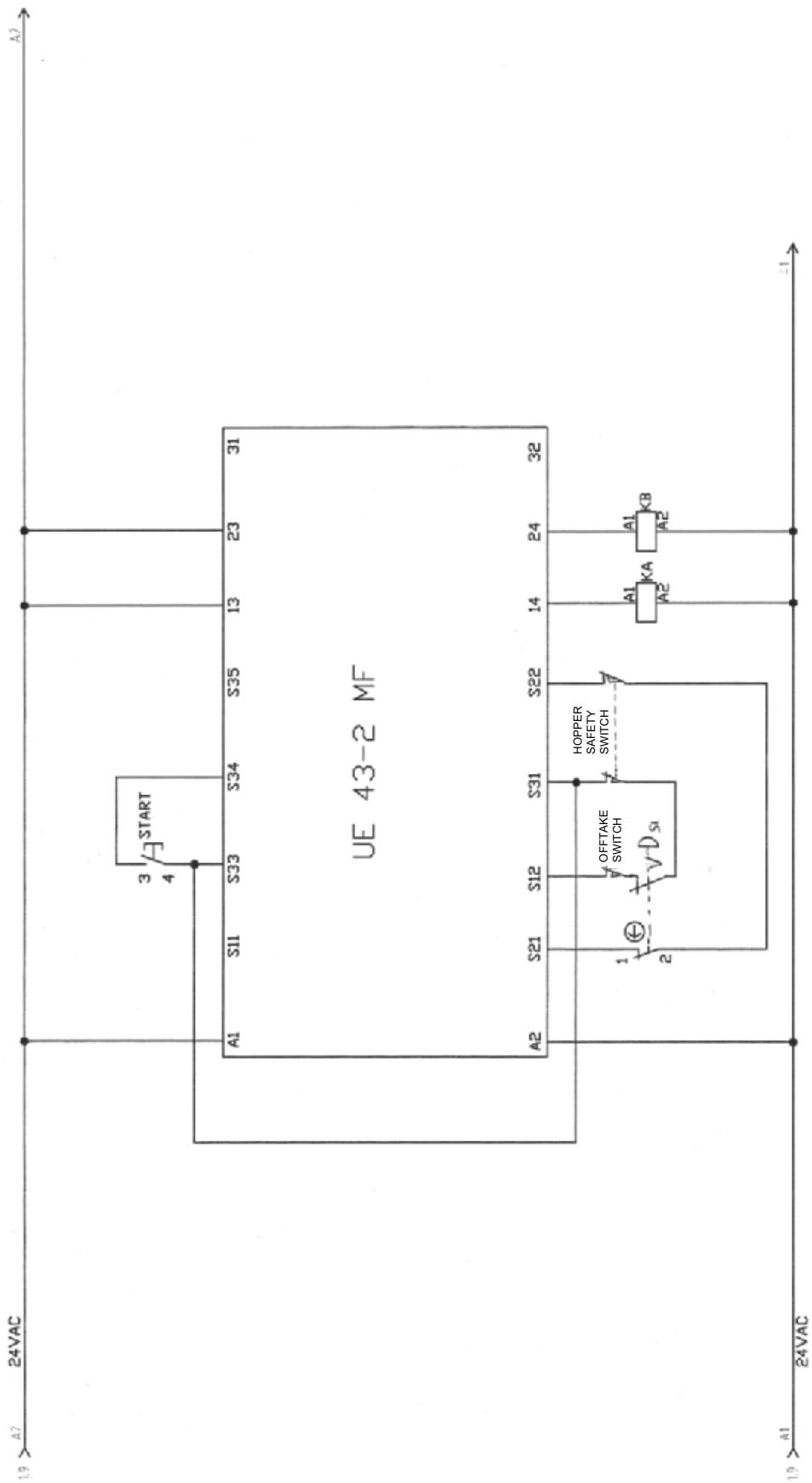

INSTALLATION GUIDE - FG398 DIVIDER TO FG036 PROVER

Parts list:

- 036-00-75500 Dough drawer (with cut-out)
- M036-KMB017 Universal Divider Locator Kit
- 036-07-21100 infeed chute extender
- 036-07-21200 Deflector
- B872-22-054 Circuit breaker-type C60HD-310

Fig. 1

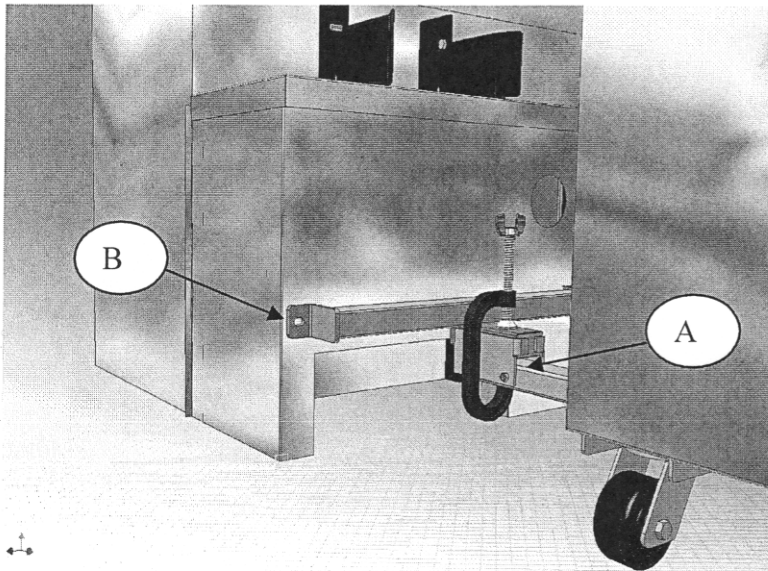

Referring to (Fig. 1):
After having assembled the locator kit to the required configuration (R/H or L/H). Securely clamp the two locators together, having first inserted 8 – 10mm thick packing where shown at 'A'. This is important to ensure adequate working clearance when in service.

Position the divider with locator against the prover drive box ensuring that the dimension shown at 'B' is roughly equal at both sides of the drive box. Mark through the slots in preparation for drilling. Drill $\text{Ø } 10,5 \text{ mm}$ through the outer sheet, angle iron frame and motor plate. Bolt the divider locator to the prover drive box using the bolts supplied. It is possible to do this by working through the dough drawer aperture and without removing any prover sheeting. However, it is easier if the bolts are inserted from inside the machine with the nuts on the outside.

Fig. 2

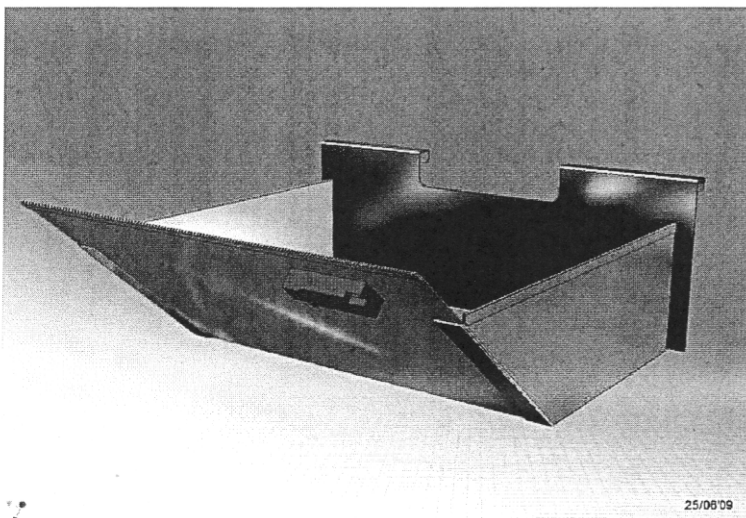

The dough drawer is supplied without holes for the safety switch magnetic actuator. Therefore, it will be necessary to copy the hole positions from the old dough drawer. Mark off and drill the holes, remove the magnetic actuator from the old dough drawer and fit to the new one.

Fig. 3

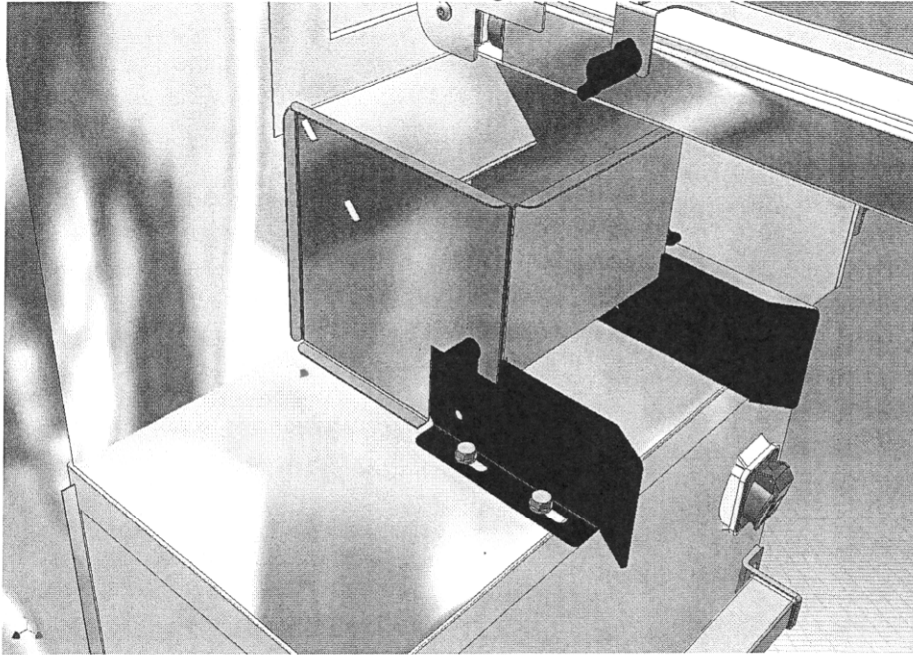

Assemble the two parts of the infeed chute extender and fit to the existing divider locator as shown in fig. 3, noting that it is secured using the original plastic wing nuts. Also note that the original divider retainers should be discarded.

Fig. 4

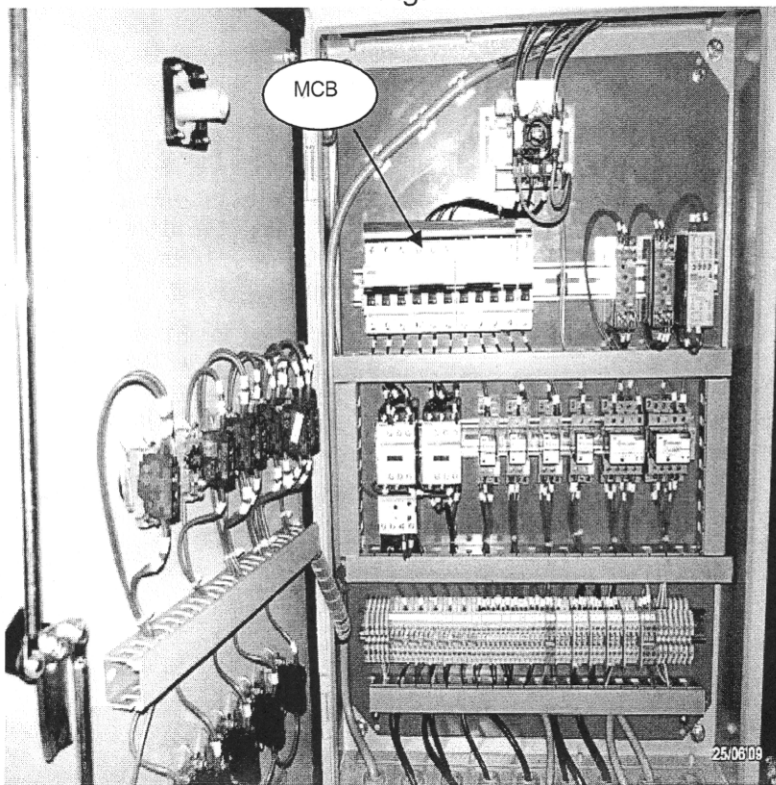

Working inside the electrical control panel (Fig.4), identify the MCB which supplies the divider socket and change this for one of 10 Amp capacity (supplied)

Briefly test-run the divider to check for correct rotation of the conveyor drive motor and alter the appropriate cables if necessary. (Later dividers have a phase sequence indicator which sounds an audible alarm if the phase rotation is incorrect)

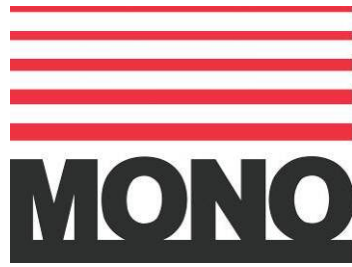

Queensway
Swansea West Industrial Estate
Swansea,
SA5 4EB, UK

email: spares@monoequip.com
www.monoequip.com
Tel. +44/0 1792 561234

Spares Tel. +44/0 1792 564039

DISPOSAL

CARE SHOULD BE TAKEN WHEN THE MACHINE COMES TO THE END OF ITS WORKING LIFE. ALL PARTS SHOULD BE DISPOSED OF IN THE APPROPRIATE PLACE, EITHER BY RECYCLING OR OTHER MEANS OF DISPOSAL THAT COMPLIES WITH LOCAL REGULATIONS.

(IN UK, ENVIRONMENTAL PROTECTION ACT 1990 APPLIES)