

MonoEquip.com

Enter **Serial No.** here. \_\_\_\_\_

In the event of an enquiry please quote this serial number.

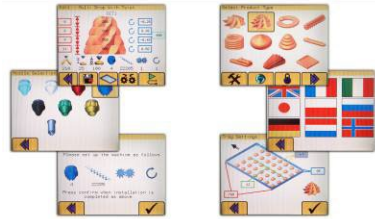

# OMEGA PLUS

## INCLUDING WIRECUT VERSION

### IMPORTANT INFORMATION and INSTALLATION INSTRUCTIONS

**The use of templates and/or accessories not produced or supplied by  
MONO Equipment will invalidate the machine's warranty**

**MONO EQUIPMENT**  
Queensway  
Swansea West Industrial Estate  
Swansea. SA5 4EB UK

Tel. +44(0)1792 561234  
email:spares@monoequip.com  
Spares Tel.+44(0)1792 564039

**COMPLETE OPERATION AND MAINTENANCE INSTRUCTIONS  
ARE AVAILABLE AT [www.monoequip.com](http://www.monoequip.com)**

**FILE 11**

# **IMPORTANT NOTICES**

---



## **WARNING**

- **This appliance must be maintained at regular intervals. The frequency of maintenance will depend upon your specific use and location. The maximum service interval should be 12 months.**
  - **Service and maintenance should only be undertaken by suitably qualified, trained, and competent engineers.**
  - **You must immediately report any damage or defect arising with the appliance.**
  - **Unsafe equipment is dangerous. Do not use the appliance. Isolate the power supply and contact MONO or your appointed service agent.**
-



# DECLARATION OF CONFORMITY

We hereby declare that this machine complies with the essential health and safety requirements of:

- The Machinery Directive 2006/42/EC
- The Low Voltage Directive 2014/35/EC
- The requirements of the Electromagnetic Compatibility Directive 2014/30/EU incorporating standards
  - o EN 55014-1:2017/A11:2020
  - o EN 55014-2:1997+A1:2001+A2:2008
- The General Safety of Machinery and food processing Standards applicable
- Materials and Articles intended to come into contact with food - Regulation (EC) No.1935/2004
- Good manufacturing practice for materials intended to come in to contact with food – Regulation (EC) No.2023/2006

<b>Signed</b>			
	<b>Craig Petherbridge – Quality Manager</b>		
<b>Date</b>			
<b>Machine FG Code.</b>		<b>Machine Serial No.</b>	

A technical construction file for this machine is retained at the following address:

**MONO EQUIPMENT**  
Queensway,  
Swansea West Industrial Park,  
Swansea  
SA5 4EB  
UK

**MONO EQUIPMENT** is a business name of **AFE GROUP Ltd**  
Registered in England No.3872673 VAT registration No.923428136

Registered Office:  
Unit 35, Bryggen Road,  
North Lynn Industrial Estate,  
Kings Lynn  
Norfolk  
PE30 2HZ  
UK

QD 001

Dated 22/07/2022

# SAFETY

---

- 1 **Never use a machine in a faulty condition** and always report any damage.
- 2 **Only trained engineers** may remove parts that need a tool to remove them.
- 3 Always ensure hands are dry before touching any electrical appliance (including cable, switch and plug).  
**NEVER move machinery by pulling on the power cords or cables.**
- 4 **Ensure that the floor area around the OMEGA is clean to avoid slipping** – especially if carrying heavy hopper and template components to and from the machine.
- 5 **All operatives must be fully trained.**  
Use of the machine can prove dangerous if:
  - the machine is operated by **untrained or unskilled staff**
  - the machine is not used for its **intended purpose**
  - the machine is **not operated correctly***All safety devices applied to the machine during manufacture and the operating instructions in the cd manual are required to operate this machine safely. The owner and the operator are responsible for operating this machine safely.*
- 6 People undergoing training on the machine must be under **direct supervision**.
- 7 **Do not operate the machine with any panels or guards removed.**
- 8 **No loose clothing or jewellery** should be worn while operating the machine.
- 9 **Switch off power** at the mains isolator when machine is not in use and **before carrying out any cleaning or maintenance.**
- 10 The bakery manager or the bakery supervisor should carry out **daily safety checks.**
- 11 Do not operate machine without a hopper, a **template and guard fitted correctly.**

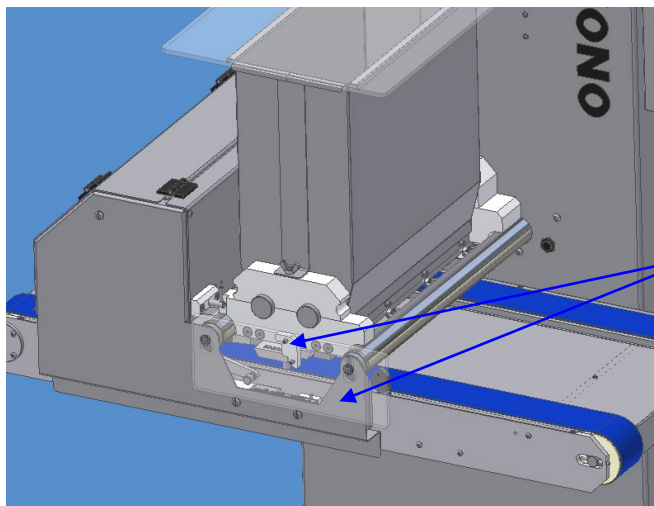

(11) HOPPER TEMPLATE AND  
GUARD FITTED

- 12 Due to the essential requirement for handling heavy components during cleaning, it is recommended that **protective footwear** be worn when carrying out such procedures.

**ALL CLEANING AND MAINTENANCE OPERATIONS MUST BE MADE WITH MACHINE DISCONNECTED FROM THE POWER SUPPLY.**

**The use of templates and/or accessories not produced or supplied by MONO Equipment will invalidate the machine's warranty**

# INSTALLATION

---

- 1 Ensure that the depositor is connected to the correct electric supply, as specified on the serial number plate on the side of the machine.
- 2 Ensure that the correct fuse rating is fitted in the electrical supply

# ISOLATION

---

**IN AN EMERGENCY, SWITCH OFF AT THE ELECTRICAL MAINS WALL ISOLATOR, OR PUSH THE EMERGENCY STOP BUTTON.**

*To release the emergency stop button, turn clockwise.*

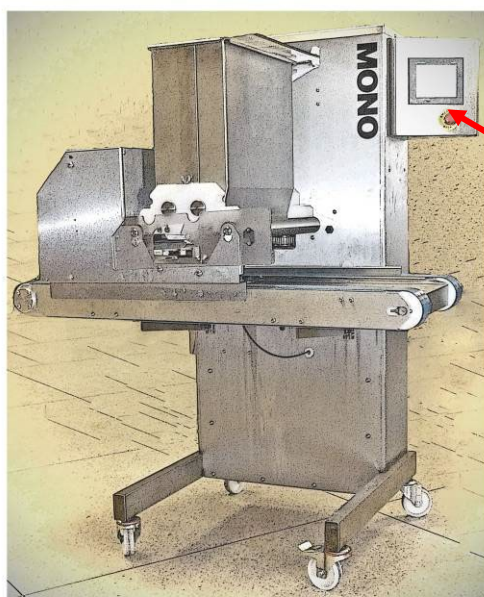

**STOP BUTTON**

# PREPARING FOR OPERATION

---

- 1 Select template and nozzles (and finger frame, if wirecut is to be used) and fit as section 9a & 9b (cd manual pages).  
Fill hopper with mix and close hopper cover.

*It is recommended that when heavy mixes are used, the inside of the hopper should be coated with vegetable oil; for lighter mixes such as meringue, dampen with water. The oil or water will help the mix to settle down the hopper walls and prevent air being sucked in.*

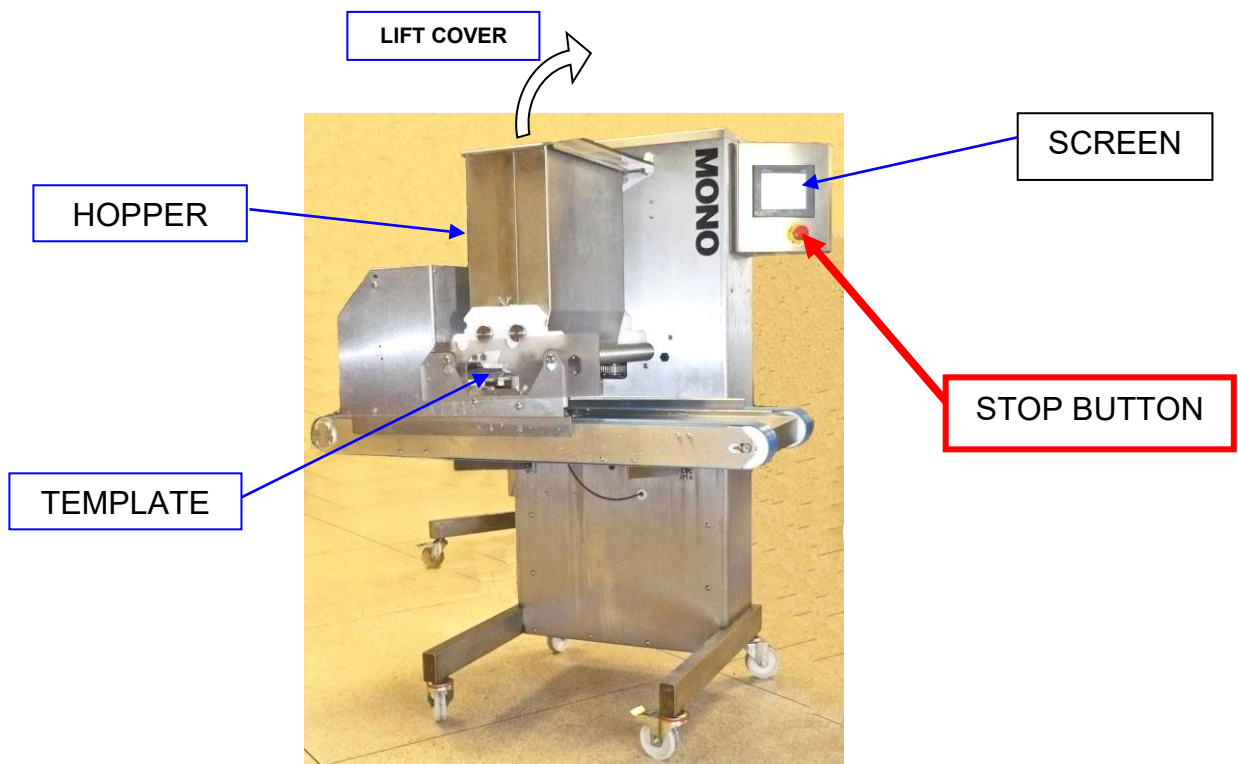

- 2 Connect power cable to electrical supply.  
*Make sure stop button is in released position (turn clockwise if required).*
- 3 Select an existing program or create a new program through the on-screen menus.  
(see “section 10 operation” in cd manual)
- 4 The machine is now ready for operation.

# **BEFORE USING STRAIGHT & OFFSET NOZZLE HOLDERS** **“O” RINGS MUST BE FITTED**

Nozzle holders provide the means of attaching standard plastic nozzles to the soft dough rotary templates and the sealing rings need to be fitted before using and may need replacing occasionally to ensure correct operation.

“O” RING PART NUMBER = A900-12-010 (SUPPLIED IN BAGS OF 20)

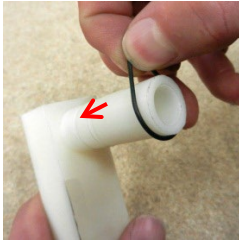

LOOP FIRST RING OVER END



SLIDE RING DOWN TO GROOVE



FIRST RING IN CORRECT POSITION

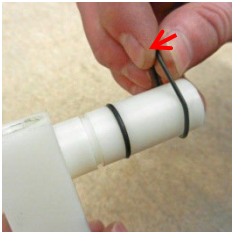

LOOP SECOND RING OVER END



SLIDE RING DOWN TO SECOND GROOVE,  
PASSING OVER FIRST RING



SECOND RING IN CORRECT POSITION

# OPERATING SCREEN

**TOUCH THE SCREEN FOR THE TYPE OF PRODUCT REQUIRED THEN → TO MOVE TO THE NEXT SCREEN**

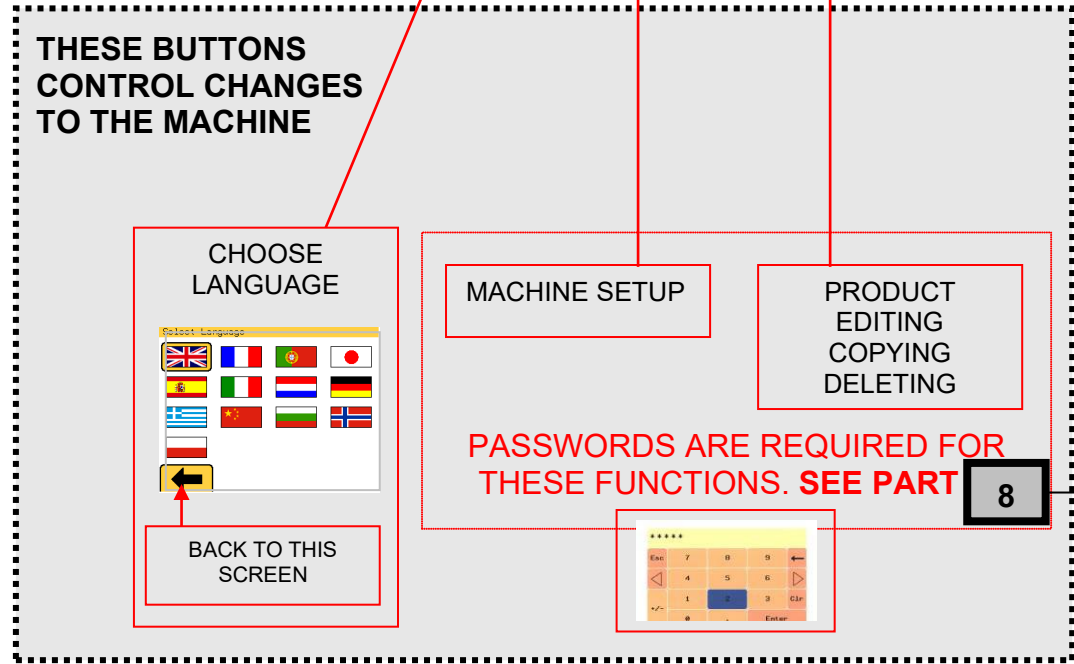
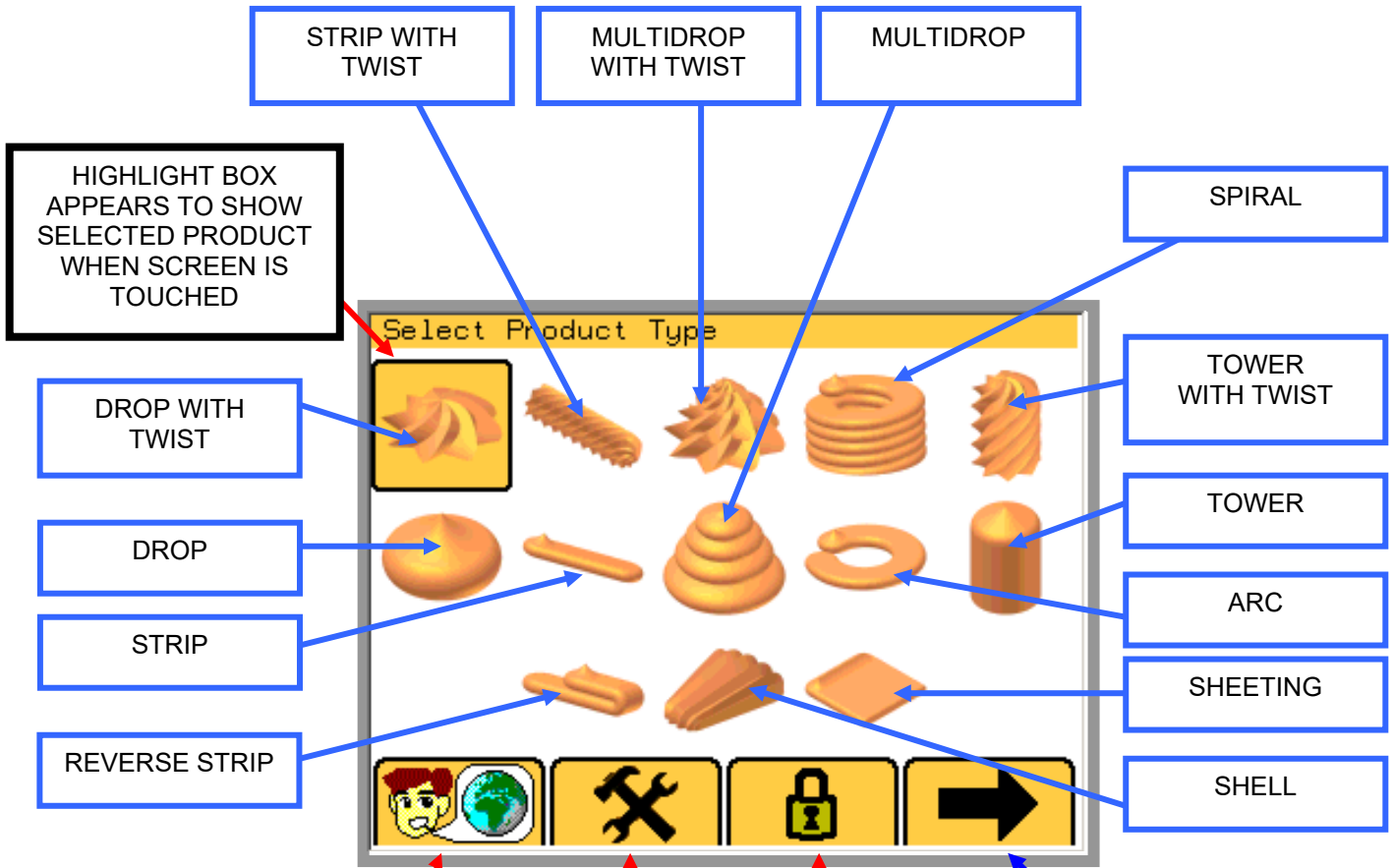

**PROGRESS TO NEXT SCREEN**

SEE THE FULL MANUAL [www.monoequip.com](http://www.monoequip.com)



# CLEANING INSTRUCTIONS

## **NOTE:**

- Cleaning must be carried out by fully trained personnel only.



- Isolate machine from mains supply before carrying out any cleaning.
- Do not steam clean or use a jet of water.

**-Do not use any form of caustic detergent or abrasive cleaners. -**

All the outer surfaces of the machine should be wiped over daily with warm soapy water.

## **HARD AND SOFT DOUGH HOPPERS** **BETWEEN PRODUCT MIX CHANGES**

*The feed hopper, pump assembly, template, nozzles etc. should be removed from the machine and dismantled for thorough cleaning between product mix changes.*

1. Open top safety guard and remove excess mixture remaining in the feed hopper.
2. Lift off front see-through safety cover.

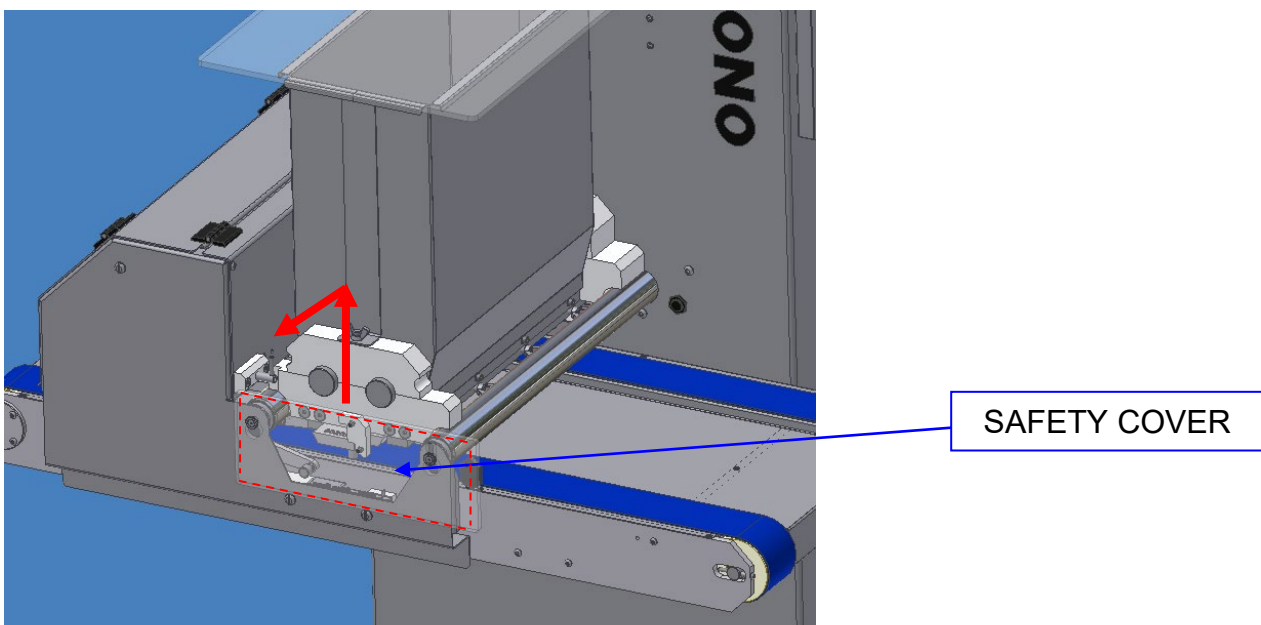

3. Slacken template clamp strip nuts or thumbscrews (depending on type of hopper)  
Remove fitted template from pump assembly by sliding out to avoid subsequent damage.

**NOTE.**

Thumbscrews only need to be released slightly to allow the template to slide away from the pump assembly. If loosened too much, the template will have to be supported.

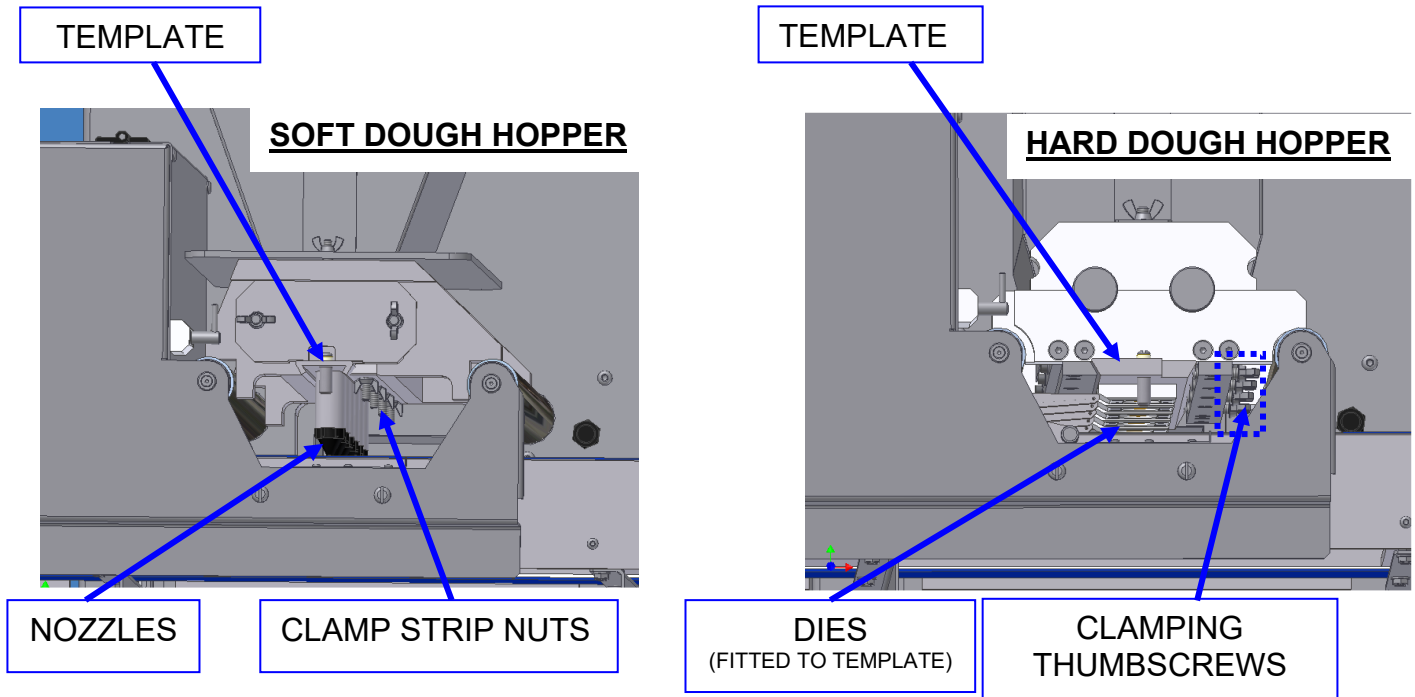

- 4 To reduce weight and bulk, separate and remove empty feed hopper from pump assembly, whilst still on the machine, by unscrewing the wing nuts.

*To gain access to the inner wing nut, slide the complete hopper away from the machine body slightly (keep on support bars) - this will also disengage the pump assembly from the drive shaft.*

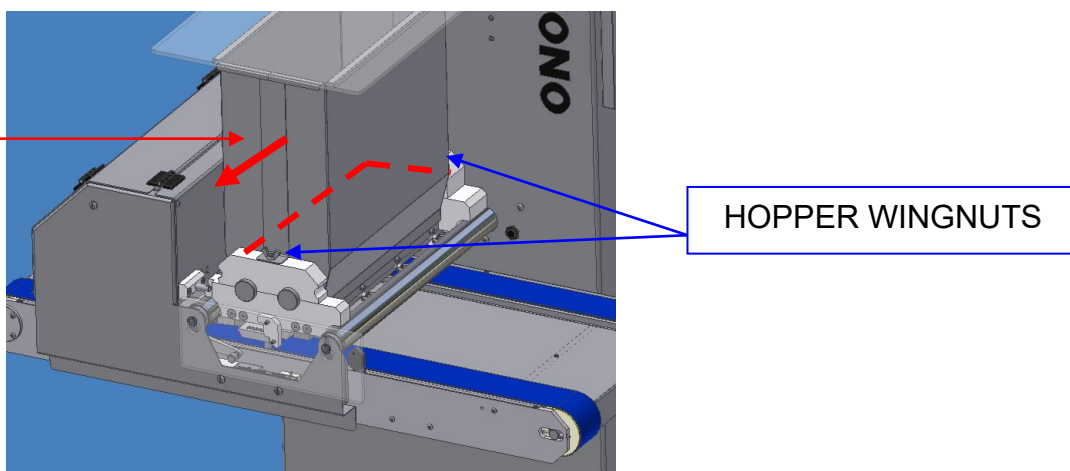

*Ensure that the nuts are placed where they will not be lost.*

# SOFT DOUGH HOPPER



## **CAUTION:**

**The feed hopper and pump assembly exceed 25kg and will need to be lifted off by two people, or dismantled into smaller components while still on the machine.**

Take care to avoid damage to the sealing surface of the feed hopper during removal, cleaning, assembly and storage.

1. After removing the feed hopper, check condition of feed hopper seal.
2. Unscrew the end cap retaining nuts from the accessible side of the pump assembly.  
*[Ensure that the nuts are placed where they will not be lost.]*

FEED HOPPER  
SEALING SURFACE

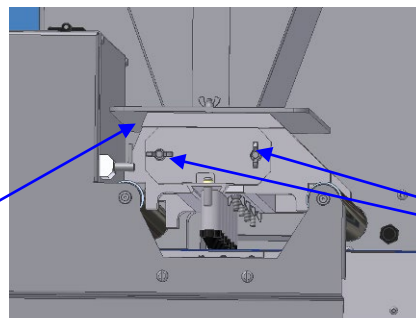

ENDCAP NUTS

3. Withdraw the end-cap with the pump gears.

*Ensure that the 'O' sealing ring on the inside of the end cap is not damaged during cleaning.*

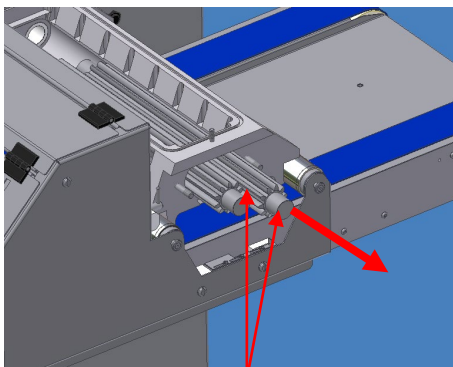

PUMP GEARS  
REMOVE WITH END CAP  
(NOT SHOWN)

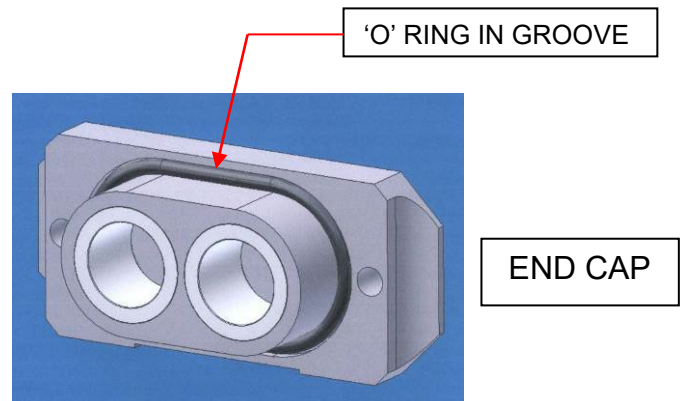

'O' RING IN GROOVE

END CAP

4. Remove remainder of pump assembly from the machine and remove remaining end-cap to fully dismantle pump assembly components for cleaning.

# HARD DOUGH HOPPER



## **CAUTION:**

**The feed hopper and pump assembly exceed 25kg and will need to be lifted off by two people, or dismantled into smaller components while still on the machine.**

To reduce weight and bulk, separate and remove empty feed hopper from pump assembly, whilst still on the machine, by unscrewing the wing nuts.

*(Ensure that the nuts are placed where they will not be lost.)*

The pump assembly will now be lighter and more easily removed.

1. Lift off both upper plastic end-caps.
2. Remove both gears from the assembly, one at a time, by lifting vertically.
3. Remove remainder of pump assembly from the machine for cleaning.

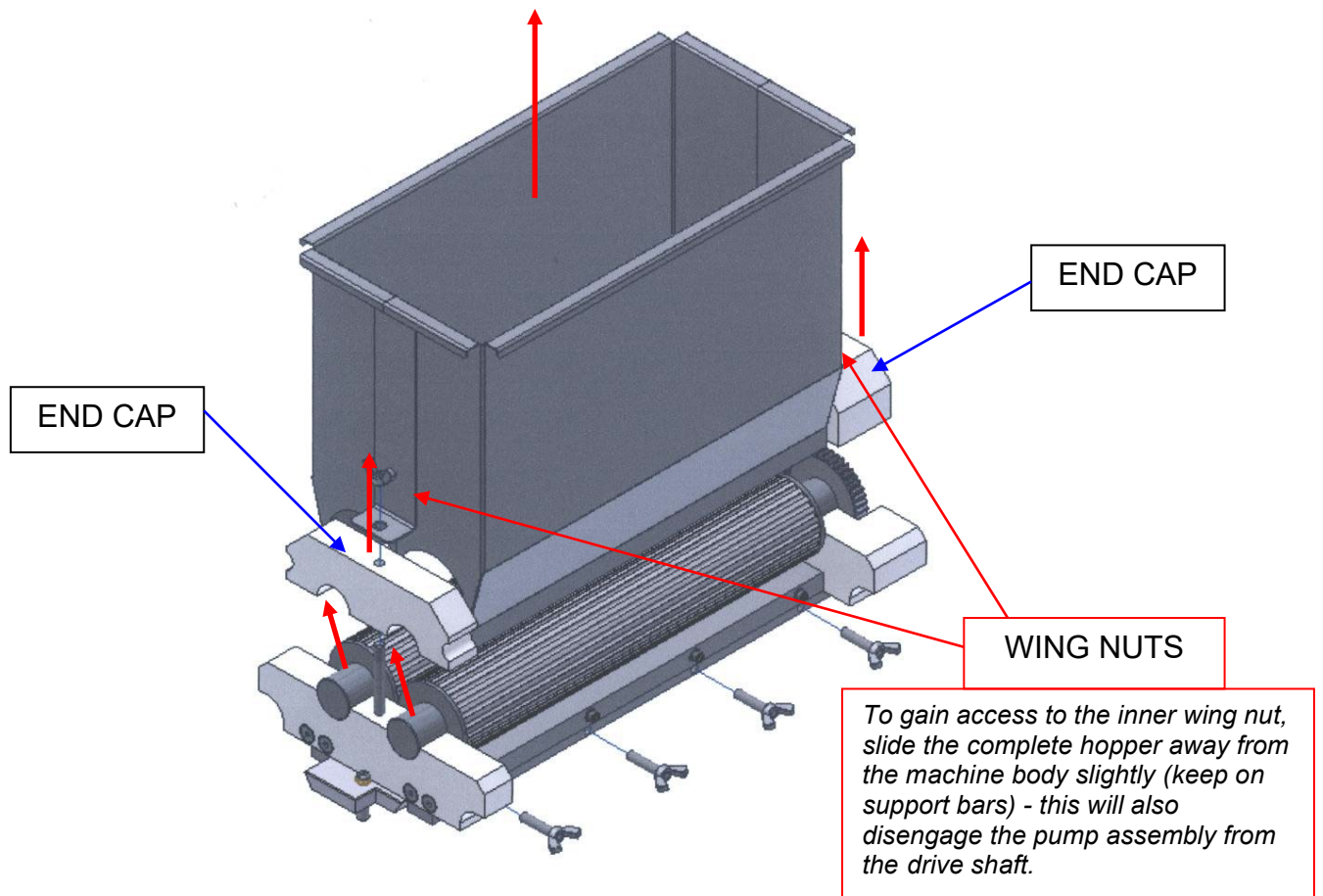

## **NOTE:**

**Use only warm soapy water to clean these parts. They should be rinsed and thoroughly dried before re-assembly.**

**The greatest care must be taken not to drop any parts.**



Do not leave any components in the hopper.

