



MonoEquip.com

Enter **Serial No.** here. \_\_\_\_\_

In the event of an enquiry please quote this serial number.



NOTE: THIS MACHINE IS FOR USE WITH SOFT DOUGH ONLY

# **Epsilon**

## **OPERATING AND MAINTENANCE MANUAL**

**The use of templates and/or accessories not produced or supplied by MONO Equipment will invalidate the machine's warranty**

# SAFETY LABELS FOR EPSILON DEPOSITOR

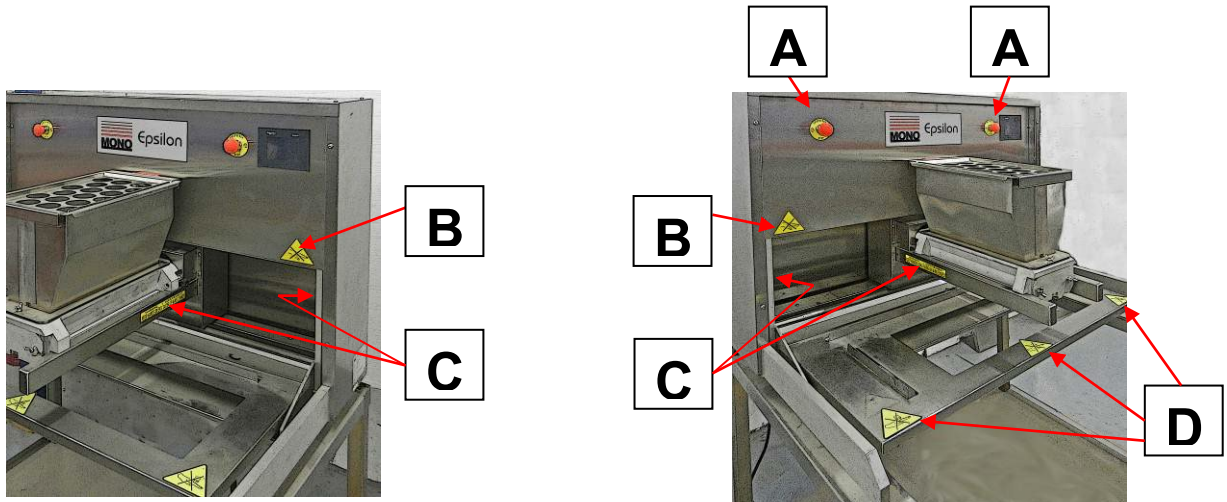

PART NUMBER  
B801-15-025



PART NUMBER  
080-00-00102



PART NUMBER 080-00-00101  
(4off EACH LABEL)



PART NUMBER  
077-11-00100

**Failure to adhere to the cleaning and maintenance instructions detailed in this booklet could affect the warranty of this machine.**



**The use of templates and/or accessories not produced or supplied by MONO Equipment will invalidate the machine's warranty**

**FOR SAFE WORKING, PAY SPECIAL ATTENTION TO ITEMS MARKED**



- 1.0 - INTRODUCTION
- 2.0 - DIMENSIONS
- 3.0 - SPECIFICATIONS
- 4.0 - SAFETY 
- 5.0 - INSTALLATION
- 6.0 - ISOLATION
- 7.0 - CLEANING INSTRUCTIONS
- 8.0 - OPERATING CONDITIONS
- 9.0 - PREPARING FOR OPERATION**
  - 9A – FITTING THE HOPPER*
  - 9B – FITTING A TEMPLATE*
- 10.0 - OPERATING INSTRUCTIONS**
  - 1** – SELECT PRODUCT TYPE
  - 2** – SELECT SAVED PRODUCT TYPE  
OR CHOOSE EMPTY SLOT TO CREATE A NEW PROGRAM
  - 3** – OPERATOR SCREEN
  - 4** – EDIT & SAVE SCREEN
    - 4A** – TRAY SETUP
  - 5** – COPY
  - 6** – DELETE
  - 7** – PASSWORDS
  - 8** – ENGINEERING SETTINGS
  - 9** – FAULT INFORMATION SCREENS
- 11.0 - MAINTENANCE
- 12.0 - SPARES AND SERVICE
- 13.0 - SPARES LIST
- 14.0 - ELECTRICAL INFORMATION

# 1.0 INTRODUCTION

**EPSILON**

- The ground-breaking **EPSILON** tabletop confectionary depositor requires a small space to operate.
- The unique travelling hopper system removes the need for a conveyor belt which means trays can be loaded and unloaded in the most ergonomically efficient way – directly from the front.
- The **EPSILON** can be transported through a normal doorway and plugged into a standard 13amp socket.
- Control is by a user-friendly tri-color touch screen (in 14 languages) and can be used to store up to 96 programs.
- Robust stainless steel construction for durability and ease of cleaning.
- A matching stainless steel table is also available to make the **EPSILON** freestanding.

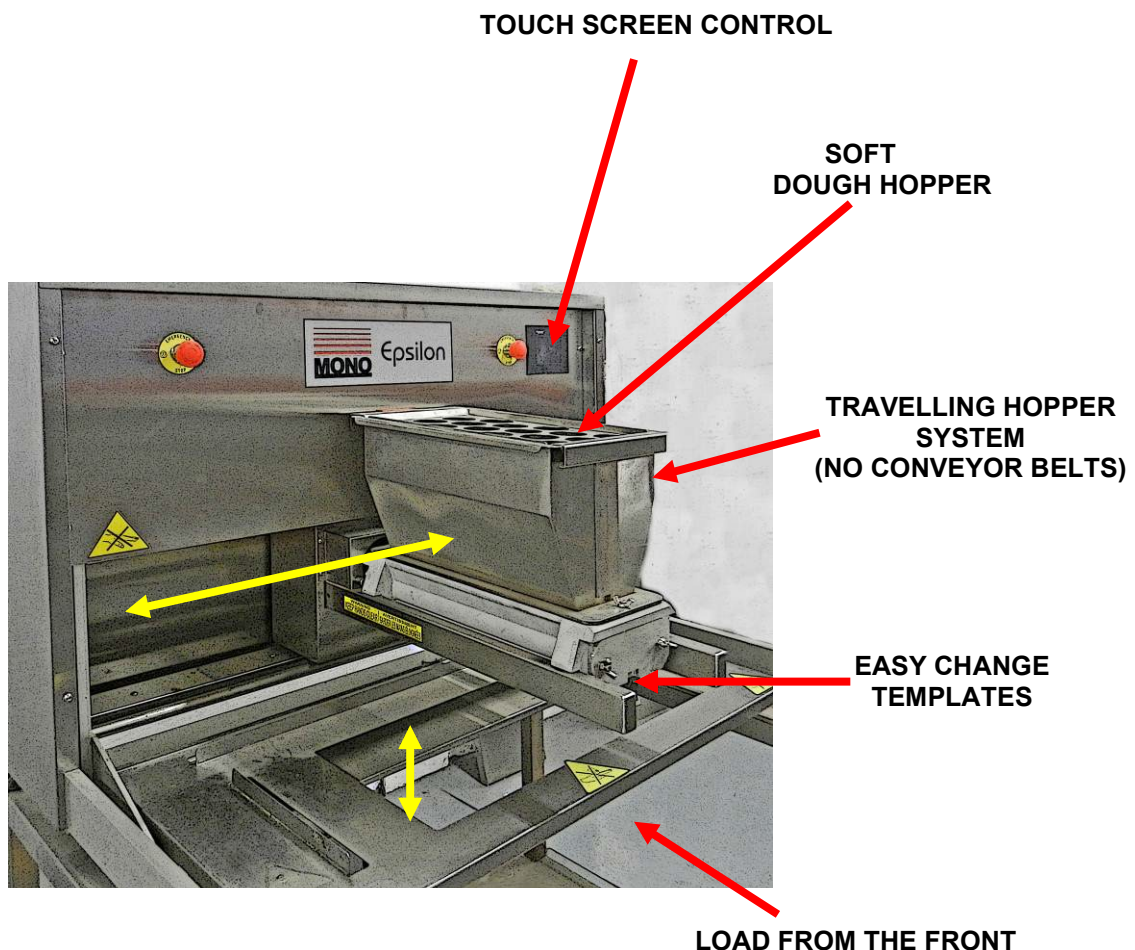

As it is our policy to improve our machines continuously, we reserve the right to change specifications without prior notice

# 2.0 DIMENSIONS

**EPSILON**

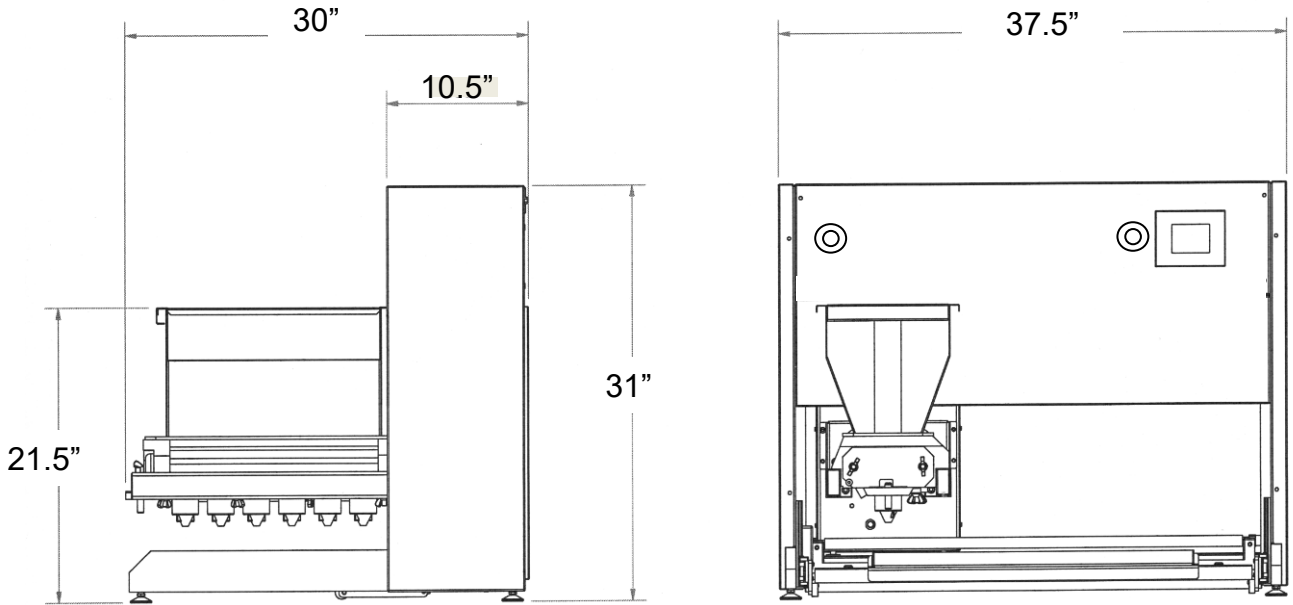

# 3.0 SPECIFICATIONS

**EPSILON**

## SOFT DOUGH

<b>MODEL</b> (Nom. hopper width (mm))	<b>400 (15.7")</b>	<b>450 (17.7")</b>
<b>Weight</b> (with hopper fitted) (Kg) :	tba	tba
<b>Standard hopper Capacity</b> (litre) :	<b>20 (35 pints)</b>	<b>22.5 (39.5 pints)</b>

**Power:** Single phase, 4.2A, 0.5kW, **120V**, 60Hz  
or 2.1A, 0.5kW, **208-240V**, 60Hz

Cycles per minute = Depends on product.  
i.e. 5 across 30g drop = 16 per minute.

Max program storage = 96

Number of languages = 14

Noise level = Less than 85dB

Electronics = All microprocessor controlled

---

### NOTE:

The minimum deposit that can be made depends on several factors - recipe, mixing method, template size, nozzle size and deposit speed.

As a guide the following is the minimum that should be attempted:

Macaroons	6g.
Meringues	3g.
Choux Paste	5g.
Viennese	4g.
Sponge Drops	4g.

However, consult **MONO Equipment** if your intended product falls outside the above general machine specification.

*As it is our policy to improve our machines continuously, we reserve the right to change specifications without prior notice.*



- 1 **Never use a machine in a faulty condition** and always report any damage.
  - 2 **Only trained engineers** may remove parts from this machine if a tool is required.
  - 3 Always ensure hands are dry before touching any electrical appliance (including cable, switch and plug). **NEVER move machinery by pulling on the power cords or cables.**
  - 4 **Ensure that the floor area around the Epsilon is clean to avoid slipping** – especially if carrying heavy hopper and template components to and from the machine.
  - 5 **All operatives must be fully trained.**
    - Use of the machine can prove dangerous if:
      - ❑ the machine is operated by **untrained or unskilled staff**
      - ❑ the machine is not used for its **intended purpose**
      - ❑ the machine is **not operated correctly**
- All safety devices applied to the machine during manufacture and the operating instructions in this manual are required to operate this machine safely. The owner and the operator are responsible for operating this machine safely.**
- 6 People undergoing training on the machine must be under **direct supervision**.
  - 7 Do not operate the machine with **any panels or guards removed**.
  - 8 **No loose clothing or jewellery** should be worn while operating the machine.
  - 9 **Switch off power** at the mains isolator when machine is not in use and before carrying out any **cleaning** or **maintenance**.



- 10 The bakery manager or the bakery supervisor should carry out **daily safety checks** on the machine.
  
- 11 Do not operate machine without the hopper **template fitted correctly**.
  
- 12 Due to the essential requirement for handling heavy components during cleaning, it is recommended that **protective footwear** be worn when carrying out such procedures.

**CAUTION:**

The feed hopper and pump assembly can exceed 55lbs and will need to be lifted off by two people, or dismantled into smaller components while still on the machine.



**ALL CLEANING AND MAINTENANCE OPERATIONS MUST BE MADE WITH MACHINE DISCONNECTED FROM THE POWER SUPPLY.**



## 5.0 INSTALLATION

EPSILON

- 1 Ensure that the depositor is connected to the correct electric supply as specified on the serial number plate on the side of the machine.
- 2 Ensure that the correct fuse rating is fitted in the electrical supply.
- 3 The support table should be level and strong enough to support the machine and loaded hopper.
- 4 This machine should be lifted by more than one person.

## 6.0 ISOLATION

**▲ IN AN EMERGENCY, SWITCH OFF AT THE MAINS WALL ISOLATOR, OR PUSH ONE OF THE EMERGENCY STOP BUTTONS.**

*To release an emergency stop button, turn clockwise.*

**STOP BUTTONS**



## 7.0 CLEANING INSTRUCTIONS

EPSILON

### NOTE:

- Cleaning must be carried out by fully trained personnel only.
- Isolate machine from mains supply before carrying out any cleaning.
- Do not steam clean or use a jet of water.

**-Do not use any form of caustic detergent or abrasive cleaners.-**

All the outer surfaces of the machine should be wiped over daily with warm soapy water.

## DOUGH HOPPERS BETWEEN PRODUCT MIX CHANGES

*The feed hopper, pump assembly, template, nozzles etc. should be removed from the machine and dismantled for thorough cleaning between product mix changes.*

1. Open top safety guard (lift front and unhook the back edge) and remove excess mixture remaining in the feed hopper.
2. Slacken template clamp strip nuts and remove fitted template from pump assembly by sliding out while supporting it to avoid damage.

### **NOTE.**

*Thumbscrews only need to be released slightly to allow the template to slide away from the pump assembly. If loosened too much, the template will have to be supported.*

### DOUGH HOPPER

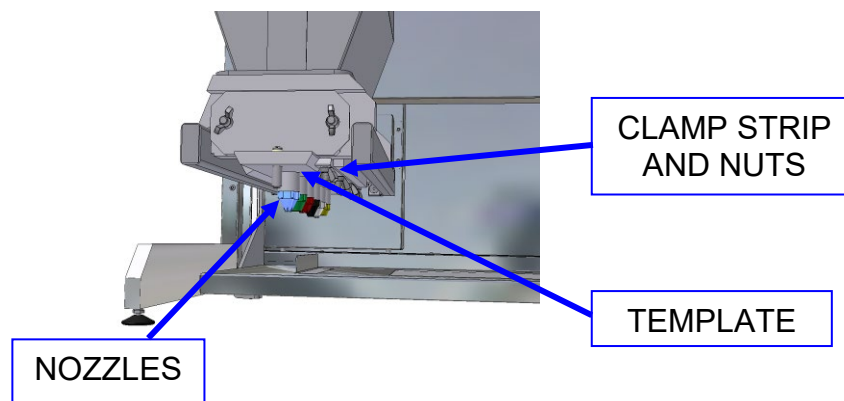

- 3 To reduce weight and bulk, separate and remove the empty feed hopper from the pump assembly, by unscrewing the wing nuts, whilst still on the machine,.

*To gain access to the inner wing nut, slide the complete hopper away from the machine body slightly (keep on support bars) - this will also disengage the pump assembly from the drive shaft.*

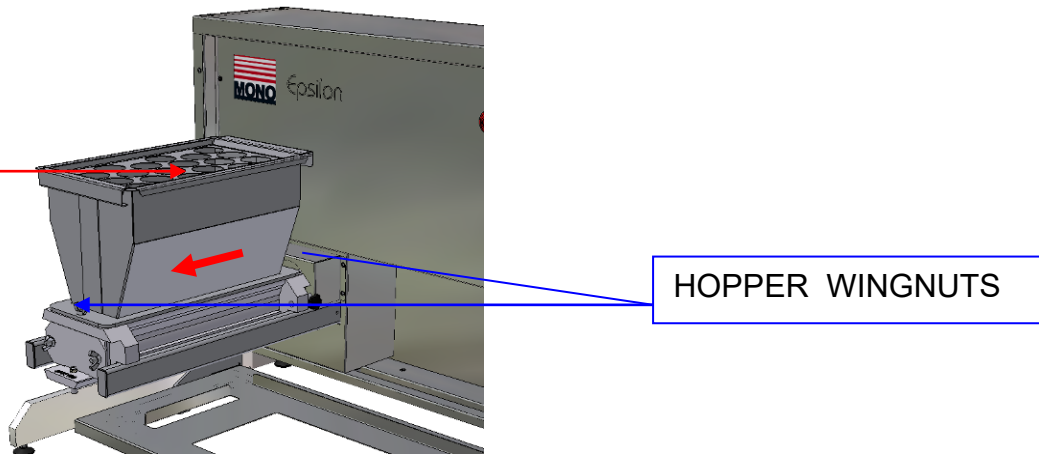

*Ensure that the wing nuts are placed where they will not be lost.*

# DOUGH HOPPER

EPSILON

NOTE: THIS MACHINE IS FOR USE WITH SOFT DOUGH ONLY

**CAUTION:**  
The feed hopper and pump assembly can exceed 55lbs and will need to be lifted off by two people, or dismantled into smaller components while still on the machine.

Take care to avoid damage to the sealing surface of the feed hopper during removal, cleaning, assembly and storage.

1. After removing the feed hopper, check condition of feed hopper seal.
2. Unscrew the end cap retaining nuts from the accessible side of the pump assembly.  
*Ensure that the nuts are placed where they will not be lost.*

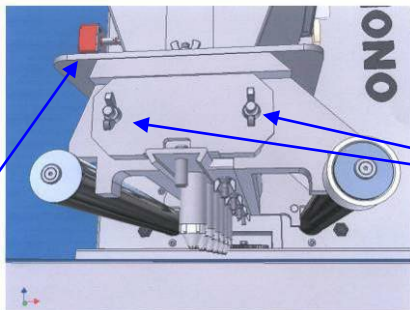

FEED HOPPER SEALING SURFACE

ENDCAP NUTS

3. Withdraw the end-cap with the pump gears.

*Ensure that the 'O' sealing ring on the inside of the end-cap is not damaged during cleaning.*

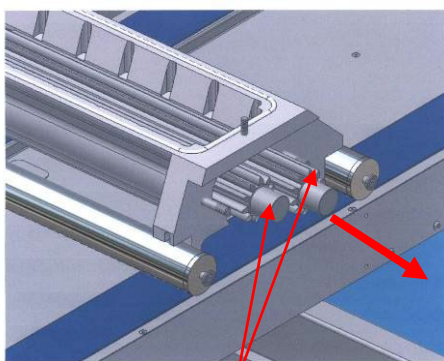

PUMP GEARS  
REMOVE WITH END CAP  
(NOT SHOWN)

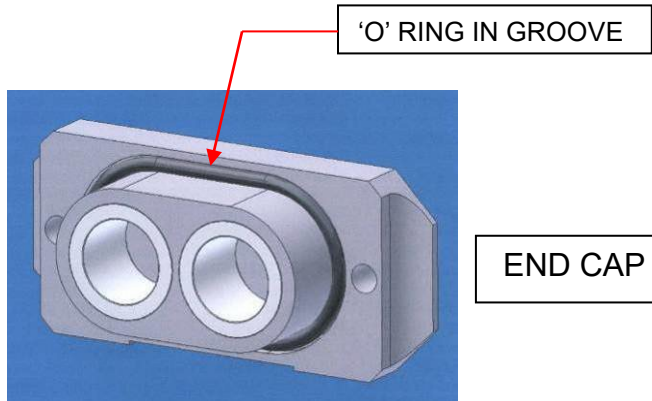

'O' RING IN GROOVE

END CAP

4. To fully dismantle pump assembly components for cleaning, remove remainder of pump assembly from the machine and remove remaining end-cap.

PICTORIAL VIEWS SHOWN COULD BE DIFFERENT TO THE MACHINE BEING WORKED ON BUT THE INSTRUCTIONS ARE THE SAME FOR ALL MODELS.

To remove the table for cleaning:

1. Push the table down to its lowest level.
2. Lift the front edge and lift the table towards you.  
The table will release from the back pins and can be placed in a washer for cleaning.

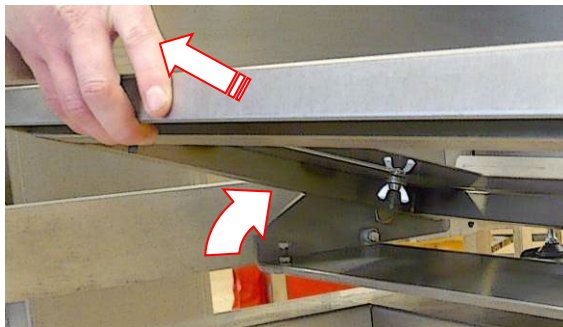

To replace the table after cleaning:

1. Hold table with the front edge raised and engage the slots over the pin on both sides.
2. Lower the table front edge.

When in the correct position the table will not slide forward.

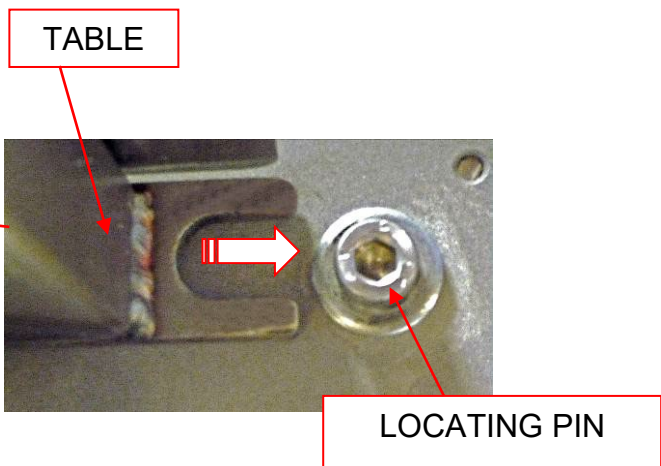
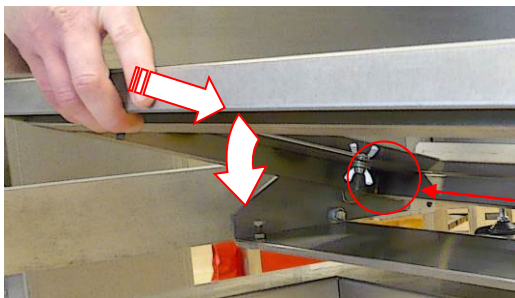

To obtain the best product results and consistent operation,

- ✓ Make sure the depositor is used on a **level surface**.  
(Adjust feet if required)
- ✓ Ensure **flat trays** are used.
- ✓ Ensure **undamaged** nozzles and templates are used.
- ✓ Keep the machine **clean**.
- ✓ Do not leave any components in the hopper.



NOTE: THIS MACHINE IS FOR USE WITH SOFT DOUGH ONLY

**EPSILON**

## 9.0 PREPARING FOR OPERATION

The use of templates and/or accessories not produced or supplied by MONO Equipment will invalidate the machine's warranty

- 1 Select template and nozzles required and fit as section 9a & 9b following.  
Fill hopper with mix and close hopper guard.

*It is recommended that when heavy mixes are used, the inside of the hopper should be coated with vegetable oil and for lighter mixes such as meringue, dampen with water. The oil or water will help the mix to settle down the hopper walls and prevent air being sucked in.*

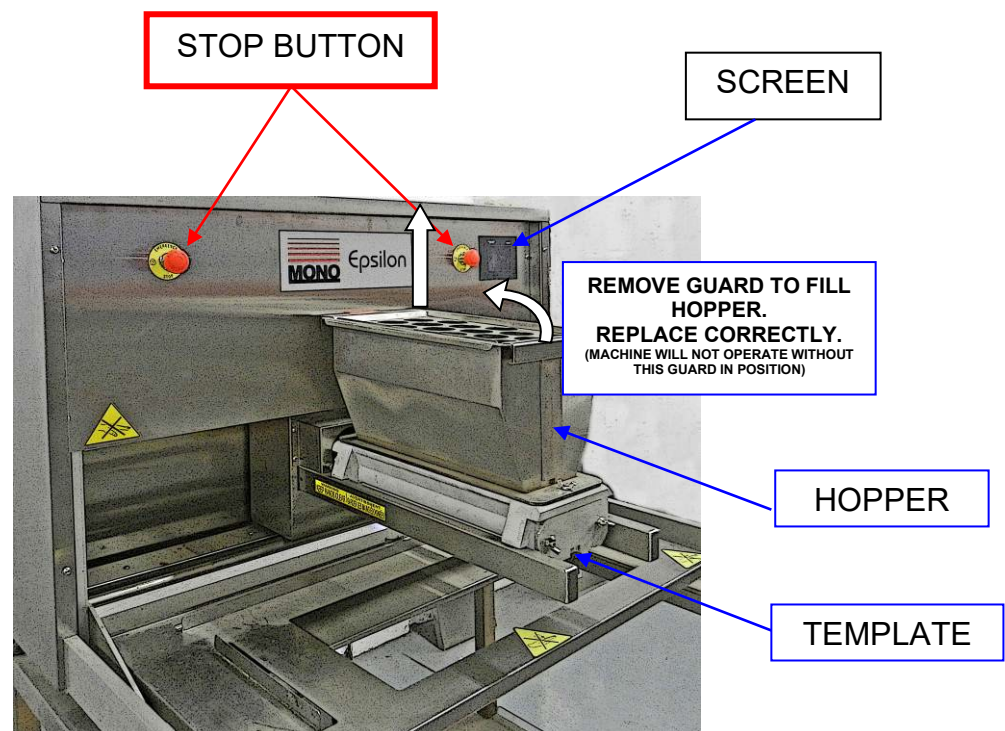

- 2 Connect power cable to the correct electrical supply.  
*Make sure stop button is in released position (turn clockwise if required).*
- 3 Select an existing program or create a new program through the on-screen menus.  
(see section 10 operation)
- 4 The machine is now ready for operation.



## TABLE ADJUSTMENTS

It is important that the table is parallel with the hopper.  
*(If this is not correct the nozzles will not be the same distance from the trays and the deposits will differ across the tray).*

Measure the distance at “A” and “B” below and check that they are the same.  
 This should be checked with the hopper bars positioned at both the full left position and the full right position.

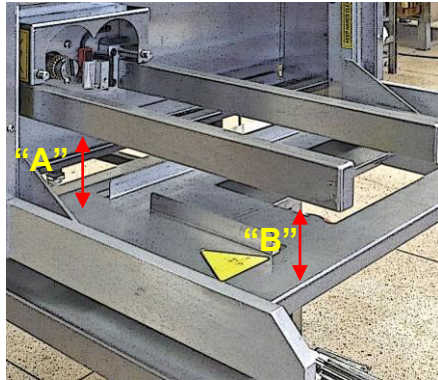

If not the same, an adjustment can be made by raising or lowering the adjusters under the table. There is one each side to allow the table to be adjusted evenly.

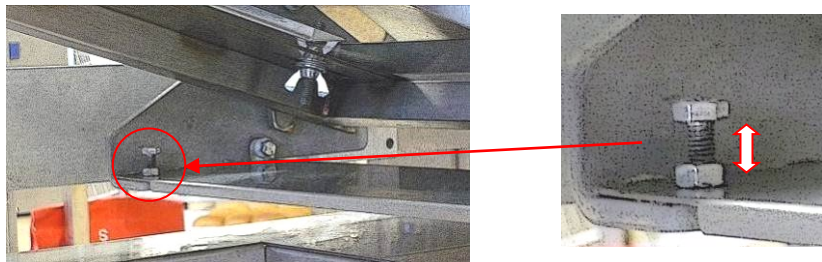

Lift the front edge of the table and, with a suitable spanner, release the locking nut. screw the adjuster bolt up or down and then lock it in position with the locking nut.

## TRAY GUIDE ADJUSTMENT

This allows different width trays to be accommodated.  
 To adjust the position of the back guide, remove the table and turn it over. Loosen the thumb nuts and slide the sheet across to the desired position. Tighten the nuts and replace the table.

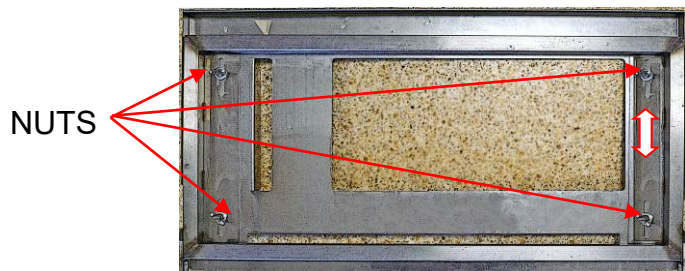
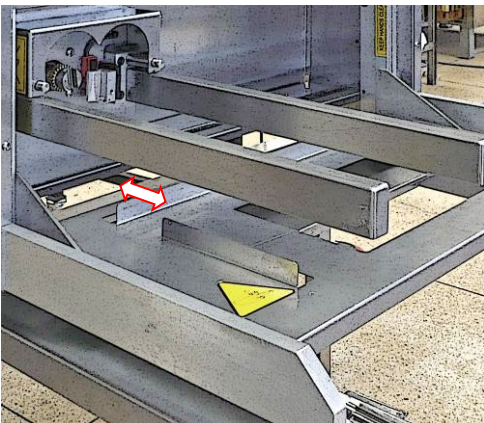

□ **9a FITTING THE HOPPER**

**CAUTION SHOULD BE TAKEN WHEN FITTING HOPPER AND PUMP ASSEMBLY AS WEIGHT EXCEEDS 55lbs ON SOME MODELS**  
**It will need to be lifted off by two people, or dismantled into smaller components while still on the machine.**  
MAKE SURE FLOOR AREA AROUND MACHINE IS CLEAN

To reduce weight and bulk fit the complete hopper assembly in two stages - first the pump assembly onto the support bars, then the feed hopper body onto the pump assembly.

- 1 By hand, align pump assembly drive gear roller with drive shaft on machine.
- 2 Fit hopper to pump assembly and secure with wing nuts.
- 3 Slide hopper on support bars until fully up against machine.
- 4 Screw hopper locking knob hand tight.

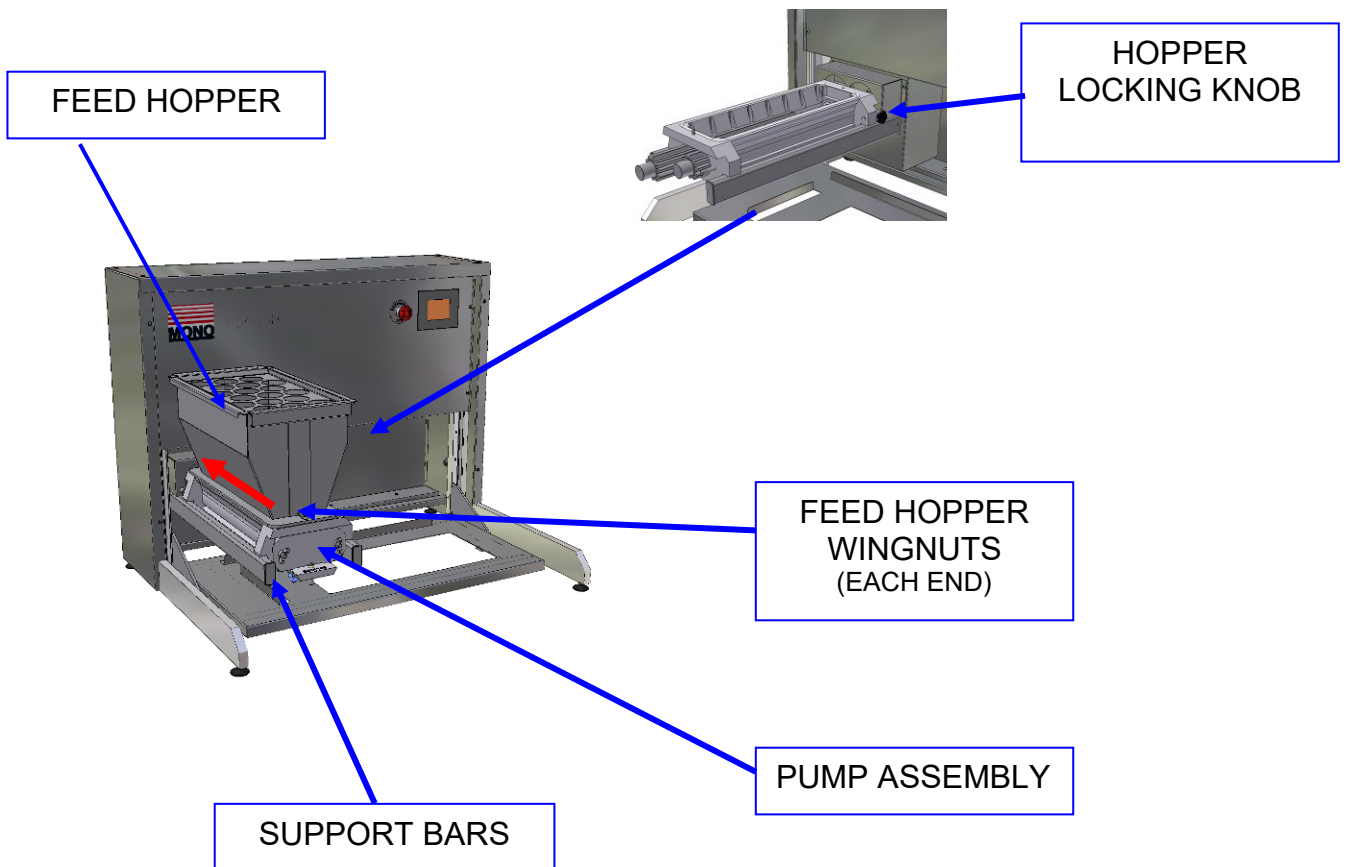

**DO NOT OPERATE MACHINE WITHOUT TEMPLATE FITTED**

## 9b FITTING A TEMPLATE

EPSILON

- 1 Select template and nozzles required.  
(Nozzles are not required for sheeting, staggered or stub templates)
- 2 Attach nozzles to template body:

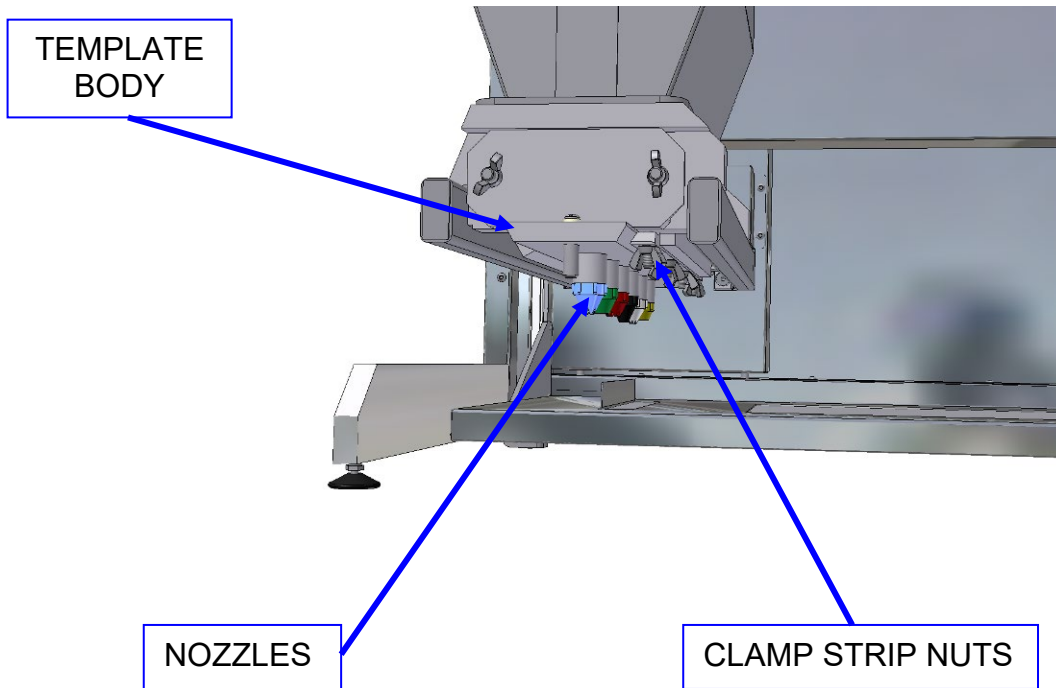

- 3 Slide template into matching recess at base of pump assembly until the stop is in position.
- 4 Tighten nuts on clamp strip (on underside of pump assembly) to secure template.

**NOTE.** *If the nuts are not securely tightened, leakage of mix will occur, affecting deposit weights.*

**DO NOT OPERATE MACHINE WITHOUT TEMPLATE FITTED**

# 10.0 'Epsilon' OPERATION

EPSILON



ALL OPERATIONS ARE ACTIVATED BY TOUCHING AREAS ON THE SCREEN WITH A FINGER.  
DO NOT USE EXCESSIVE FORCE OR HARD OBJECTS AS THIS WILL INVALIDATE MACHINE WARRANTY.

# OPERATING KEY

## FOR FOLLOWING INSTRUCTIONS

**BLUE = OPERATION** FOLLOW BLUE ARROWS AND BOXES TO OPERATE THE DEPOSITOR WITH ALREADY SAVED PROGRAMS

**RED = CHANGE SETTINGS** FOLLOW RED ARROWS AND BOXES TO CHANGE SETTINGS AND CREATE NEW PROGRAMS

 **= KEYBOARD ENTRY REQUIRED** WHEN KEYBOARD APPEARS, A CODE MUST BE ENTERED BY TOUCHING THE NUMBERS IN THE CORRECT ORDER

IF A GREY BOX IS SHOWN IN THE BUTTON DESCRIPTION  
 e.g. 7 GO TO THE CORRESPONDING PAGE FURTHER ON IN THE INSTRUCTIONS.

(MARKED IN TOP RIGHT HAND CORNER OF EACH PAGE)

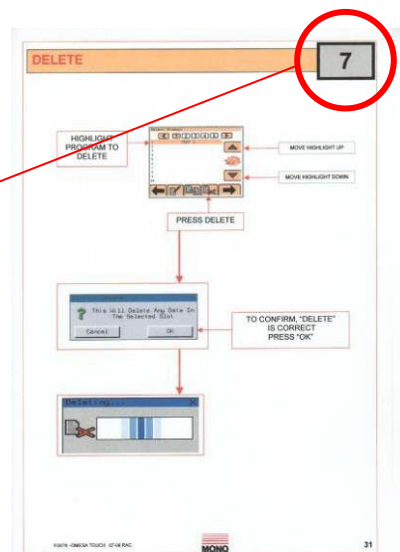
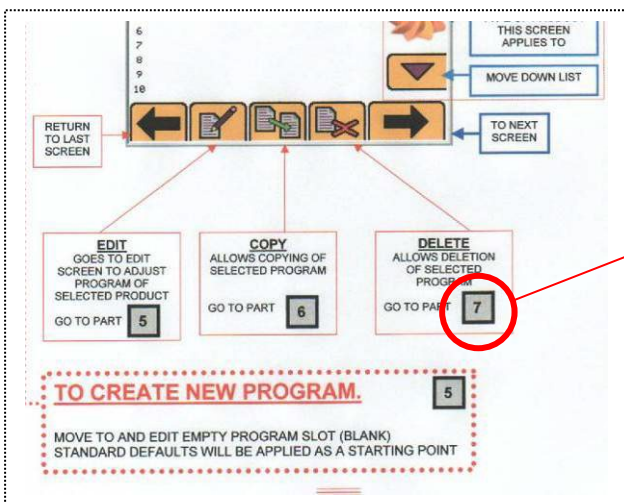

# SELECT PRODUCT TYPE

SELECT PRODUCT TO DEPOSIT OR TO CREATE NEW PROGRAM

PART  
**1**

ALL OPERATIONS ARE ACTIVATED BY TOUCHING AREAS ON THE SCREEN WITH A FINGER.  
DO NOT USE EXCESSIVE FORCE OR HARD OBJECTS AS THIS WILL INVALIDATE MACHINE WARRANTY.

**TOUCH THE SCREEN FOR THE TYPE OF PRODUCT REQUIRED  
THEN TOUCH  TO MOVE TO THE NEXT SCREEN**

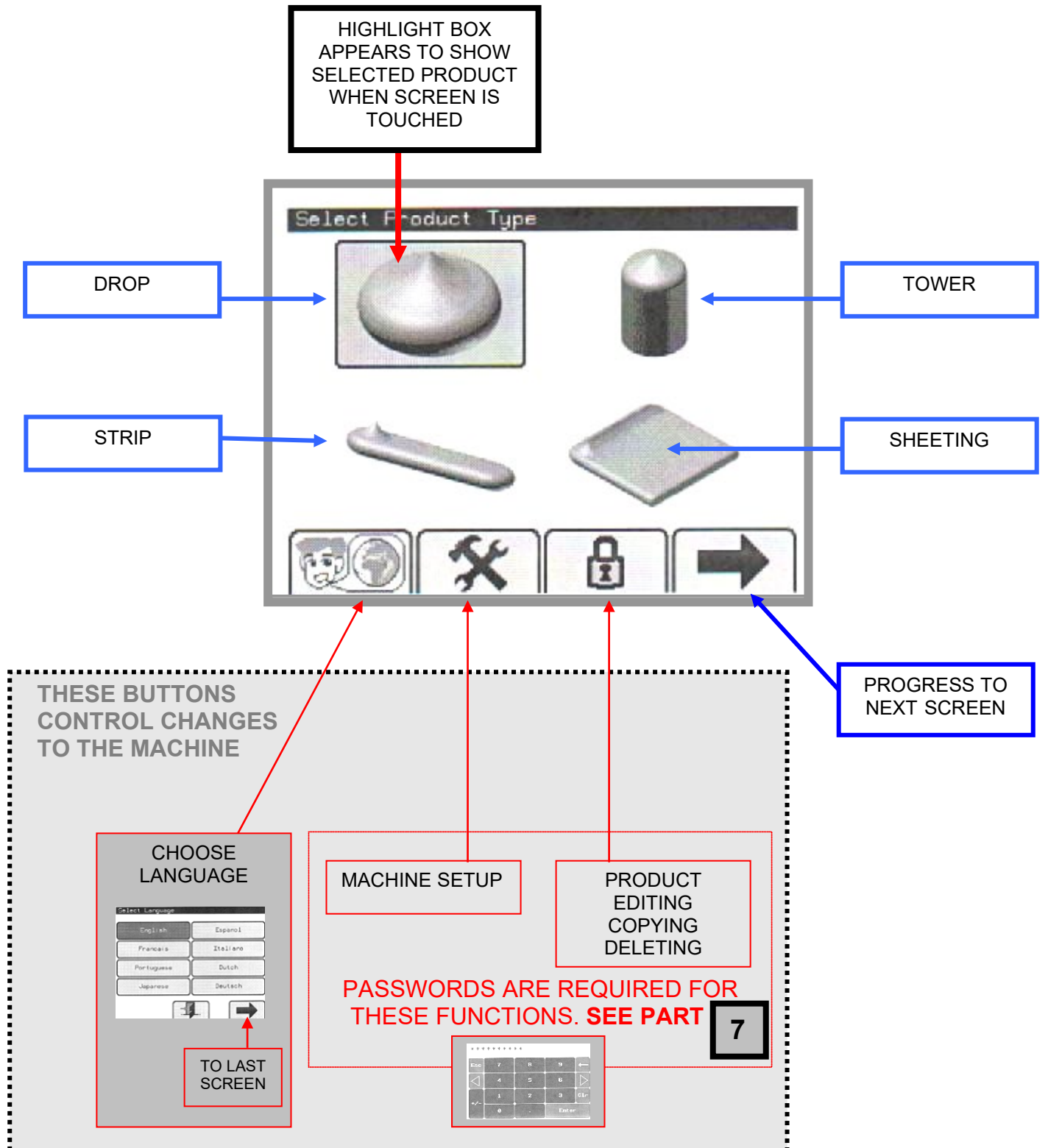

# SELECT SAVED PRODUCT TYPE

OR CHOOSE EMPTY SLOT TO CREATE A NEW PROGRAM

PART  
**2**

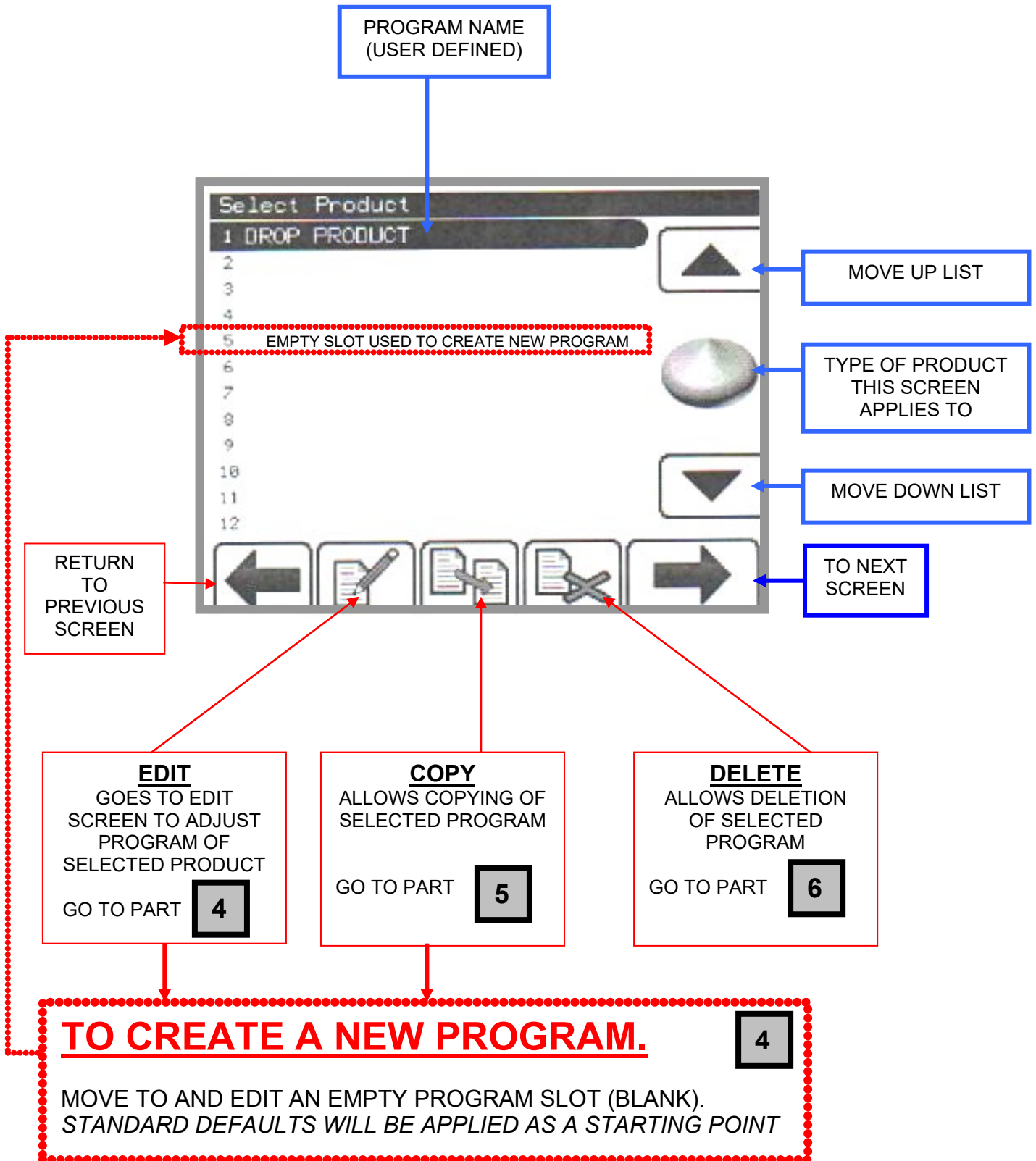

THIS SCREEN CONTROLS THE ACTIONS REQUIRED BY THE OPERATOR.

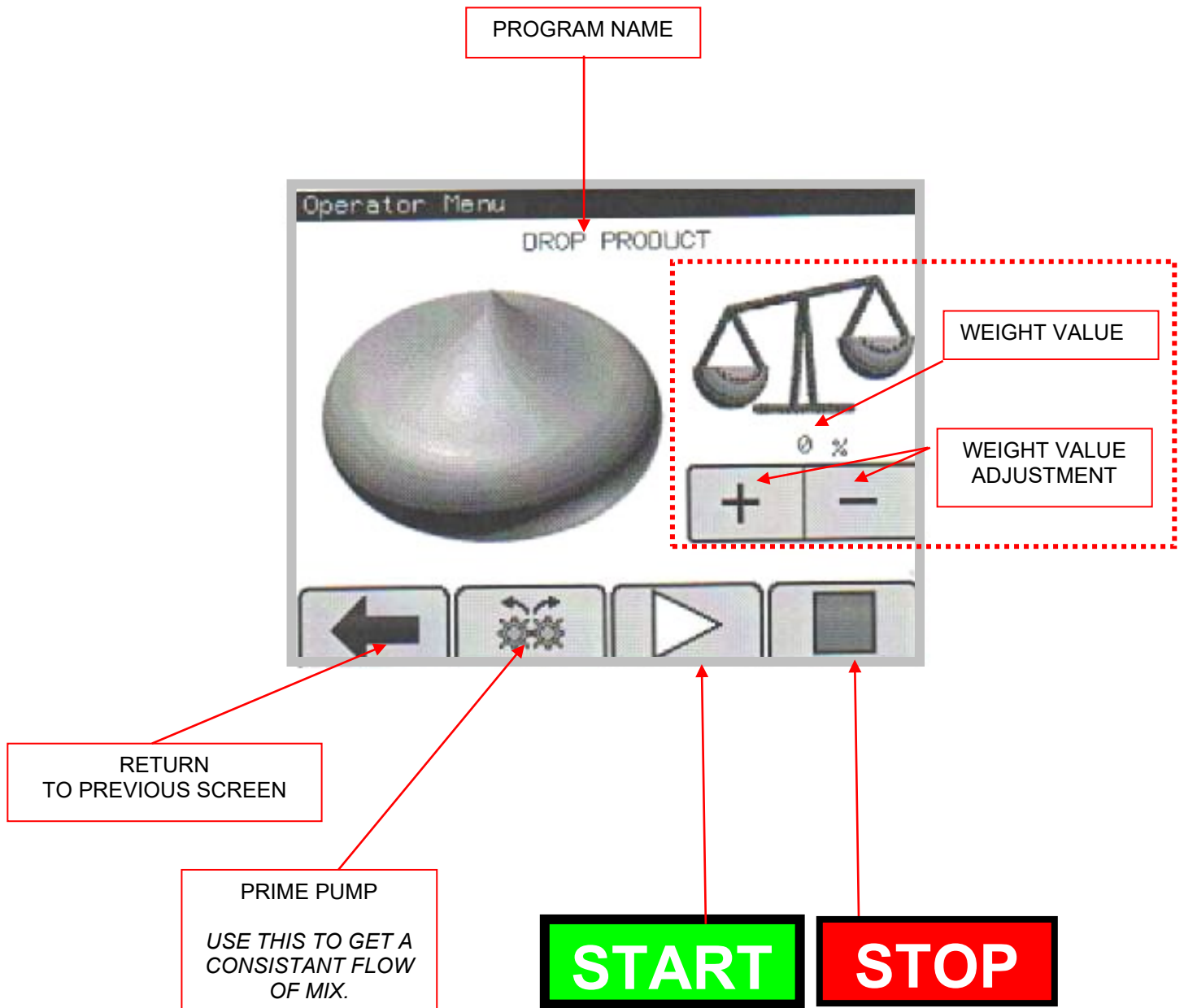



# EDIT AND SAVE SCREEN

**EXAMPLE:  
DROP**



**PROGRAM NAME**  
MUST BE ENTERED TO  
ALLOW PROGRAM TO SAVE

**PRODUCT QUANTITY**  
THIS IS A SETTING NUMBER AND  
DOES NOT INDICATE A MEASURE OF  
ACTUAL VOLUME

**NOZZLE HEIGHT**  
ABOVE TRAY  
SURFACE

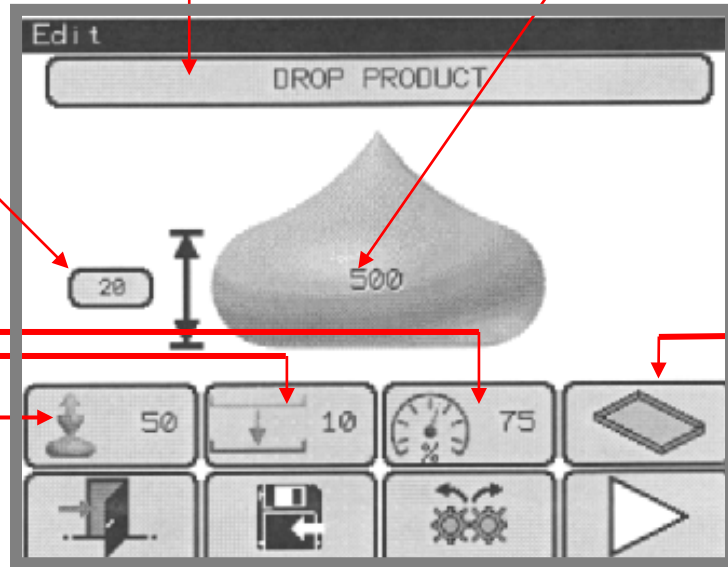

ENTER  
TRAY  
SETUP  
SCREEN

GO TO PART  
**4A**

**EXIT THIS SCREEN**

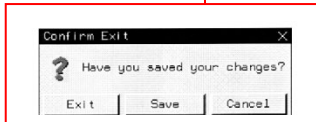

**START  
MANUAL MODE**

**PRIME PUMP**

**SAVE EDITS**

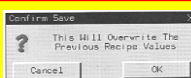

**SUCK BACK  
QUANTITY**

**TABLE  
JOG DISTANCE (mm)**

**OVERALL  
MACHINE SPEED  
(% OF MAXIMUM)**

**SETTING ERROR INDICATOR**

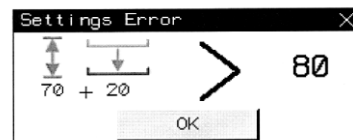

NOZZLE HEIGHT ABOVE TRAY SURFACE  
AND THE JOG DISTANCE IS OVER 80mm THIS  
ERROR SCREEN WILL SHOW.  
RESET TO LOWER FIGURES TO CONTINUE.

**EXAMPLE:  
TOWER**



DEPOSIT QUANTITY FOR EACH LAYER

NOZZLE HEIGHT (mm) FOR EACH LAYER

NOZZLE HEIGHT (mm) FROM TRAY SURFACE

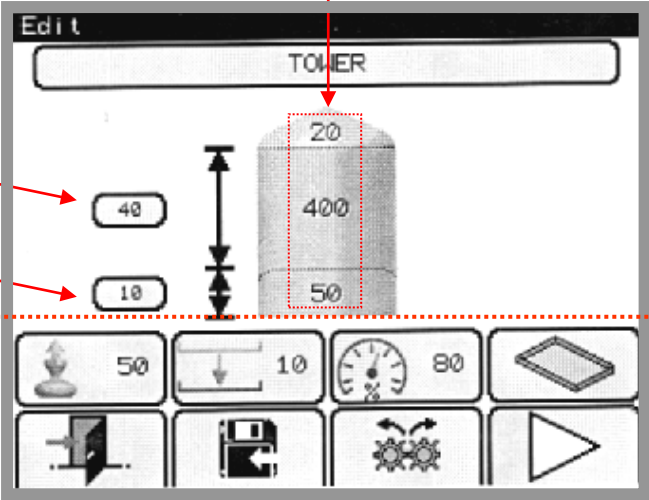

OTHER SETTING BUTTONS ARE THE SAME AS THE PREVIOUS PAGE

**EXAMPLE:  
STRIP**

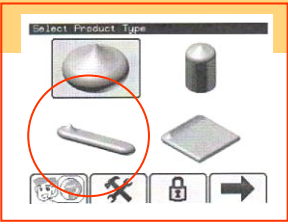

DEPOSIT QUANTITY FOR BEGINNING OF PRODUCT

DEPOSIT QUANTITY FOR LENGTH

NOZZLE HEIGHT ABOVE TRAY SURFACE

DEPOSIT QUANTITY FOR END OF PRODUCT (-VE VALUES POSSIBLE)

LENGTH (mm) OF DEPOSIT

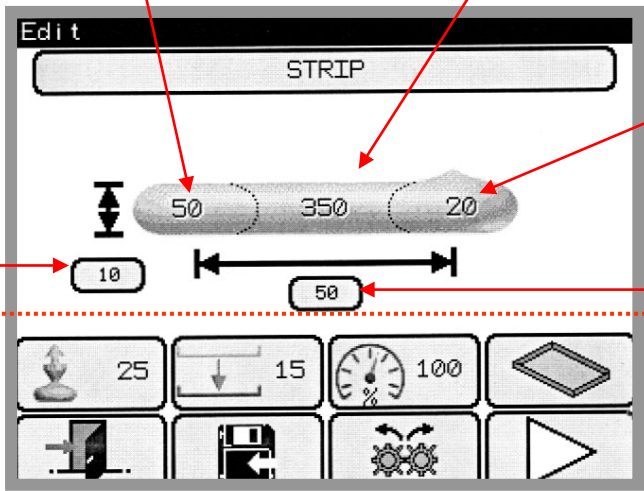

OTHER SETTING BUTTONS ARE THE SAME AS THE PREVIOUS PAGE

## EXAMPLE: SHEETING



DEPOSIT QUANTITY  
FOR BEGINNING OF  
PRODUCT

DEPOSIT QUANTITY  
FOR LENGTH

DEPOSIT QUANTITY  
FOR END OF  
PRODUCT  
(-VE VALUES POSSIBLE)

NOZZLE HEIGHT  
ABOVE TRAY  
SURFACE

LENGTH (mm) OF  
DEPOSIT

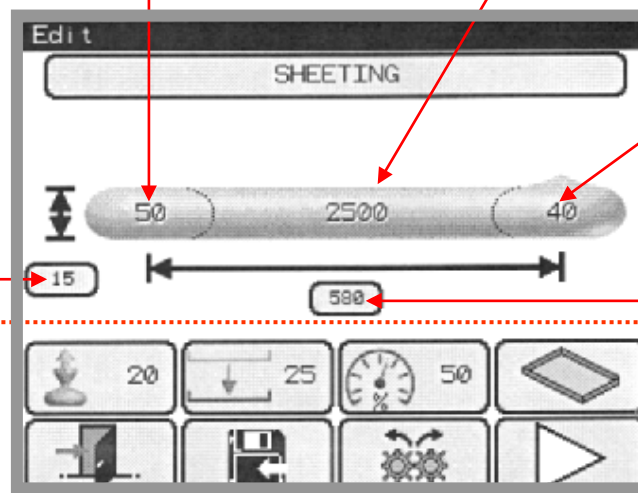

OTHER SETTING BUTTONS ARE THE  
SAME AS THE PREVIOUS PAGE

# TRAY SETUP

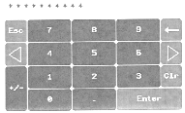

PRESS WINDOWS AND ENTER VALUES VIA KEYPAD

**DISTANCE (mm) BETWEEN ROWS**  
(WHEN USING MANUAL OVER-RIDE)

**DISTANCE (mm) TO 1<sup>ST</sup> ROW ON TRAY**  
(WHEN USING MANUAL OVER-RIDE)

**MANUAL OVER-RIDE FOR ROW SPACING**  
ON/OFF

**NUMBER OF ROWS PER TRAY**

**TRAY LENGTH (mm)**

**TO PREVIOUS SCREEN**

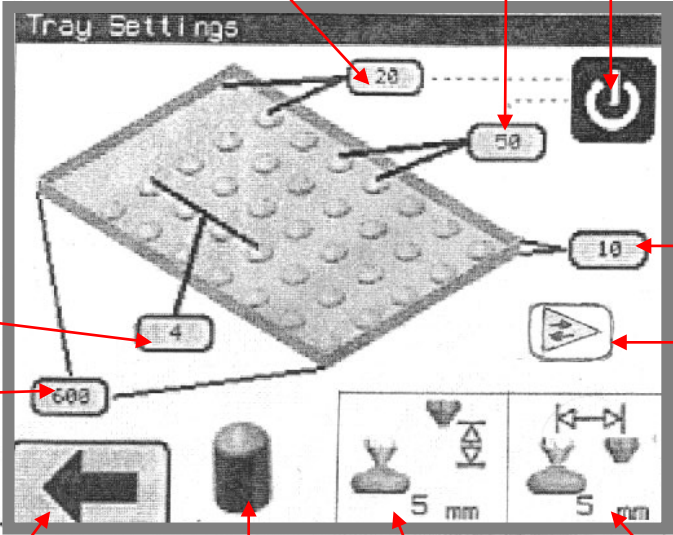

**TRAY EDGE HEIGHT (mm)**

**DEPOSIT DIRECTION**  
TOGGLES BETWEEN TWO WAY (DEFAULT) OR ONE WAY

**PRODUCT TYPE**

**VERTICAL DISTANCE MOVED BY HOPPER AFTER DEPOSIT**

**HORIZONTAL DISTANCE MOVED BY HOPPER AFTER DEPOSIT**

**WIPE BACK**

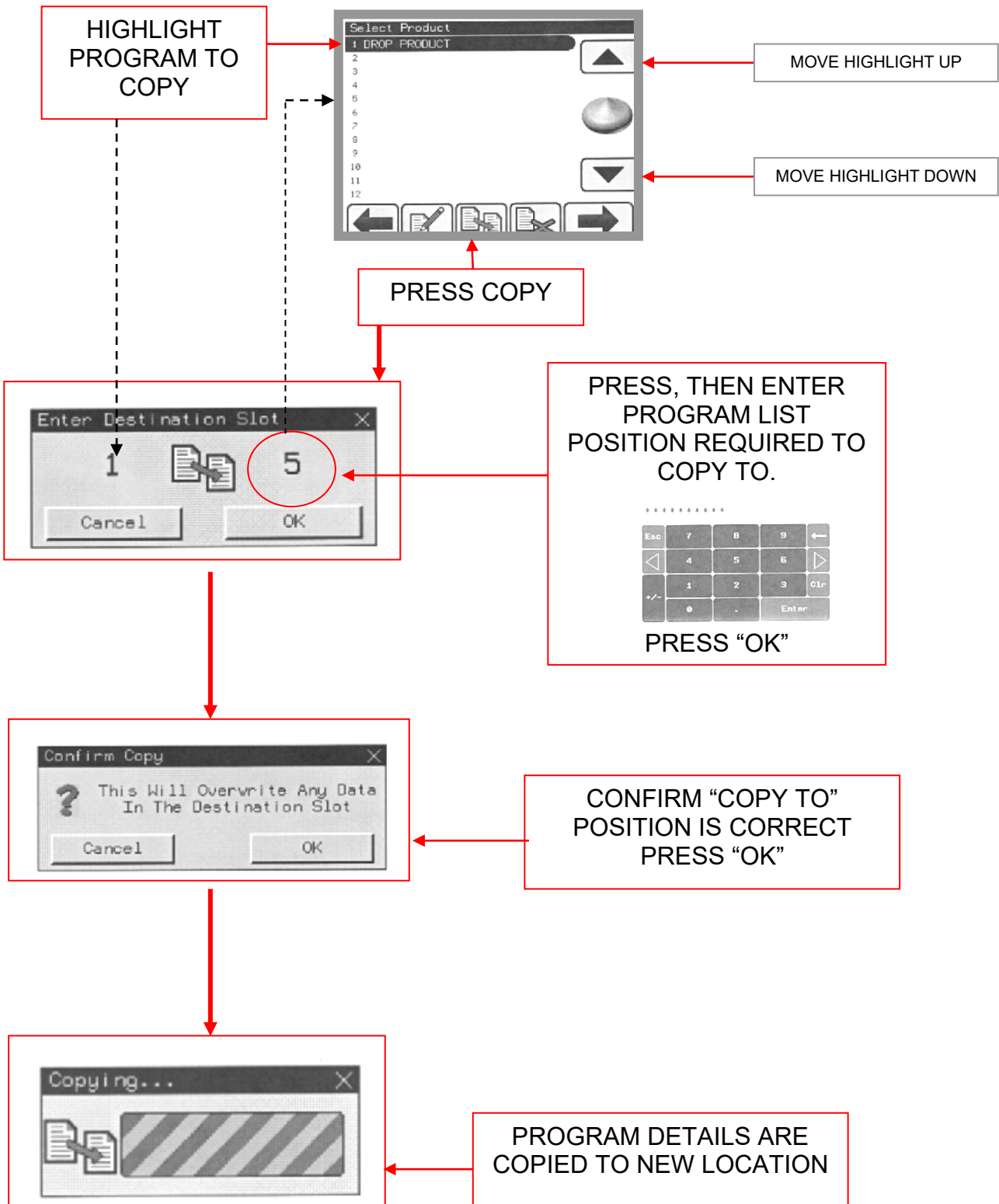

## CAUTION

DO NOT ATTEMPT TO DELETE, UNLESS YOU ARE FULLY AWARE OF THE RESULTS

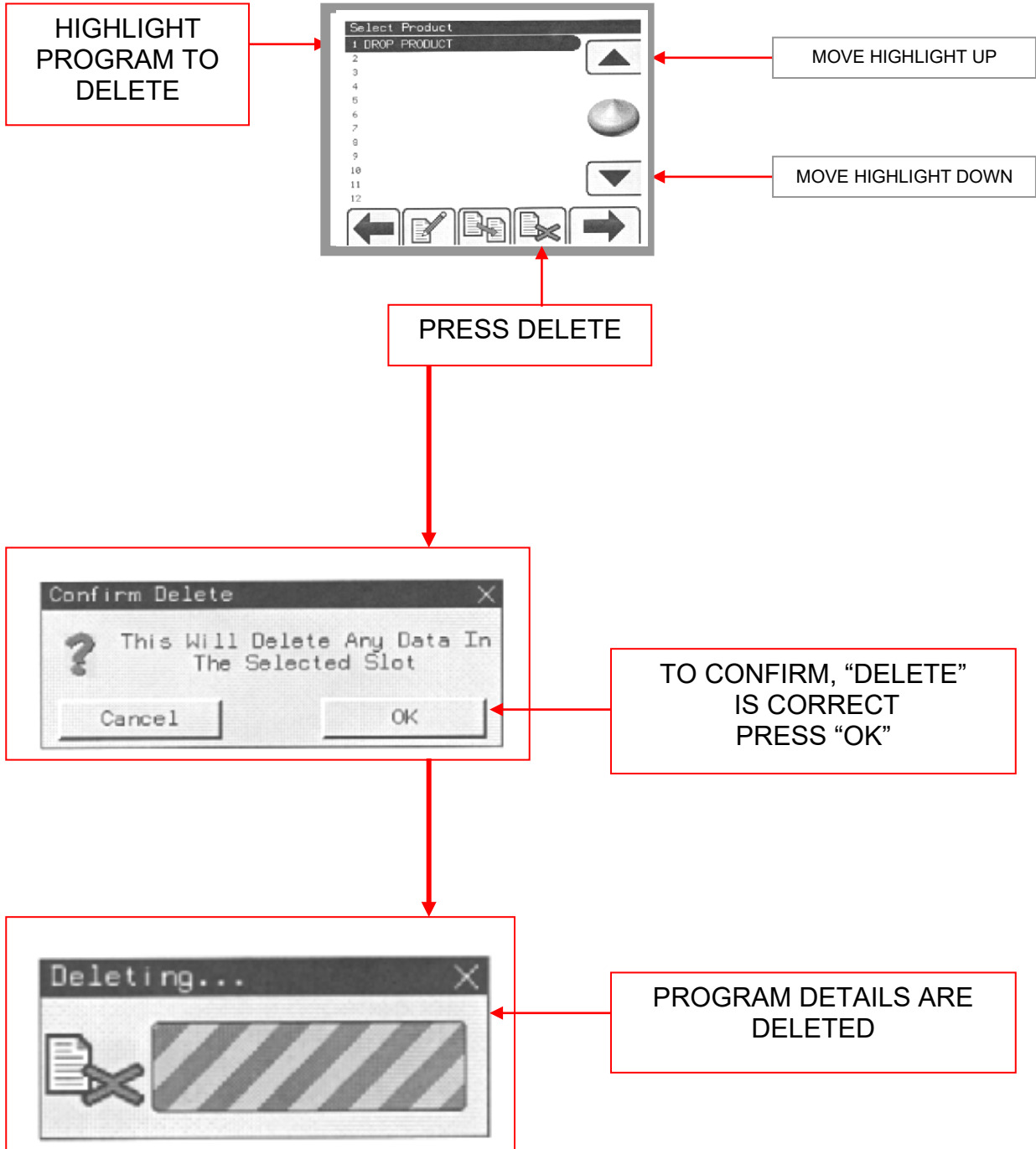

## CAUTION

DO NOT ATTEMPT TO MAKE ADJUSTMENTS UNLESS YOU ARE FULLY AWARE OF THE RESULTS

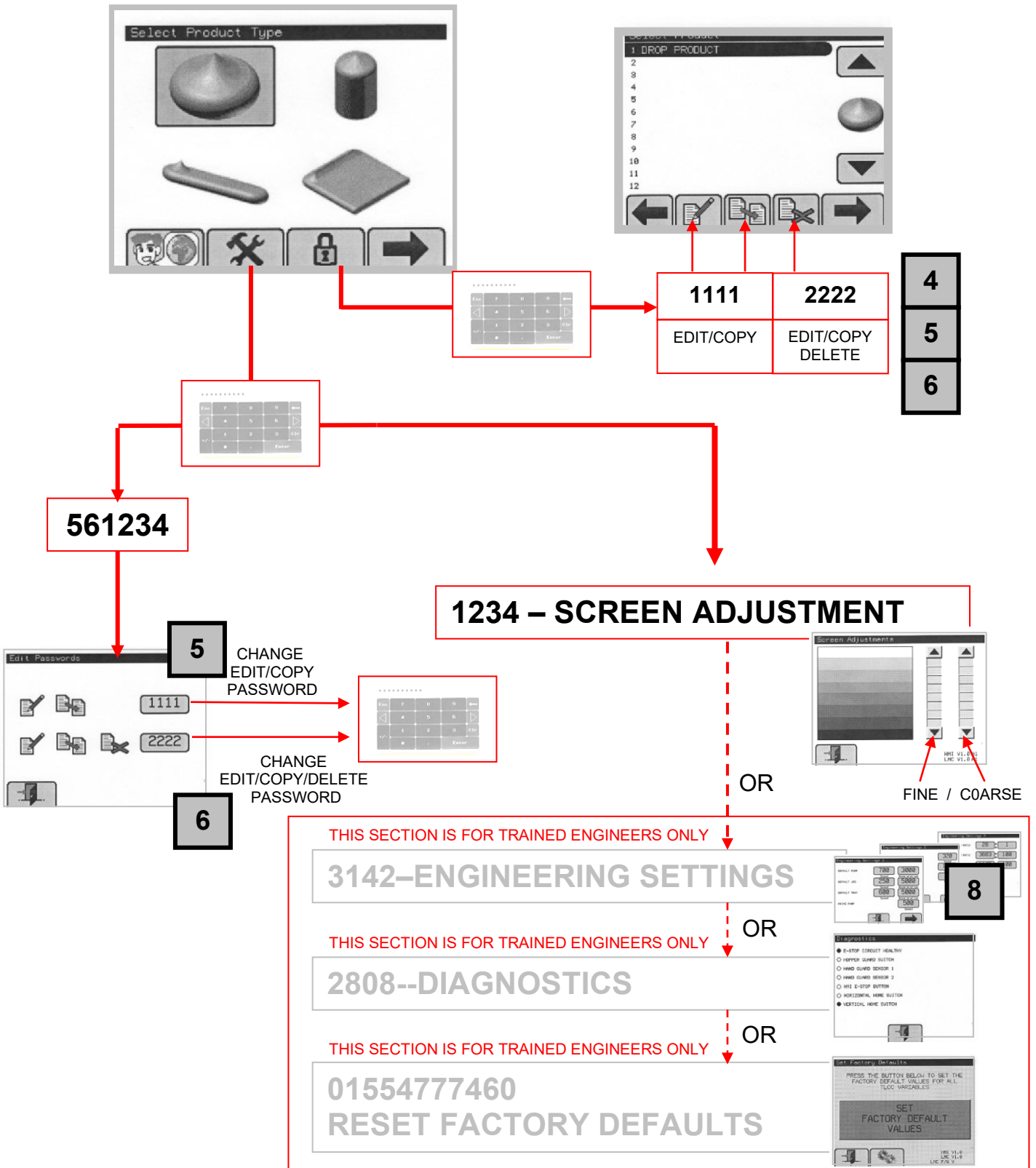

THIS SECTION IS FOR TRAINED ENGINEERS ONLY

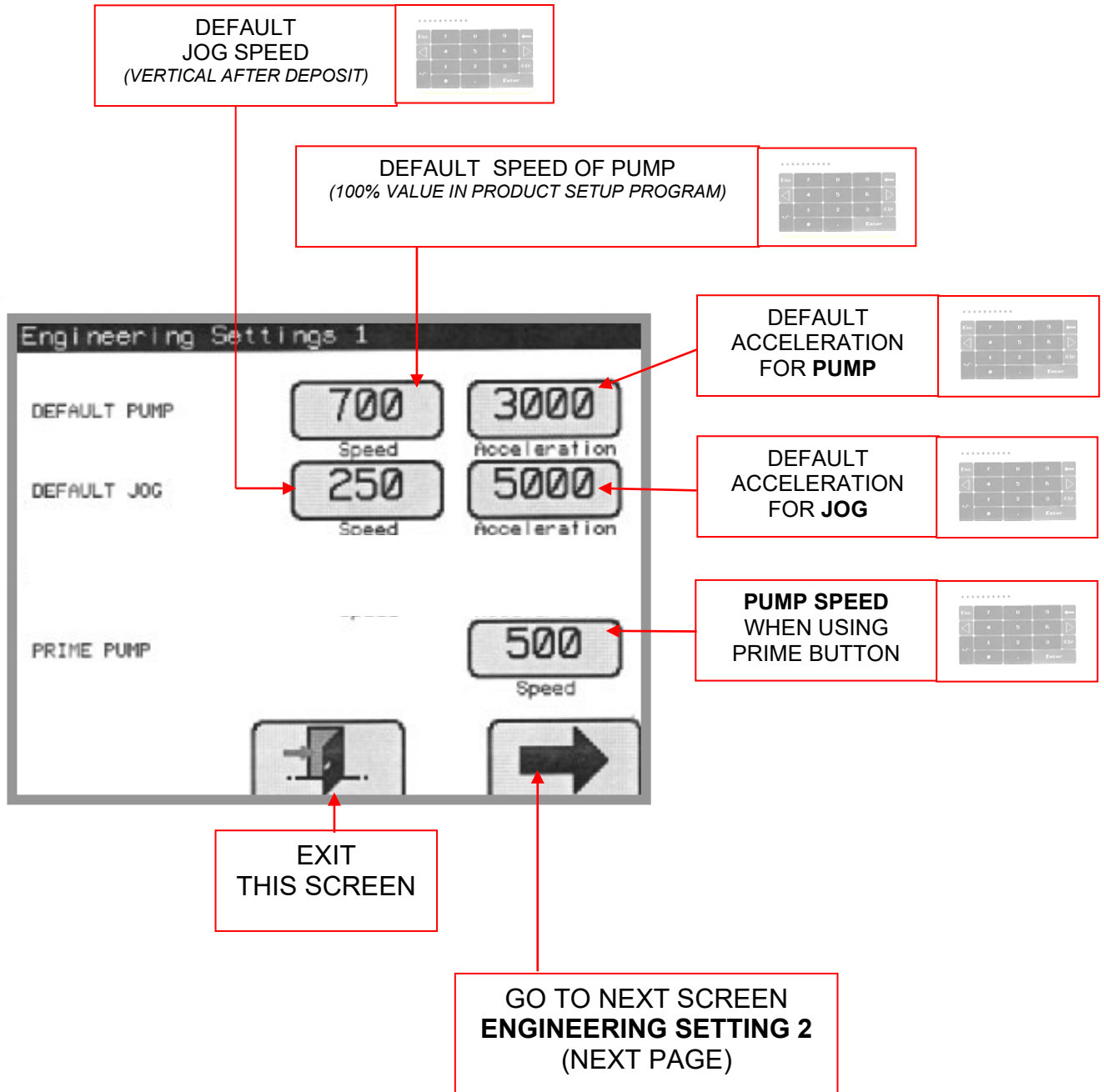

## CAUTION

**DO NOT ATTEMPT TO MAKE ADJUSTMENTS UNLESS YOU ARE FULLY AWARE OF THE RESULTS**



THIS SECTION IS FOR TRAINED ENGINEERS ONLY

## WIPE BACK DEFAULT SETTINGS (SEE 4A )

The screenshot shows the 'Engineering Settings 2' screen. It features two adjustable speed settings: 'WIPE BACK HOPPER SPEED' set to 100 and 'WIPE BACK JOG SPEED' set to 25. Both are labeled 'Speed'. Below the settings are three navigation buttons: a left arrow, a door icon, and a right arrow. Callouts provide instructions: 'HOPPER SPEED' with a double-headed arrow, 'JOG SPEED' with an up arrow, 'GO TO PREVIOUS SCREEN ENGINEERING SETTING 1 (PREVIOUS PAGE)', 'EXIT THIS SCREEN', and 'GO TO NEXT SCREEN ENGINEERING SETTING 3 (NEXT PAGE)'.

### **CAUTION**

**DO NOT ATTEMPT TO MAKE ADJUSTMENTS UNLESS YOU ARE FULLY AWARE OF THE RESULTS**

THIS SECTION IS FOR TRAINED ENGINEERS ONLY

## GEARBOX RATIOS

The screenshot shows the 'Engineering Settings 3' screen with the following data:

Setting	Value 1	Value 2
PUMP GEARBOX RATIO	28	1
TRAY GEARBOX RATIO	3683	100
JOG GEARBOX RATIO	1145	100

Navigation options at the bottom of the screen:

- GO TO PREVIOUS SCREEN  
**ENGINEERING SETTING 2**  
(PREVIOUS PAGE)
- EXIT THIS SCREEN

Labels on the right side of the image point to the values in the table:

- PUMP (points to the value 1)
- TRAY (points to the value 100)
- JOG (points to the value 100)

### **CAUTION**

**DO NOT ATTEMPT TO MAKE ADJUSTMENTS UNLESS YOU ARE FULLY AWARE OF THE RESULTS**

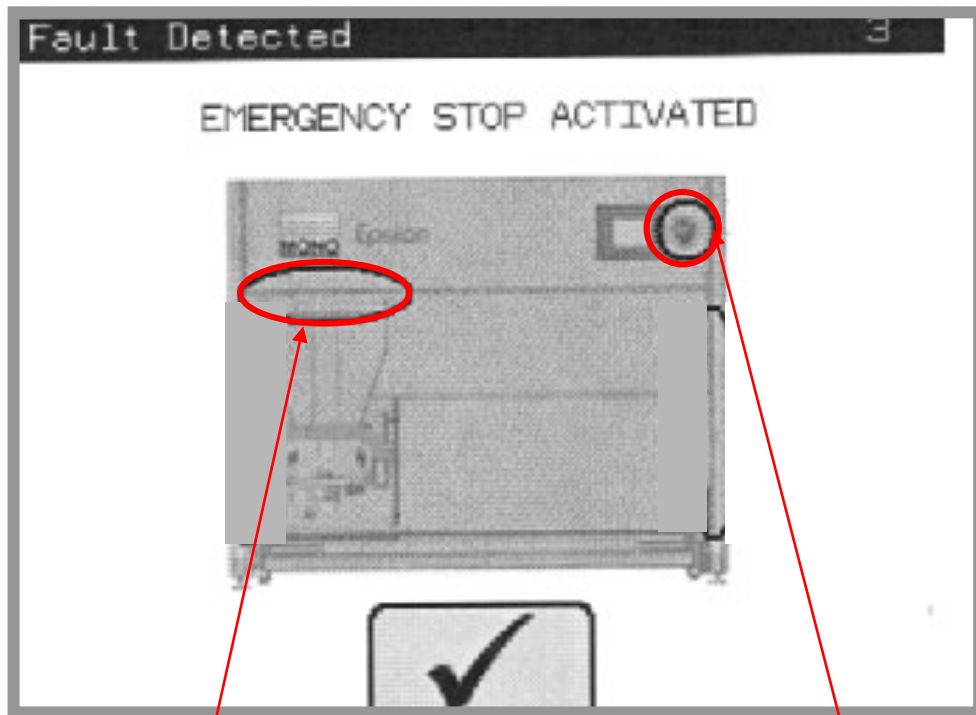

HOPPER COVER

STOP BUTTON

THIS SCREEN INDICATES A FAULT CONDITION IN THE SAFETY AREAS.

WHEN **RED**, CLOSE COVER OR CLEAR OBSTRUCTIONS TO CLEAR FAULT.  
WHEN SCREEN CLEARS, FAULT HAS BEEN CORRECTED.

PRESS  BUTTON TO CLEAR SCREEN

IF THE FOLLOWING SCREEN APPEARS, CHECK THAT THE HOOPER MOVEMENT ETC. IS NOT JAMMED WITH SOMETHING. IF IT IS, CLEAR THE OBSTRUCTION AND PRESS  TO PROCEED.

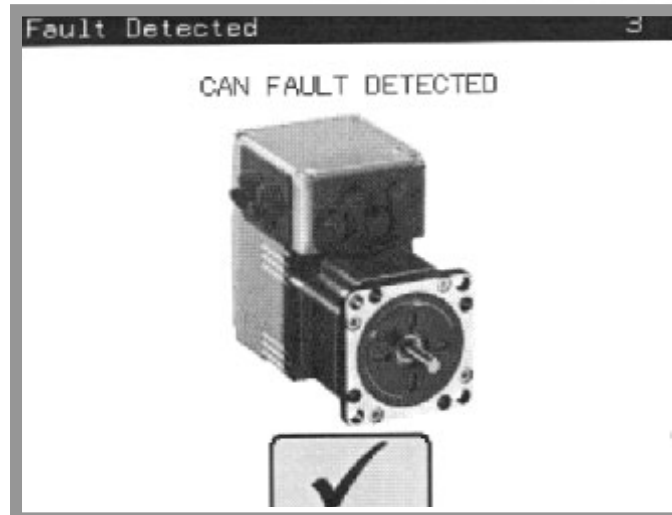

IF THE FAULT IS NOT OBVIOUS AND NOT ABLE TO BE CLEARED SAFELY, A SUITABLY TRAINED ENGINEER SHOULD BE CALLED

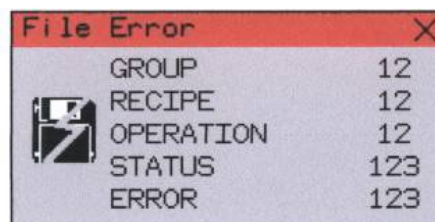

ERROR WHEN LOADING/SAVING RECIPE DATA TO HMI STORAGE CARD  
PLEASE CONTACT SERVICE DEPT. / ENGINEER IF PROBLEM PERSISTS

**WARNING**

- This appliance must be maintained at regular intervals. The frequency of maintenance will depend upon your specific use and location. The maximum service interval should be 12 months.
- Service and maintenance should only be undertaken by suitably qualified, trained, and competent engineers.
- You must immediately report any damage or defect arising with the appliance.
- Unsafe equipment is dangerous. Do not use the appliance. Isolate the power supply and contact ERIKA RECORD.

Under most conditions the machine only needs to be kept clean and used as instructed in this manual.



**WARNING: DO NOT UNDER ANY CIRCUMSTANCES  
USE A WATER HOSE OR PRESSURE WASHER TO  
CLEAN THIS MACHINE.**

If a fault arises, please do not hesitate to contact the Customer Service Department, quoting the **machine serial number** on the silver information plate of the machine and on the front cover of this manual



## SERVICE, SPARES and SUPPORT:

### ERIKA RECORD

37 Atlantic Way  
Clifton  
NJ 07012  
USA

Office: 973-614-8500  
Fax: 973-614-8503  
Toll Free: 800-682-8203

# DOUGH HOPPER PARTS

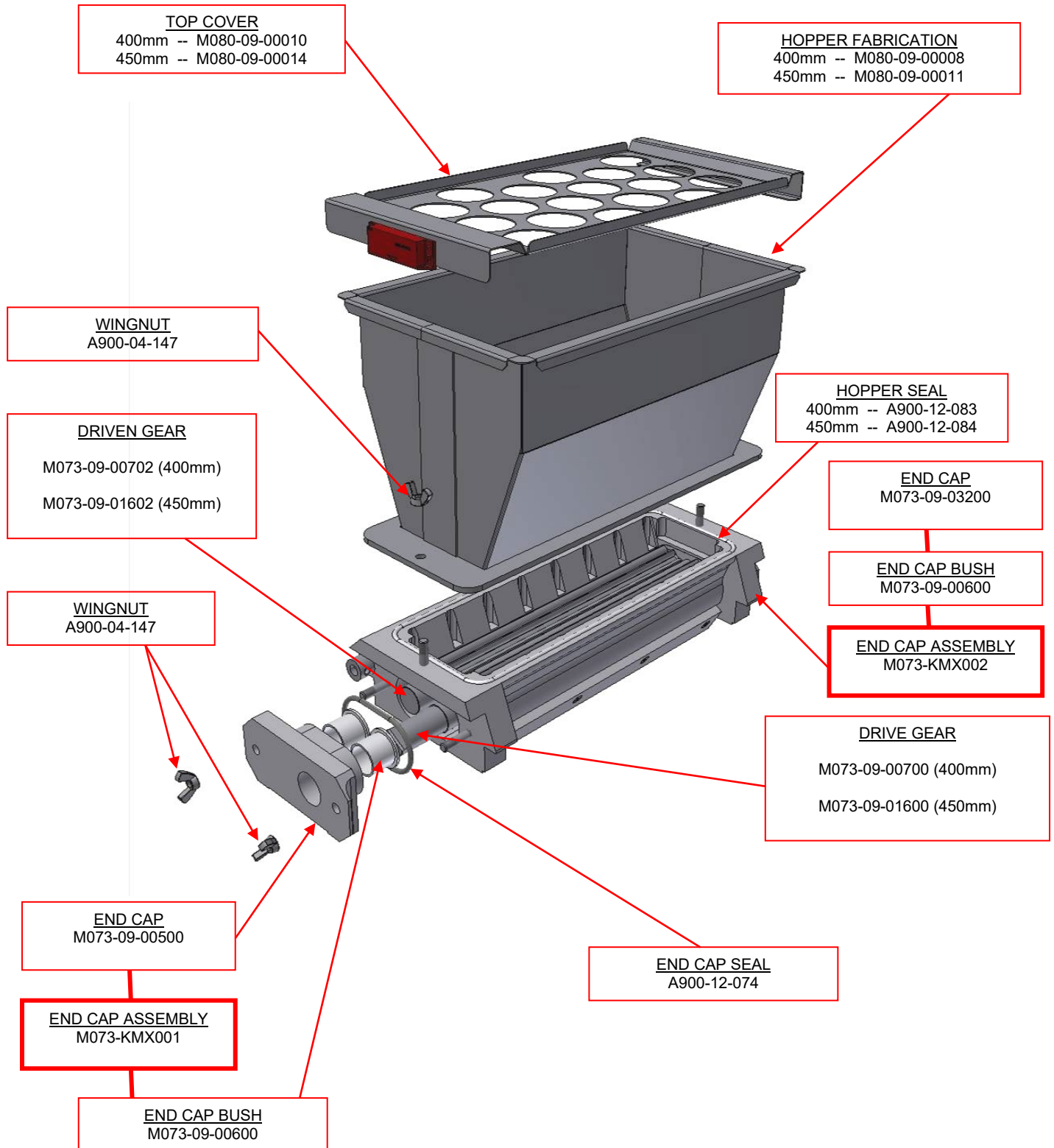

# MAIN BODY PARTS

FRONT VIEW WITH COVERS REMOVED

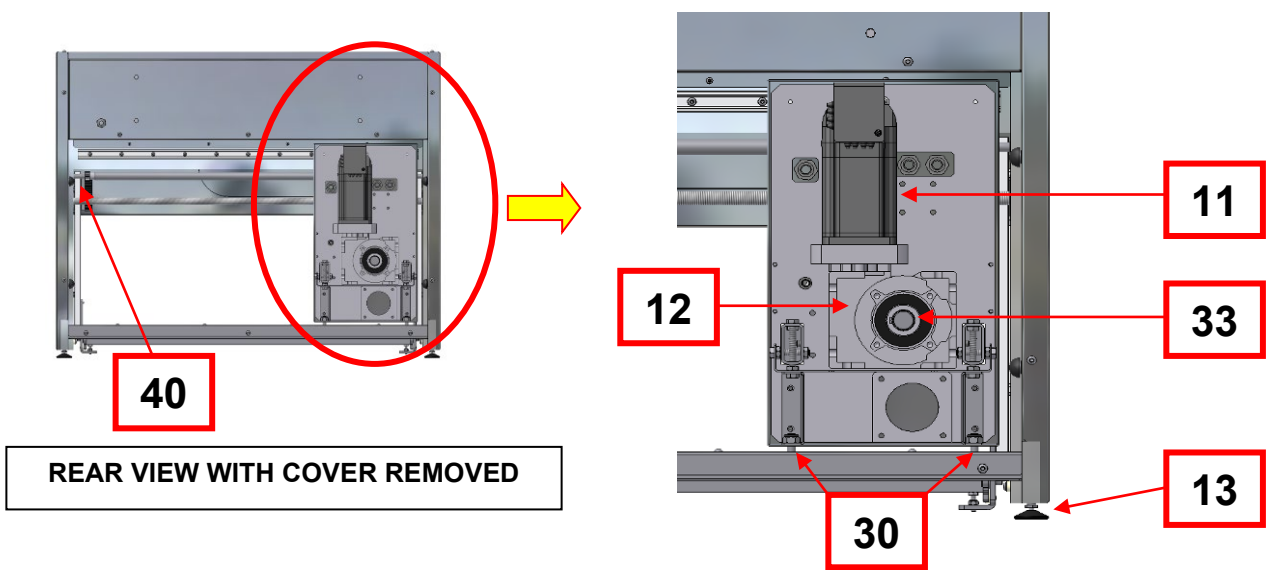
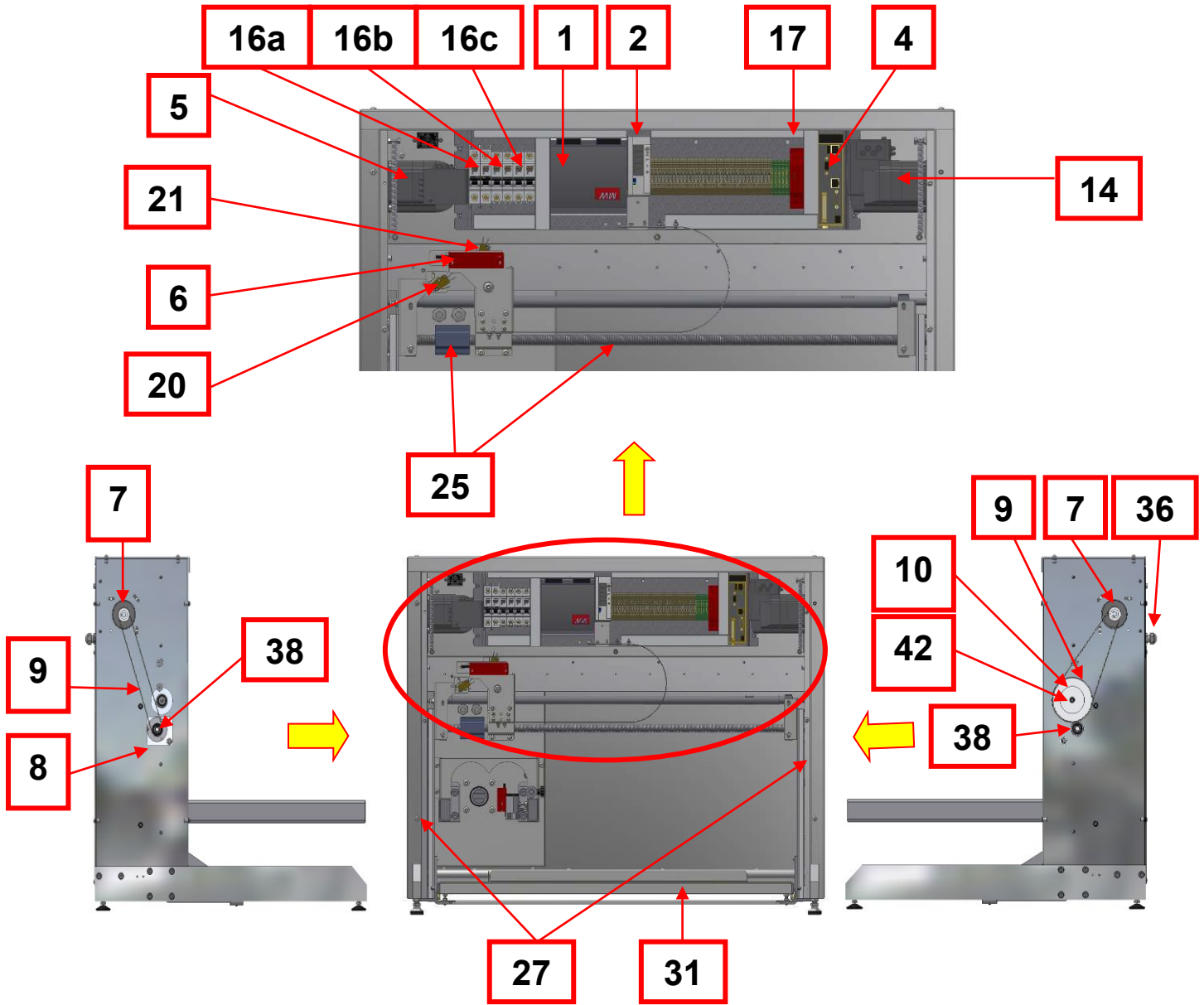

REAR VIEW WITH COVER REMOVED



3

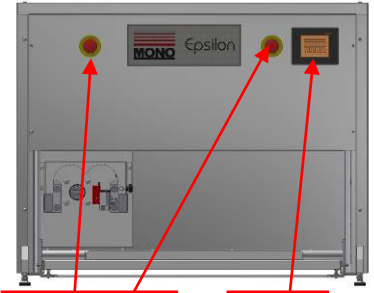
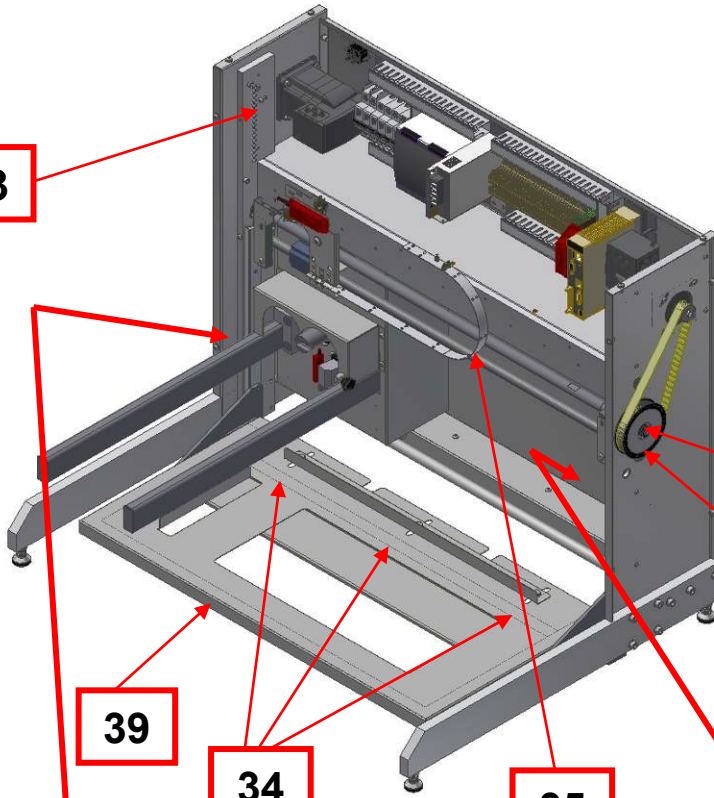

18/19

15

FRONT VIEW WITH COVERS ON

10

42

39

34

35

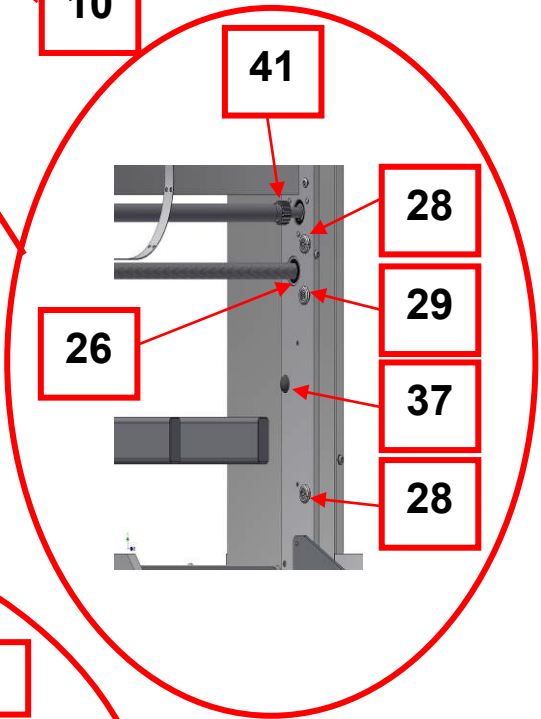

41

28

29

37

28

26

23

32

22

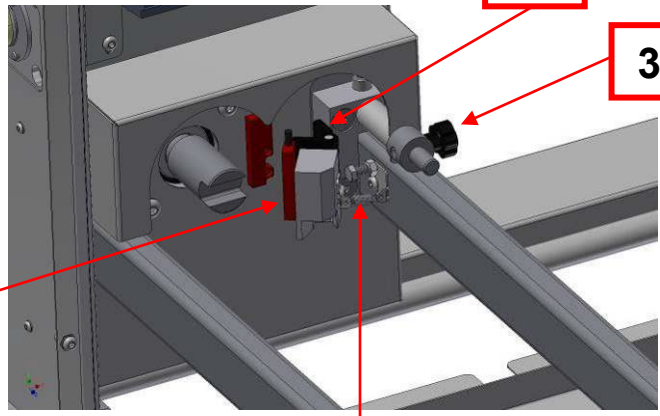

24

<u>ITEM</u>	<u>DESCRIPTION</u>	<u>PART NUMBER</u>
1.	36V POWER SUPPLY	B801-93-019
2.	24V POWER SUPPLY	B801-93-043
3.	TRAY SPRING	A900-19-021
4.	LMC20	B801-80-033
5.	TRAY MOTOR	B781-74-007
6.	SAFETY SWITCH	B801-07-005
7.	TIMING PULLEY	080-02-00026
8.	TIMING PULLEY	080-02-00020
9.	TIMING BELT	A900-21-107
10.	TIMING PULLEY	080-02-00021
11.	DEPOSIT MOTOR	B781-74-008
12.	GEARBOX	A900-11-095
13.	ADJUSTABLE FOOT	A900-27-227
14.	JOG MOTOR	B781-74-006
15.	HMI	B801-93-018
16a.	CIRCUIT BREAKER	B872-22-122
16b.	CIRCUIT BREAKER	B872-22-118
16c.	CIRCUIT BREAKER	B872-22-118
17.	E-STOP RELAY	B801-11-019
18.	STOP BUTTON	B801-12-003
19.	CONTACT BLOCK	B801-14-008 (N/C), B801-14-004 (N/O)
20.	JOG SWITCH	B842-07-029
21.	TRAY SWITCH	B842-07-030

<b>22.</b>	TEMPLATE SAFETY SWITCH/MAGNET	B801-07-006
<b>23.</b>	HINGE FOR TEMPLATE SAFETY MAGNET	A900-27-217
<b>24.</b>	RETURN SPRING	A900-19-094
<b>25.</b>	BALLSCREW + NUT	080-02-00025
<b>26.</b>	BEARING FOR BALLSCREW	A900-06-009
<b>27.</b>	VERTICAL SLIDES	A900-31-054
<b>28.</b>	V-ROLLER – CONCENTRIC	A900-06-297
<b>29.</b>	V-ROLLER – ECCENTRIC	A900-06-298
<b>30.</b>	TRACK ROLLER	A900-06-136
<b>31.</b>	TRAY GUIDE	080-08-00015
<b>32.</b>	HOPPER LOCKING THUMSCREW	A900-27-213
<b>33.</b>	CIRCLIP – HOPPER DRIVESHAFT	A900-01-193
<b>34.</b>	WINGNUT FOR TRAY GUIDE	A900-04-043
<b>35.</b>	CABLE GUIDE STRAP	080-25-00006
<b>36.</b>	MAINS INLET	B842-06-031
<b>37.</b>	BUMP STOPS	A900-18-006
<b>38.</b>	CIRCLIPS – BALLSCREW	A900-01-112
<b>39.</b>	PLATFORM FABRICATION (400 HOPPER VERSION) =	080-08-00001 080-08-00011
<b>40.</b>	RACK	080-02-00032
<b>41.</b>	PINION	080-02-00032
<b>42.</b>	TRANS-TORQUE BUSH	A900-10-011



## **14.0 ELECTRICAL INFORMATION**

# **EPSILON**

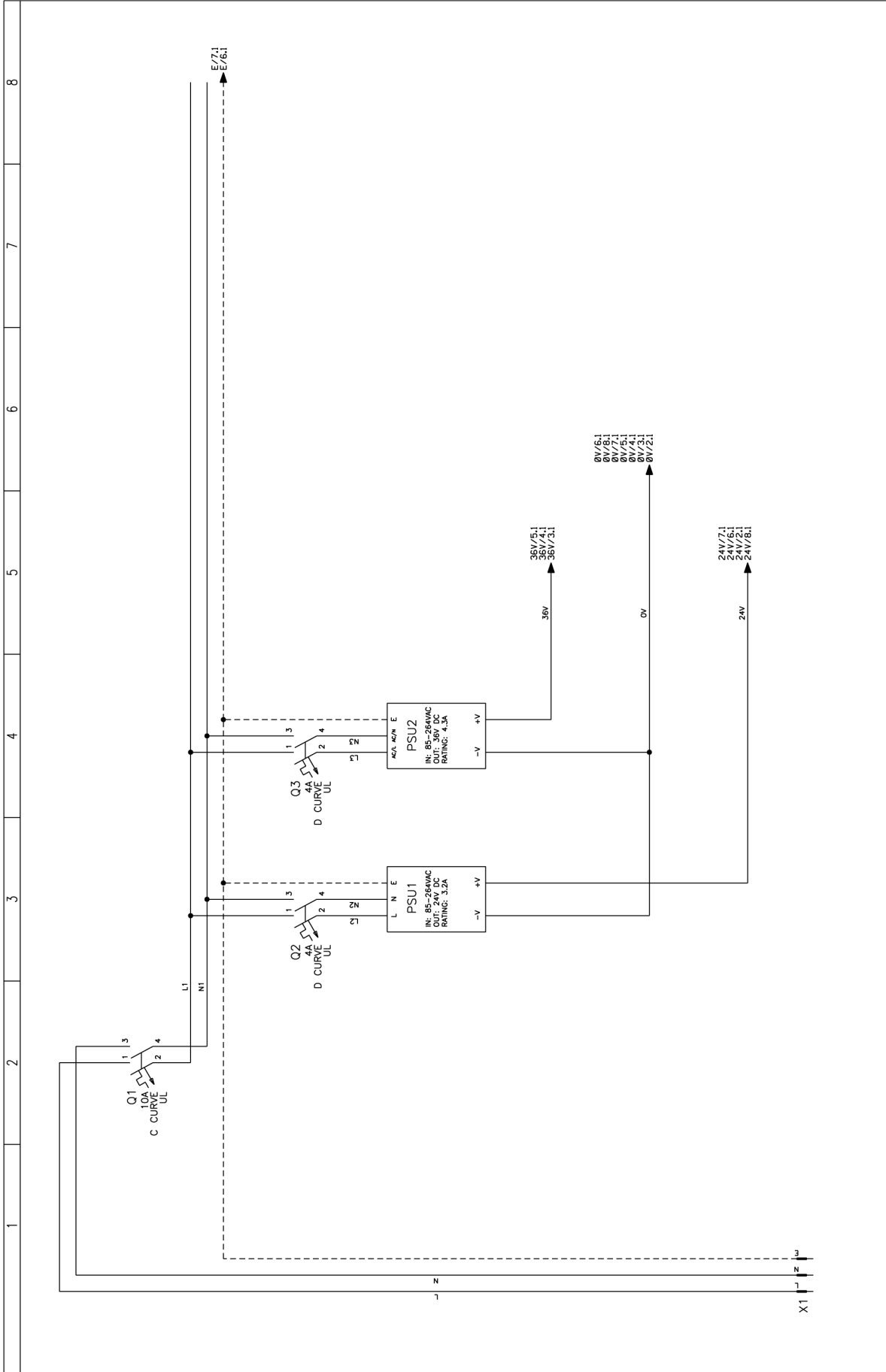

MONO EQUIPMENT SWANSEA WEST IND PARK SWANSEA TEL: (01792) 567234 www.monoequip.com FAX: (01792) 351016		ELECTRICAL DISTRIBUTION		BY DATE REV DATE REV BY NOTES		ECN NO.	
PROJECT DESCRIPTION EPSILON DEPOSITOR UL SPECIFICATION		DRAWN RO 08/07/21 A 08/07/21 RO AS BUILT					
PROJECT EPSILON_MK2C_UL		APPROVED		ELECTRICAL SPECIFICATIONS 120/240VAC 1PH+N+E 50/60HZ		DRAWING NUMBER 080E25-00055	
TITLE ELECTRICAL DISTRIBUTION		INSTALLATION LOCATION PANEL		ELECTRICALLY APPROVED BY ANGELA THOMAS		PAGE 1 OF 8	
COPYRIGHT © 1988 - THIS DESIGN/DRAWING IS THE PROPERTY OF MONO EQUIPMENT LTD. AND MUST NOT BE REPRODUCED, COPIED, NOR ITS CONTENTS DIVULGED WITHOUT PRIOR WRITTEN PERMISSION.						REV A	

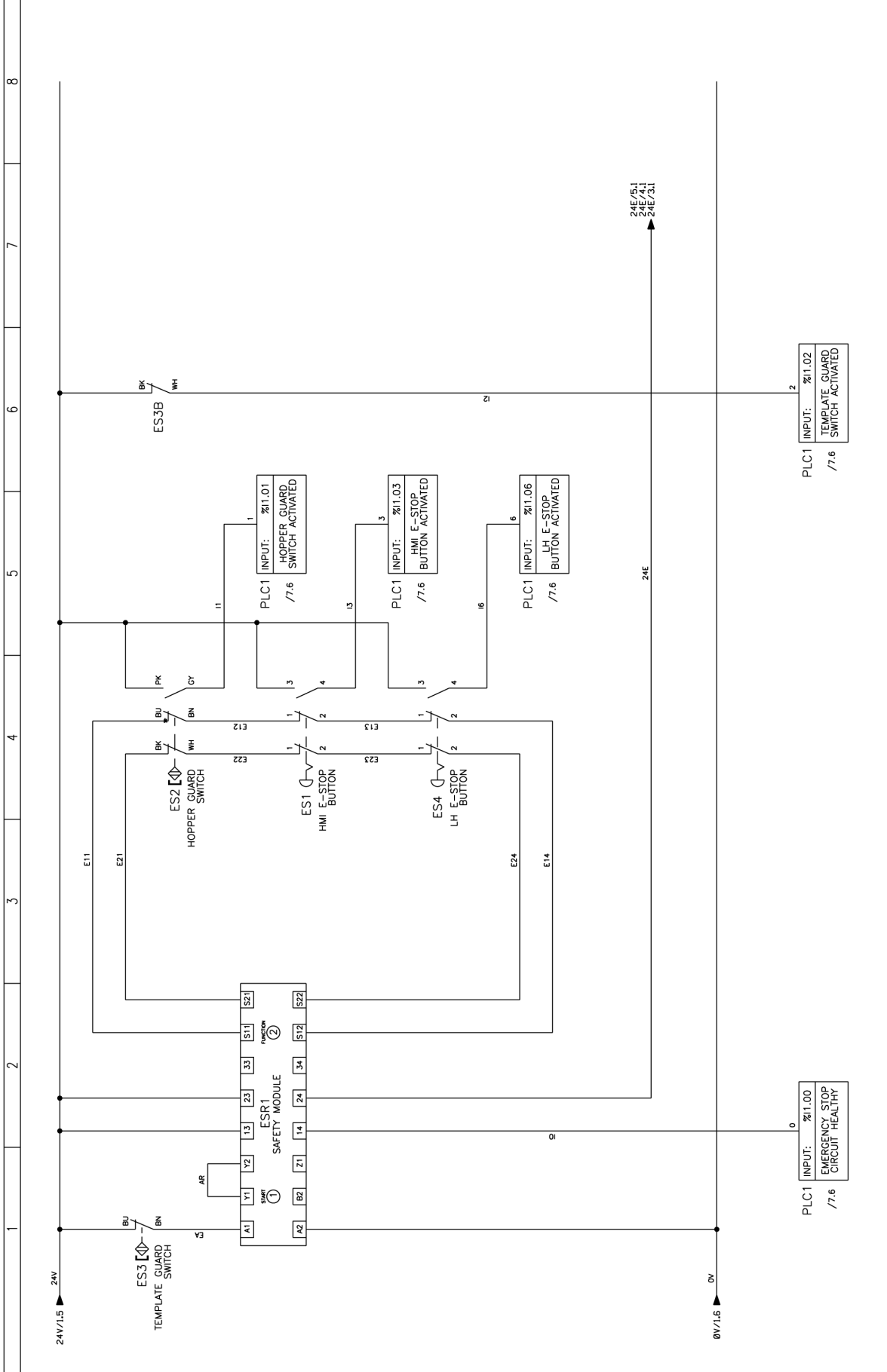

MONO EQUIPMENT DUNSWAY WEST IND PARK SWANSEA SAS 7LEB 031 561924 www.monoequip.com FAX 01792 551016		PROJECT DESCRIPTION EPSILON DEPOSITOR UL SPECIFICATION		PROJECT EPSILON_MK2C_UL		TITLE SAFETY CIRCUIT		ELECTRICAL SPECIFICATIONS 120/240VAC 1PH+1N+E 50/60HZ		DRAWING NUMBER 080E25-0006		PAGE 2 OF 8		REV A	
BY	DATE	REV	DATE	BY	DATE	REV	DATE	NOTES							
RO	08/07/21	A	08/07/21	RO	AS BUILT										
APPROVED				APPROVED											
INSTALLATION				INSTALLATION											
LOCATION				LOCATION											
ELECTRICALLY APPROVED BY: ANGELA THOMAS															

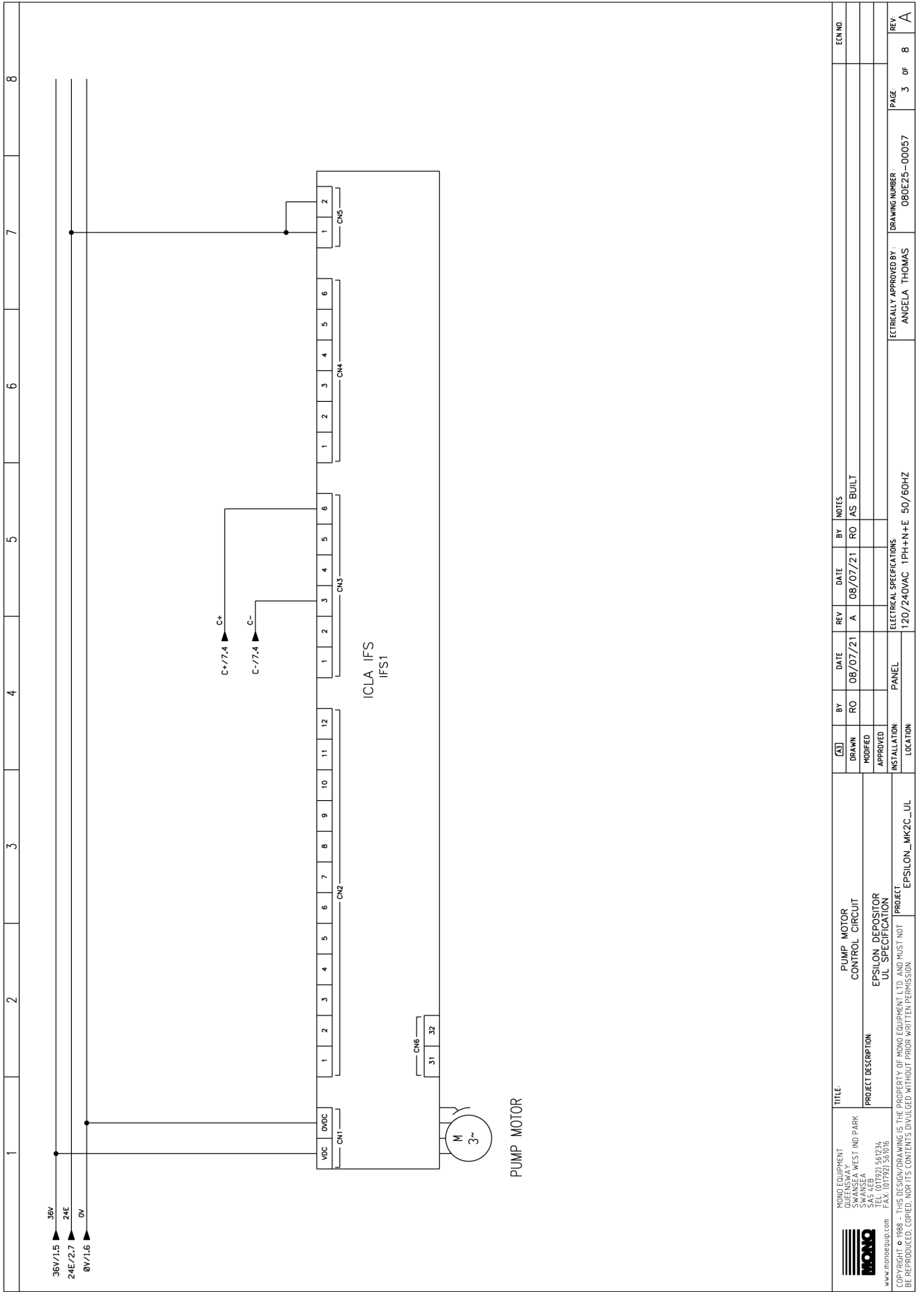

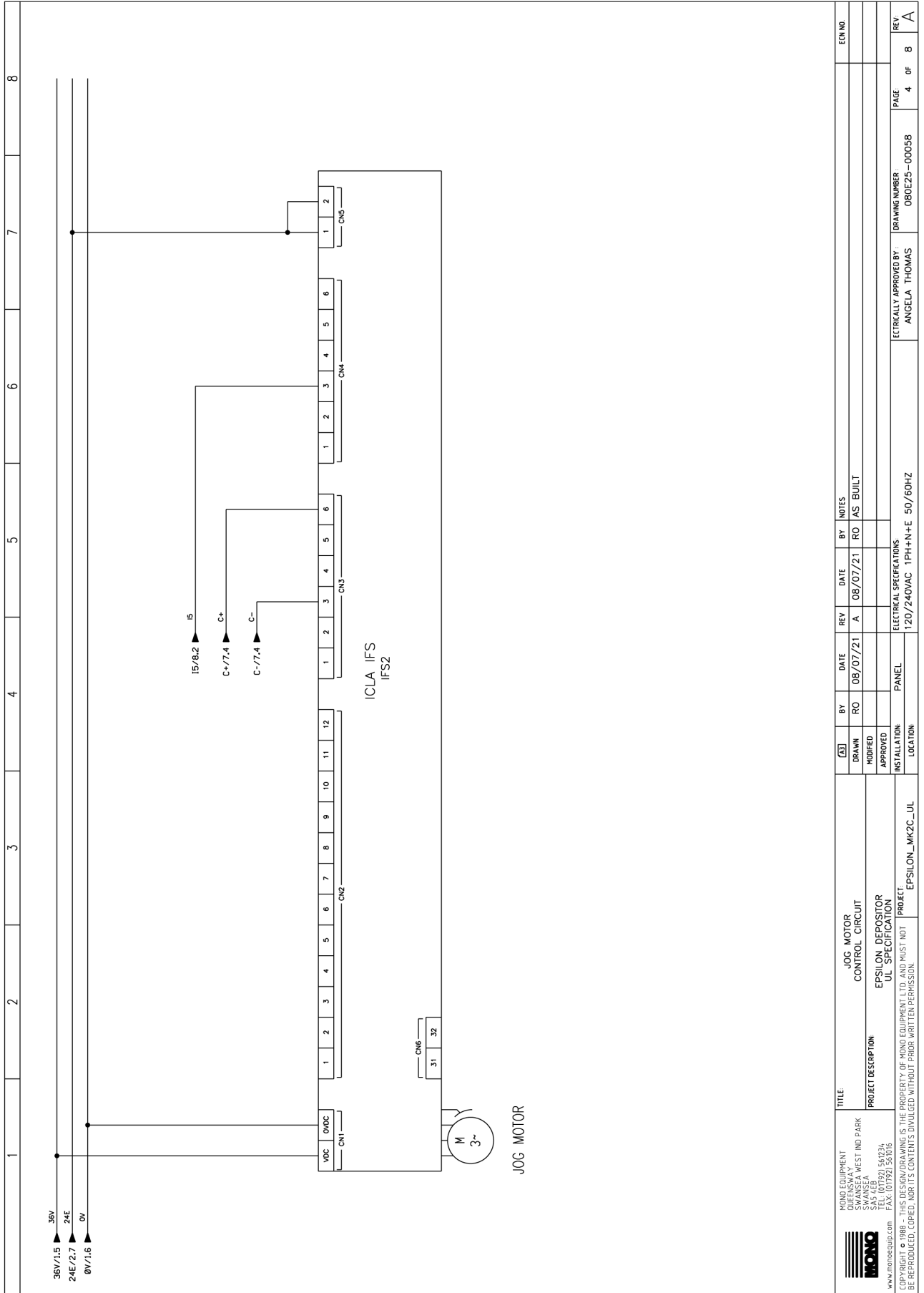

MONO EQUIPMENT		TITLE		REV		DATE		BY		NOTES		ECN NO	
MONO EQUIPMENT SWANSEA WEST IND PARK SWANSEA MASSACHUSETTS 01906 TEL: (01792) 561234 FAX: (01792) 561016 www.monoequip.com		JOG MOTOR CONTROL CIRCUIT		A		08/07/21		RO		AS BUILT			
PROJECT DESCRIPTION		EPSILON DEPOSITOR UL SPECIFICATION		DRAWN		MODIFIED		APPROVED		ELECTRICAL SPECIFICATIONS		DRAWING NUMBER	
PROJECT		EPSILON_MK2C_UL		INSTALLATION		LOCATION		PANEL		ELECTRICAL SPECIFICATIONS		080E23-00058	
COPYRIGHT © 1988 - THIS DESIGN/DRAWING IS THE PROPERTY OF MONO EQUIPMENT LTD. AND MUST NOT BE REPRODUCED, COPIED, NOR ITS CONTENTS DIVULGED WITHOUT PRIOR WRITTEN PERMISSION.						120/240VAC 1PH+N+E 50/60HZ		ANGELA THOMAS		REVISIONS		PAGE 4 of 8	
												REV. 8	



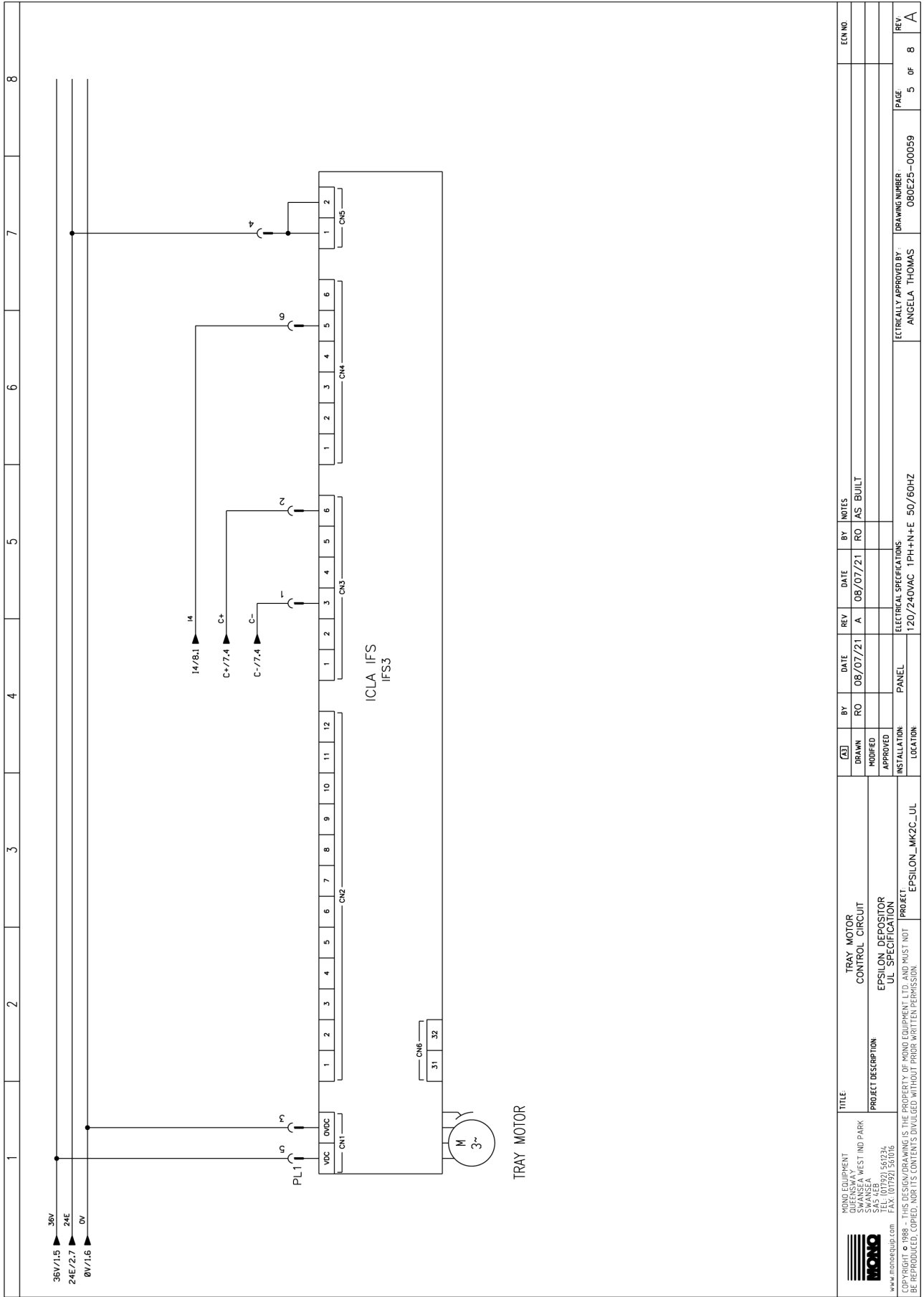

MONO EQUIPMENT QUENSWAY WEST IND PARK SWANSEA SA5 4EB TEL: 01792 561734 FAX: 01792 561016 www.monoequip.com		TITLE TRAY MOTOR CONTROL CIRCUIT		BY RO		DATE 08/07/21		REV A		NOTES RO AS BUILT		ECN NO	
PROJECT DESCRIPTION EPSILON DEPOSITOR UL SPECIFICATION		PROJECT EPSILON_MK2C_UL		DRAWN		MODIFIED		APPROVED		ELECTRICAL SPECIFICATIONS 120/240VAC 1PH+N+E 50/60HZ		PAGE 5 OF 8	
COPYRIGHT © 1988 - THIS DESIGN/DRAWING IS THE PROPERTY OF MONO EQUIPMENT LTD. AND MUST NOT BE REPRODUCED, COPIED, NOR ITS CONTENTS DIVULGED WITHOUT PRIOR WRITTEN PERMISSION.		INSTALLATION LOCATION		ELECTRICALLY APPROVED BY ANGELA THOMAS		DRAWING NUMBER 080E25-00059		REV A					

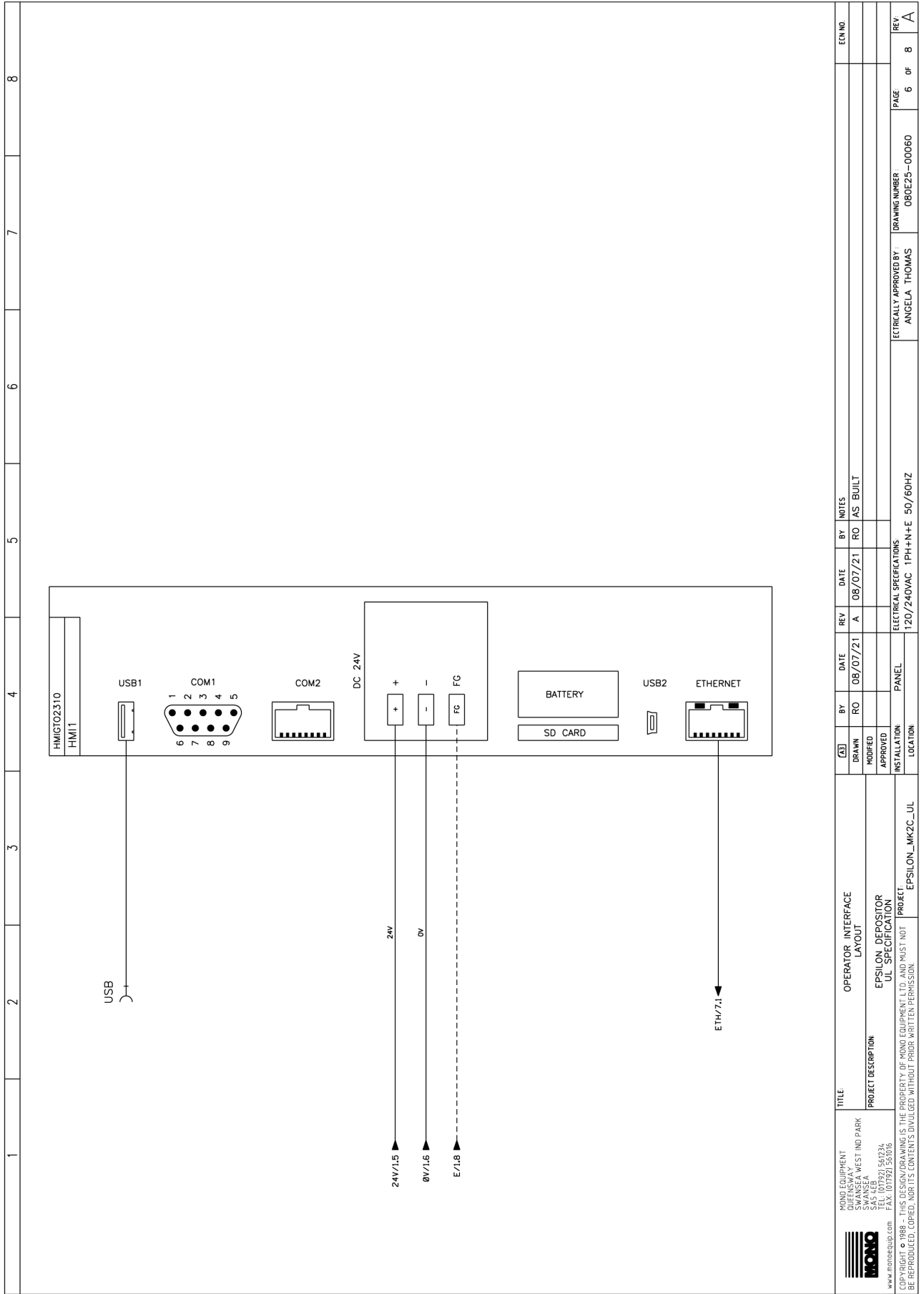

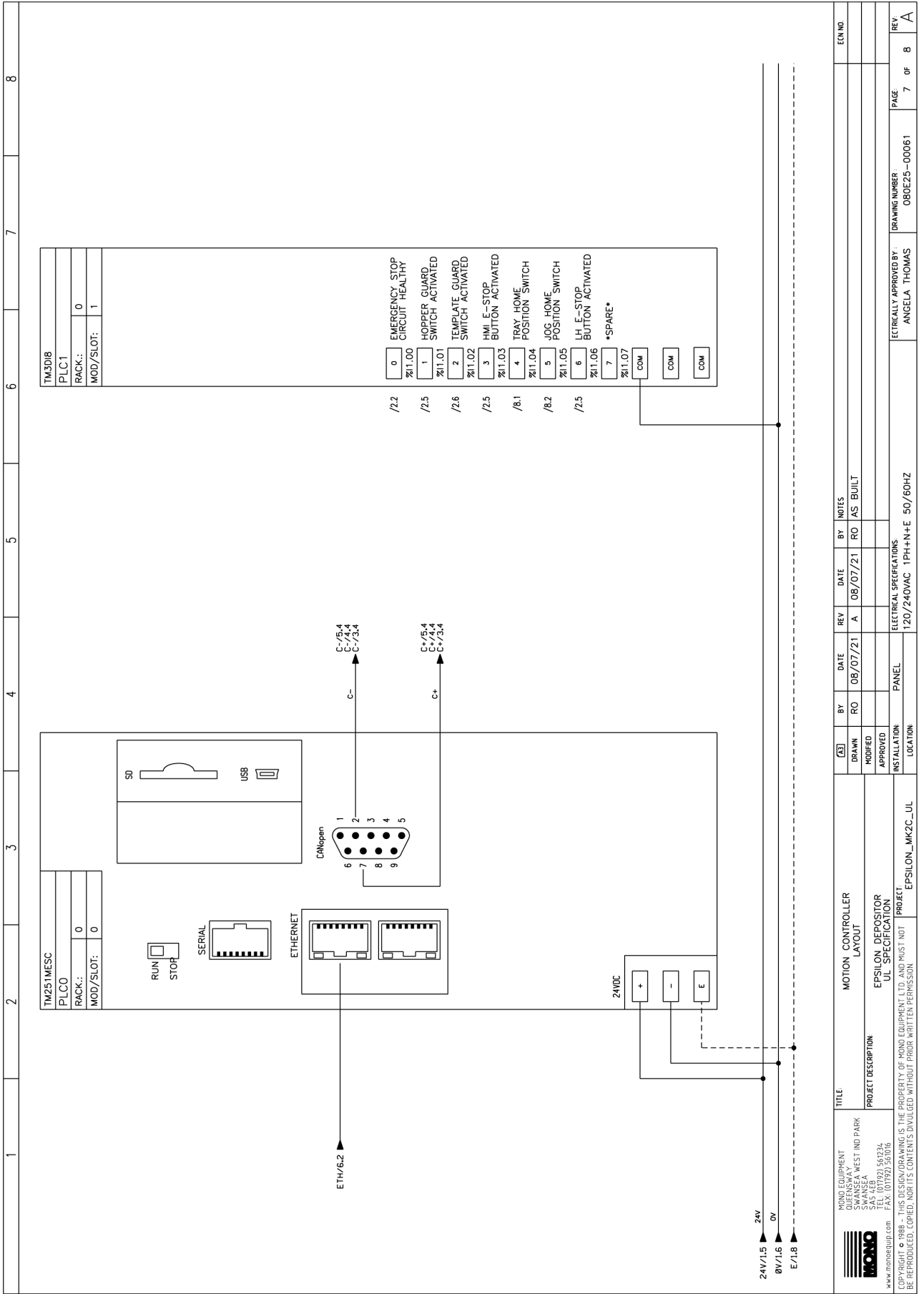

MONO EQUIPMENT		MOTION CONTROLLER		BY		DATE		REV		NOTES		ECN NO	
SWANSEA WEST IND PARK		LAYOUT		RO		08/07/21		A		RO AS BUILT			
PROJECT DESCRIPTION		EPLSON DEPOSITOR		DRAWN		DATE		REV		BY		ECN NO	
UL SPECIFICATION		UL SPECIFICATION		MODIFIED		08/07/21		A		RO AS BUILT			
www.monoequip.com		PROJECT		APPROVED		ELECTRICAL SPECIFICATIONS		ELECTRICAL SPECIFICATIONS		ETRICALLY APPROVED BY		REV	
COPYRIGHT © 1988 - THIS DESIGN/DRAWING IS THE PROPERTY OF MONO EQUIPMENT LTD. AND MUST NOT BE REPRODUCED, COPIED, NOR ITS CONTENTS DIVULGED WITHOUT PRIOR WRITTEN PERMISSION.		EPLSON_MK2C_UL		INSTALLATION LOCATION		PANEL		120V/240VAC 1PH+N+E 50/60HZ		ANGELA THOMAS		PAGE	
										OBREZ5-00061		7 of 8	
												8	

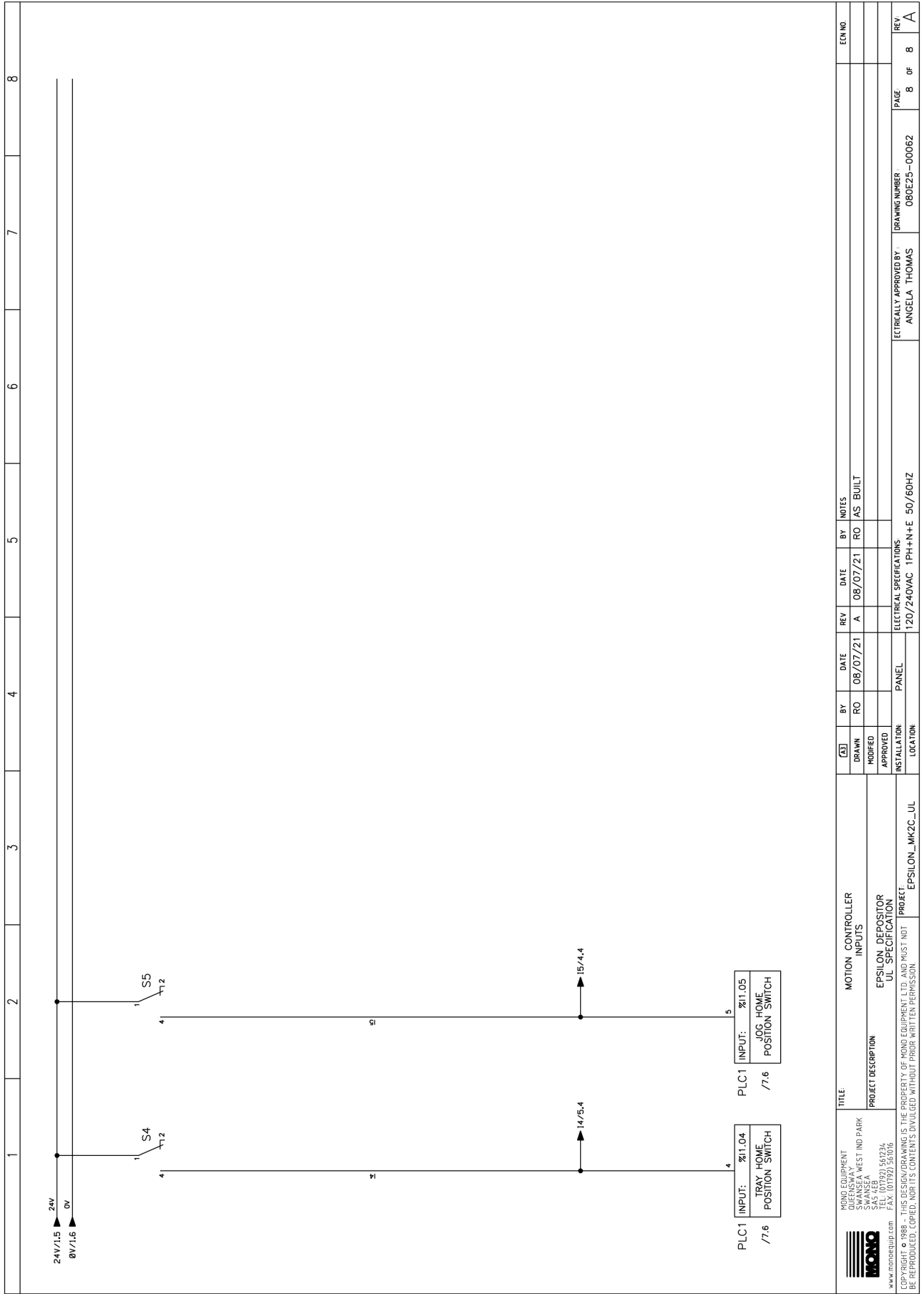

1	2	3	4	5	6	7	8
---	---	---	---	---	---	---	---

		<b>TITLE:</b> MOTION CONTROLLER INPUTS		<b>REV</b>		<b>DATE</b>		<b>BY</b>		<b>NOTES</b>		<b>ECN NO.</b>	
MONO EQUIPMENT SWANSEA WEST IND PARK SWANSEA WILTSHIRE www.monoequip.com		<b>PROJECT DESCRIPTION:</b> EPSILON DEPOSITOR UL SPECIFICATION		DRAWN RO		08/07/21		RO		AS BUILT			
COPYRIGHT © 1988 - THIS DESIGN/DRAWING IS THE PROPERTY OF MONO EQUIPMENT LTD. AND MUST NOT BE REPRODUCED, COPIED, NOR ITS CONTENTS DIVULGED WITHOUT PRIOR WRITTEN PERMISSION.		<b>PROJECT:</b> EPSILON_MK2C_UL		APPROVED PANEL		ELECTRICAL SPECIFICATIONS 120/240VAC 1PH+N+E 50/60HZ		ELECTRICALLY APPROVED BY: ANGELA THOMAS		DRAWING NUMBER 080E25-00062		PAGE 8 OF 8	
												REV 8 OF 8 A	



As it is our policy to improve our machines continuously, we reserve the right to change specifications without prior notice.

# Epsilon



## **ERIKA RECORD**

37 Atlantic Way  
Clifton  
NJ 07012  
USA

Office: 973-614-8500  
Fax: 973-614-8503  
Toll Free: 800-682-8203

## **DISPOSAL**

Care should be taken when the machine comes to the end of its working life. All parts should be disposed of in the appropriate place, either recycling or other means as the law permits at the time.