

Innovative equipment  
for traditional baking



# Εpsilon Tabletop

CONFECTIONERY DEPOSITOR



## INTERESTING FACT:

### History of the Eclair

Without doubt the most famous pastry in the world is the French éclair and its name means 'flash of lightening', which many pastry makers say because the éclair is eaten 'in a flash'. It is thought that Antoine-Carême, a famous pastry chef for French royalty created the éclair around the beginning of the nineteenth century in France. Carême was the chef who baked Napoleon's wedding cake and created gastronomic masterpieces for the Prince de Talleyrand at the Chateau of Valencay.

Eclairs were first known as 'pain à la duchesse' or 'petite duchesse', French terms meaning 'bread duchess' and 'little duchess' respectively, whilst Oxford English Dictionary traces the term 'éclair' in the English language to 1861. The first known recipe for eclairs appeared in the Boston Cooking School Cook Book by Mrs D.A Lincoln, published in 1884.

The term 'pâtisserie' derives from French pastries and the shops they are sold in. By law, shops in France and Belgium are only allowed to use the term if they employ a licensed master pâtissier.

A true éclair is a long, thin pastry made with choux pastry filled with a cream and topped with icing. The most popular version is the chocolate éclair and there is even a National day devoted to the chocolate éclair in the USA.



## One of the Smallest Depositors Available



In recent years the world of patisserie has experienced a great revival due to the explosion of celebrity baking programmes on TV and a genuine adoration of all things nostalgic.

Producing these mouth-watering delights could not be simpler using MONO Equipment's Epsilon Tabletop Confectionery Depositor, which can effortlessly produce an almost endless array of superb quality cakes and confectionery products with consistency and accuracy.



Requiring less than 1m<sup>2</sup> of space in which to operate, the Epsilon Tabletop Confectionery Depositor is the smallest depositor in our range and is perfectly suited to environments that have limited space such as:

- Patisseries
- Cake Shops
- Hotels and Restaurants
- Airline Caterers
- Bakeries
- Supermarkets
- Institutional Caterers
- Cruise Ships

Requiring just one person to set up and operate, this fully-automated depositor will accurately deposit approximately 18 rows (product dependent) per minute.

Thanks to the unique travelling hopper system, the machine deposits with pin-point accuracy. The trays are loaded directly from the front of the machine, significantly reducing the space needed to operate the machine.

The craftsmanship that goes into each built-to-order Epsilon Depositor ensures that these machines are built to last. The copious amount of stainless steel used in their manufacture also guarantees them to be durable, hygienic and easy to clean.

### 7 Superb Features

- Innovative travelling hopper system reduces space required
- Ergonomic front-loading system reduces operator strain and improves efficiency
- Pour-through hopper for quick and easy filling
- User Friendly Touch Screen controller
- Two sizes available to fit up to 400mm and 450mm wide trays
- Incorporates 15 international languages
- Stores up to 96 programmes

### 7 Superb Facts

- Fits through a standard door way
- Less than 1 square metre of space needed to operate
- Single phase 'Plug & Play' means immediate productivity
- Quick and simple product, hopper and template changeover
- Quick and easy one person set up and operation
- Suitable for soft mixes
- Provides total control of product weight, size, height, length and shape

## Simple and Intuitive Colour Touch Screen Controller

The colour touch screen control panel of the Epsilon Tabletop Confectionery Depositor makes even the most complex products simple to program and easy to run. The four menu icons on the main screen each represents a different product type that can be produced;



### Drop

- Suitable for meringue drops, macarons, choux buns, cupcakes, fairy cakes, muffins etc.



### Tower

- Suitable for creating tall tower-like products.



### Strip

- Suitable for eclairs, sponge fingers etc.



### Sheeting

- Suitable for sponge sheets, Swiss roll, angel cake, Genoese, brownies, tray bakes.

The simple tray set-up screen allows you to select the number of rows required and the distance between the rows on a tray. Product height, shape and volume can also be quickly and easily changed together with the depositing speed.

Once the values have been input, they can be named and saved as a Product Recipe Programme for future recall and use. The touch-sensitive colour touch screen controller can store up to 96 unique product programmes.

To maximise the productivity and efficiency of the depositor, the direction of the hopper travel can also be programmed to deposit in one direction only, or in both directions.

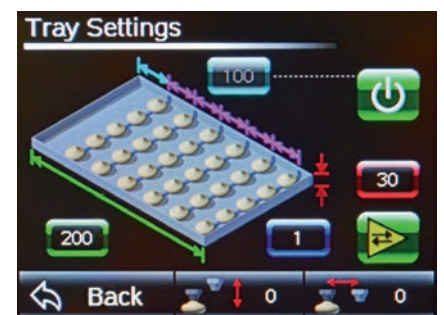

Tray set up screen

# Templates



## Standard Template

One of the most widely used templates is the highly versatile Standard Template which, when used in conjunction with a comprehensive range of plastic nozzles, can produce a large variety of product formats including drops, strips and shells along with cupcakes and multi-layered novelty products like snowmen (multiple passes required). The template is available with a range of different outlets to suit your particular needs and it can also be tailored to match your cupcake/muffin tray capacity.

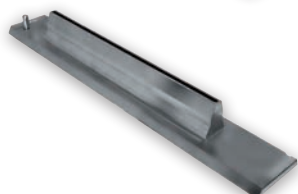

## Sheeting Template

The Sheeting Template is perfect for laying down a single deposit of mix onto a baking tray. The actual quantity of mix deposited can be pre-programmed to achieve the desired sheet thickness for creating the ultimate Swiss roll, roulade or chocolate brownies.

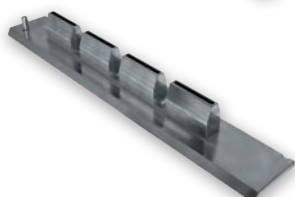

## Multi-Sheeting Template

The Multi-Sheeting Template provides the perfect solution when a number of separate deposits are required across the baking tray, or for filling smaller individual tray bakes held on a larger transport tray. The length, position and gap of each sheeting slot can be designed to your exact requirements.



## Staggered Template

The Staggered Template has been designed to make the depositing of mixes like sponge in to round cakes tins as efficient as possible. The tins are arranged on a baking tray in a triangular formation to maximise the use of space enabling three tins to be filled simultaneously - effectively filling two rows of tins in one pass.



## Heart Shaped Template

The Heart Shaped Template has been designed specifically to create heart shaped macarons. The template is manufactured from a solid piece of aluminium and the dies are simply attached to each outlet with corner screws. The number of outlets across the template depends on the size of the Epsilon.

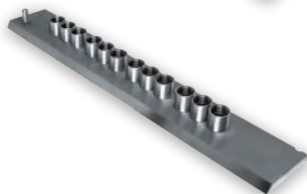

## Cluster Template

The Cluster Template can be designed with groups of 2, 3, 4 or more outlets across the template to produce a variety of innovative new products using macaron, pate a choux and meringue mixes to name but a few. The Cluster Template creates groups of connected drops.



Round: 6mm



Round: 10mm



Round: 13mm



6-Star: 6mm



8-Star: 6mm



8-Star: 10mm



8-Star: 13mm

## Plastic Nozzles

The Plastic Nozzles are simply screwed in to the Standard and Cluster Template to deposit soft mixes with a perfect finish and are available in two different formats - round and star - in a variety of different sizes to suit most products.

When depositing products like meringue drops and sponge fingers, where a velvety smooth, even finish is needed, the round shaped nozzles should be used. However, the star shaped nozzles produce superb channels on products like Viennese fingers and add depth and character to multi-layered products like Christmas trees.

## Technical Specifications

Specifications	Epsilon 400	Epsilon 450
Fits tray sizes (mm)	400 x 600	450 x 762
Height (mm) H	785	785
Height to hopper (mm)	550	550
Depth (mm) B	742	790
Width (mm) A	977	1139
Area of base (m <sup>2</sup> )	0.714	0.825
Height of control panel (mm)	700	700
Weight with soft mix hopper fitted (kg)	100	110
Cycles per minute	16*	16*
Hopper capacity soft mix (litre)	20	22.5
Maximum height of deposited product (mm)	52	52
Maximum height of travel (mm)	80	80
Maximum programme storage	96	96
Number of languages	15	15
<b>Electrics:</b>		
Power	Single phase, 13A maximum load. Suitable for 110v, 200v, 220v, 230v and 240v, 50-60Hz, IP53 maximum, no isolator	
Total Power Required (kW)	2.5	
Noise level	Less than 85db	

\* based on 5 across, 30g drop



The minimum deposit that can be made depends on several factors, the recipe, the mix, the template size, the nozzle size and deposit speed. As a guide the following is the minimum that should be attempted:

Macaroons	6g
Meringues	3g
Choux paste	5g
Sponge drops	4g

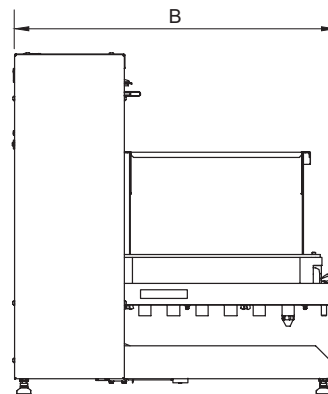
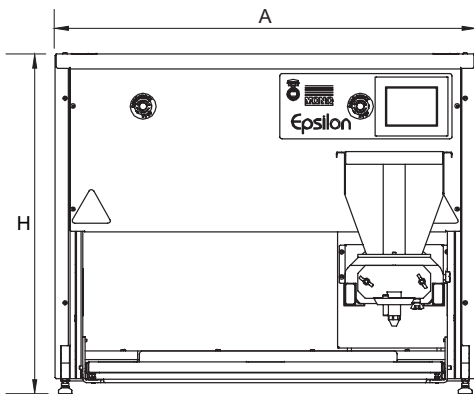

## Accessories

To complement the Epsilon Tabletop Confectionery Depositor, MONO Equipment also supplies a comprehensive range of accessories and ancillary items to suit every requirement.



Epsilon Table



Accessories Trolley



Mobile Tray Rack

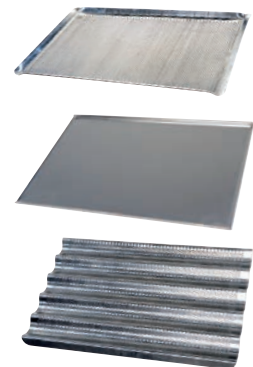

Selection of Trays

**INTERESTING FACT:**

**The History of Macarons**

Macarons are delicate almond cookies that are sandwiched together with a flavourful filling such as vanilla or chocolate ganache. They take their name from the Italian word, maccherone, meaning fine dough.

The first Macarons were simple cookies made of almond powder, sugar and egg whites. Many towns throughout France have their own prized tale surrounding this delicacy. In Saint-Jean-de-Luz, the macaron of Chef Adam was created for Louis XIV and Marie-Therese at their wedding celebration in 1660.

It is believed that the macaron was first produced in Italy during the 8th Century AD and was brought over to France in 1533 by Catherine de' Medici, a noblewoman from Florence, when she married Henry II of France.

In 1792, the macaron started to gain popularity when two Carmelite nuns arrived in Nancy seeking refuge during the French Revolution. They started to bake and sell macaron cookies to pay for their lodgings and the nuns became known as the 'macaron sisters'.

However, it wasn't until the 1930's that the macaron as we know it today, two almond meringue discs sandwiched together with buttercream, jam or ganache filling, was created.



MONO Equipment is one of the leading designers and manufacturers of bakery and foodservice equipment in the United Kingdom. This proud heritage of British craftsmanship, combined with a reputation for creating high-quality, innovative products, can be traced back to its origins in 1947.

MONO Equipment is the longest established confectionery depositor manufacturer in the world. This illustrious history boasts a longline of depositing machines from the original MKV, produced in the 1960's to the state of the art Omega and Epsilon machines available today which can produce an endless variety of cakes, confectionery and biscuits.

Our ground-breaking Epsilon Tabletop Confectionery Depositor is one of the smallest tabletop depositors available on the market today, requiring less than 1m<sup>2</sup> of space in which to operate.

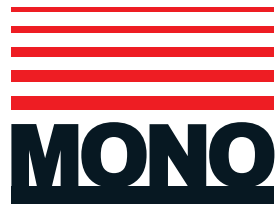

#### **MONO Equipment**

Queensway, Swansea West Industrial Park,  
Swansea SA5 4EB United Kingdom

Tel: +44 (0)1792 561 234 (Switchboard)

Tel: +44 (0)1792 564 000 (UK Sales)

Tel: +44 (0)1792 564 004 (International Sales)

Tel: +44 (0)1792 564 048 / +44 (0)1792 564 039 (Spares)

Fax: +44 (0)1792 561 016

Email: [sales@monoequip.com](mailto:sales@monoequip.com) Web: [www.monoequip.com](http://www.monoequip.com)



FM12346

EMS 595394

an Ali Group Company



The Spirit of Excellence