



www.monoequip.com

OVEN SERIAL NO. _____
In the event of an enquiry please quote this number.



COMPACT SERIES

434 4 TRAY OVEN
WITH MANUAL CONTROL

OPERATING AND MAINTENANCE MANUAL

FILE 111

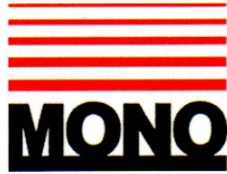

DECLARATION OF CONFORMITY

We hereby declare that this machine complies with the essential health and safety requirements of :-

- The Machinery Directive 2006 / 42 / EC
- The Low voltage Directive 2014 / 35/ EC
- The requirements of the Electromagnetic Compatibility Directive 2004 / 108EC, 91 / 263 / EEC, 92 / 31 / EEC
Incorporating standards
EN55014-1:2006+A1:2009+A2:2011
EN55014-2:1997+A1:2001+A2:2008
- The General Safety of Machinery and food processing Standards applicable
- Materials and Articles intended to come into contact with food
Regulation (EC) No. 1935 / 2004

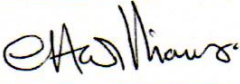
Signed			
G.A.Williams – Quality Manager			
Date			
Machine FG Code.		Machine Serial No.	

A technical construction file for this machine is retained at the following address:

MONO EQUIPMENT
Queensway,
Swansea West Industrial Park,
Swansea
SA5 4EB
UK

MONO EQUIPMENT is a business name of **AFE GROUP Ltd**
Registered in England No.3872673 VAT registration No.923428136

Registered office: Unit 9, Bryggen Road,
North Lynn Industrial Estate,
Kings Lynn,
Norfolk,
PE30 2HZ

SAFETY SYMBOLS

The following safety symbols are used throughout this product documentation. Before using your new equipment, read the instruction manual carefully and pay special attention to information marked with the following symbols.



WARNING

Indicates a hazardous situation which, if not avoided, will result in death or serious injury.



WARNING

Indicates a hazardous situation which, if not avoided, will result in electric shock.



CAUTION

Indicates a hazardous situation which, if not avoided, will result in minor or moderate injury.

ELECTRICAL SAFETY AND ADVICE REGARDING SUPPLEMENTARY ELECTRICAL PROTECTION:

Commercial bakeries, kitchens and food service areas are environments where electrical appliances may be located close to liquids, or operate in and around damp conditions, or where restricted movement for installation and service is evident.

The installation and periodic inspection of the appliance should only be undertaken by a qualified, skilled and competent electrician, and connected to the correct supply suitable for the load as stipulated by the appliance data label.

The electrical installation and connections should meet the necessary requirements of the local electrical wiring regulations and any electrical safety guidelines.

We Recommend:

- Supplementary electrical protection with the use of a residual current device (RCD)
- Fixed wiring appliances incorporate a locally situated switch disconnecter to connect to, which is easily accessible for switching off and safe isolation purposes. The switch disconnecter must meet the specification requirements of IEC 60947.

Your attention is drawn to:

BS 7671:2018 – Guidance Note 8 – 8.13 : Other locations of increased risk

It is recognised that there may be locations of increased risk of electrical shock other than those specifically addressed in Part 7 of BS 7671. Examples of such locations could include laundries where there are washing and drying machines in close proximity, and water is present, and commercial kitchens with stainless steel units, where once again, water is present. Where, because of the perception of additional risks being likely, the installation designer decides that an installation or location warrants further protective measures, the options available includes:

- Automatic Disconnection of Supply (ADS) by means of a residual current device having a residual operating current not exceeding 30 mA;
- Supplementary protective equipotential bonding; and
- Reduction of maximum fault clearance time.

The provision of RCDs and supplementary bonding must be specified by the host organisation's appointed installation designer or electrical contractor and installed by a suitably qualified and competent electrician so as to comply with Regulations 419.2 and 544.2.



The supply to this machine must be protected by a **30mA RCD**

CONTENTS

PART 1.0 **Introduction**

PART 2.0 **Dimensions**

PART 3.0 **Specifications**

PART 4.0 **Safety**

PART 5.0 **Installation**

PART 6.0 **Isolation**

PART 7.0 **Cleaning Instructions**

PART 8.0 **Operating Conditions**

PART 9.0 **Operation Instructions**

PART 10.0 **Maintenance**

PART 11.0 **Steam System Maintenance**

PART 12.0 **Spares Information**

1.0 INTRODUCTION

The MONO 434 COMPACT oven

is a compact, electric oven with a capacity for four 34cm x 45cm baking trays.

- The oven is robustly made of **stainless steel** with a bake chamber shaped to allow the unit to be **easily cleaned**.
- It has very high levels of **insulation for safety** and to **help save energy**.
- A great deal of attention has been given to keeping the **front areas cool**.
- **MONO 434 COMPACT** is designed to be **stackable**, without the requirement for a separate support and will grow with your business without occupying a large area of your valuable retailing space.

2.0 DIMENSIONS

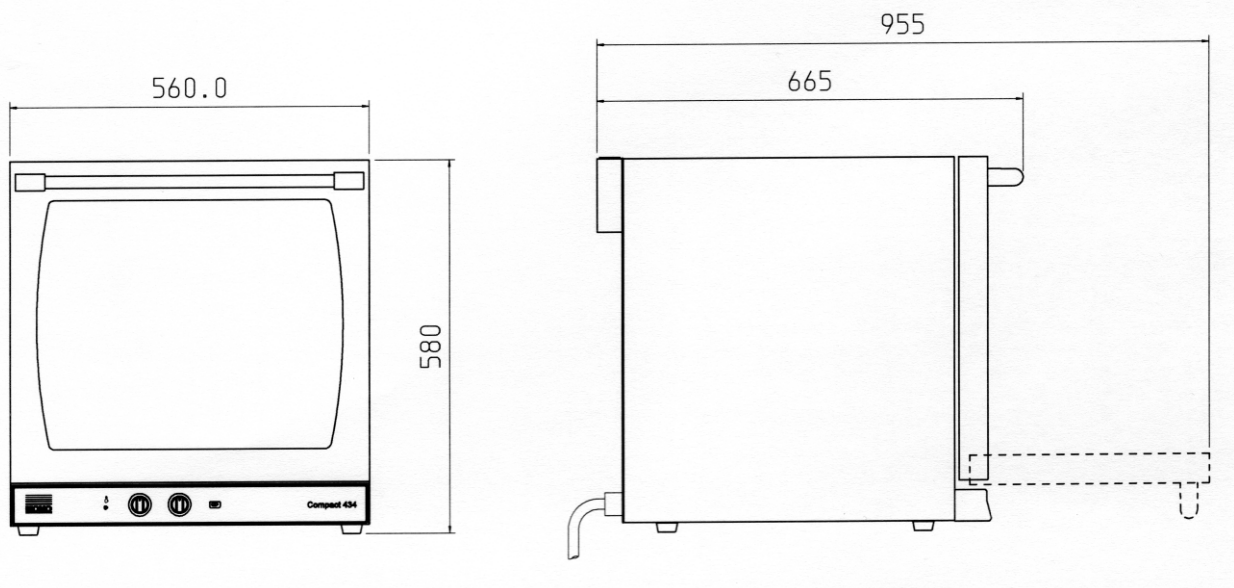

2.1 OUTER DIMENSIONS

Height: 580mm.

Depth, door closed: 665mm.
Depth, door open: 995mm.

Width: 560mm.

Operational clearance:

50mm (2") clearance is required at the back and sides of the oven and 250mm (10") above to allow adequate circulation of air.

3.0 SPECIFICATIONS

Total Power: 2.7 kW.

Electric Supply: 230V. Single-phase 50Hz , 13Amp



The supply to this machine must be protected by a **30mA RCD**

Supply Cable: 2 metres of cable supplied.

Water connection 3/4" B.S.P. and should be at a pressure of 2 bar to 4 bar.
(normal domestic water supply is usually within these limits).

Maximum bake temperature	260 degrees C
Maximum bake time	2 hours
Maximum steam time	20 seconds

Noise Level: Less than 85dB.

WEIGHT 34kg

4.0 SAFETY

In the interest of safety and efficient operation of this oven, it is essential that this manual should be made available to the operator before work is commenced. The following points should be closely observed and rigorously pursued at all times.

- To safely use this convection oven, read this owner manual completely and follow the warnings below, as well as all other warnings in this manual.
- The oven is designed for the baking of bread, confectionery and savory products. Do not use it for baking other items without first consulting the supplier.
- All repairs and maintenance of electrical units must only be carried out by an authorized service technician.



- Electrical access panels must not be opened except by an authorized service technician and the oven power cord must be unplugged.



- While the oven is in operation, and for some time after use, DO NOT TOUCH the oven window and surrounding area as these surfaces may be hot.

- The oven must be operated as described in this manual.
- Authorized service technicians should only use original manufacturer spare parts on the oven.
- The construction of the oven must not be changed or altered.



- This appliance must be disconnected from the power supply before moving or cleaning/servicing.

- Check for frayed or bare cables.
The machine must not be used if frayed or bare cables are visible.



- Oven gloves should be worn when moving products in or out of the oven.
- Unless trays/containers for the purpose of holding the oven products are supplied with the oven by the manufacturer, it is the responsibility of the customer to ensure that the nature and surface conditions of materials likely to come into contact with food shall be such that they cannot contaminate or spoil the food.

5.0 INSTALLATION



CAUTION Because of the weight, lifting the oven should not be attempted by one person.

- Ensure that the oven base is level or a level working height surface capable of supporting at least 100kg is used
- The **COMPACT oven** should be connected to a local means of isolation.



The supply to this machine must be protected by a **30mA RCD**

- Operational clearance of 50mm (2") is required at back and sides of oven and 250mm (10") top clearance to allow circulation of air.
- In the interests of hygiene, before using the oven for the first time, we strongly recommend that you wipe the inside of your oven and all accessories thoroughly with a clean cloth soaked in warm soapy water. Although the utmost care is taken during assembly and pre-delivery inspection, there is always a possibility of residue contaminating your first bake if this is not done.

DISPOSAL

Care should be taken when the machine comes to the end of its working life. all parts should be disposed of in the appropriate place, either by recycling or other means of disposal that complies with local regulations.

(in UK, "environmental protection act 1990" applies)

6.0 ISOLATION

To stop the oven in an emergency, unplug the lead or switch off at the wall isolator.

7.0 CLEANING INSTRUCTIONS



NOTE:

BEFORE CLEANING, ISOLATE OVEN FROM MAINS SUPPLY AND ALLOW TO COOL.



IMPORTANT

NEVER SPRAY THE OVEN WITH A HOSE OR HIGH PRESSURE WASHING DEVICE. TO AVOID ELECTROCUTION OR OVEN DAMAGE –NEVER ALLOW WATER, STEAM, CLEANING SOLUTION, OR OTHER LIQUIDS TO ENTER THE ELECTRICAL PANELS OR CONNECTIONS.

- The equipment is to be cleaned daily using a solution of mild detergent and hot water.
- After the oven has been allowed to cool, remove the tray racks by loosening the fixing knob at the front and moving the rack slightly forwards to disengage the back locators. Withdraw the racks and wipe over.



TRAY RACK REMOVAL

- Sweep any debris left in the chamber (after it has been allowed to cool) onto trays and remove. Wipe out the chamber with a damp cloth that has been soaked in a solution of mild detergent and hot water.
- Replace the tray racks
- Brush down and wipe outer oven front, back and sides.
- Wipe clean outer oven front, back and sides with a damp cloth that has been soaked in a solution of mild detergent and hot water (do not soak the lower control panel area with water).

8.0 OPERATING CONDITIONS



- **CAUTION** Because of the weight, lifting the oven should not be attempted by one person.
- Ensure that the oven base is level or a level working height surface capable of supporting at least 100kg is used
- For the most efficient operation, the oven should be used in ambient temperatures not exceeding 40°C (115°F). The life of components will be reduced and your warranty will be affected if run above 40°C.
- The ventilation of steam (extraction) from the oven should be sufficient to ensure water does not condense on or around the oven. Any water ingress could affect your warranty.
- It is the customers' sole responsibility to arrange for adequate ventilation and operational clearance at the back and sides of the oven to allow circulation of air. Refer to Outer dimensions 2.1.
*Any component malfunctioning during the guarantee period that is found to have been subjected to excessive humidity or ambient working temperatures above 40°C (115°F) will not be covered by the component manufactures guarantee, or **MONO**'s product warranty.*

9.0 OPERATING INSTRUCTIONS

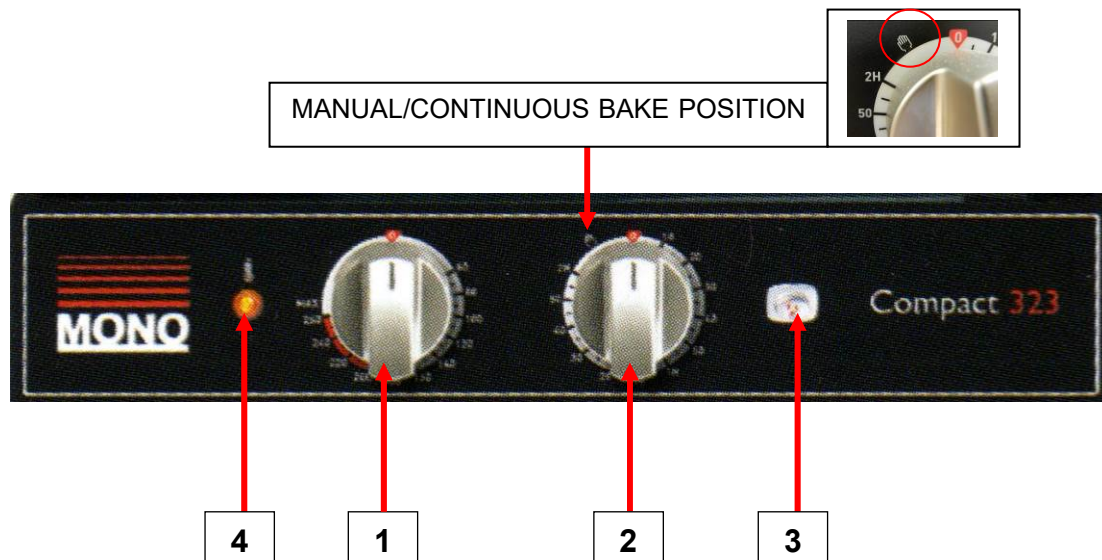

BAKING USING THE TIMER KNOB (2)

1. Turn temperature knob (1) to "0".
2. Connect power and water to the oven.
3. Preheat the oven before use.
Ensure the door is fully closed.
 - a. Turn the temperature knob (1) to a baking temperature about 30 degrees above the required backing temperature.
Pilot light will illuminate.
 - b. Turn the timer knob (2) to 10 minutes.
Pilot light will illuminate during heating and fan will start.
 - c. When pilot light goes out the oven is ready for use.
4. After preheating, insert the loaded trays and close the door.
(To preserve heat in the oven, do not keep the door open too long).
5. Check the temperature knob (1) is set to the required temperature you wish to bake at.
6. Set the timer knob (2) to the required bake time.
7. If steam is needed during the bake at any time, press the steam button (3) for the number of seconds of steam required.

MANUAL/CONTINUOUS SETTING

If required the oven can be set for manual/continuous baking by putting the timer knob (2) to the manual bake position and setting a temperature.
The oven can then be used as a standard oven with no timer required.
If steam is needed during the bake at any time, press the steam button (3) for the number of seconds of steam required.

10.0 MAINTENANCE



- Check for frayed or bare cables.
The oven must not be used if frayed or bare cables are visible.
- Follow cleaning instructions meticulously.
- There is no special maintenance required.

11.0 STEAM SYSTEM MAINTENANCE

If it is noticed that the steaming operation has deteriorated, perhaps due to hard water scaling, please contact your oven supplier.

12.0 Spares Information

Spares Tel. +44(0)1792 564039
email:spares@monoequip.com



Queensway
Swansea West Industrial Estate
Swansea.
SA5 4EB
UK

Tel. +44(0)1792 561234
Fax. 01792 561016

Web site:www.monoequip.com

Spares Tel. +44(0)1792 564039
email:spares@monoequip.com

□ DISPOSAL

CARE SHOULD BE TAKEN WHEN THE MACHINE COMES TO THE END OF ITS WORKING LIFE. ALL PARTS SHOULD BE DISPOSED OF IN THE APPROPRIATE PLACE, EITHER BY RECYCLING OR OTHER MEANS OF DISPOSAL THAT COMPLIES WITH LOCAL REGULATIONS.

(IN UK, ENVIRONMENTAL PROTECTION ACT 1990 APPLIES)