

www.monoequip.com

Enter **Serial No.** here. _____

In the event of an enquiry please quote this serial number.



OPERATION AND MAINTENANCE MANUAL

TABLE TOP DOUGHNUT FRYER





DECLARATION OF CONFORMITY

We hereby declare that this machine complies with the essential health and safety requirements of :-

- The Machinery Directive 2006 / 42 / EC
- The Low voltage Directive 2014 / 35/ EC
- The requirements of the Electromagnetic Compatibility Directive 2004 / 108EC, 91 / 263 / EEC, 92 / 31 / EEC
Incorporating standards
EN55014-1:2006+A1:2009+A2:2011
EN55014-2:1997+A1:2001+A2:2008
- The General Safety of Machinery and food processing Standards applicable
- Materials and Articles intended to come into contact with food Regulation (EC) No. 1935 / 2004

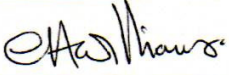
Signed	
G.A.Williams – Quality Manager	

Date	
-------------	--

Machine FG Code.		Machine Serial No.	
-----------------------------	--	-------------------------------	--

A technical construction file for this machine is retained at the following address:

MONO EQUIPMENT
Queensway,
Swansea West Industrial Park,
Swansea
SA5 4EB
UK

MONO EQUIPMENT is a business name of **AFE GROUP Ltd**
Registered in England No.3872673 VAT registration No.923428136

Registered office: Unit 9, Bryggen Road,
North Lynn Industrial Estate,
Kings Lynn,
Norfolk,
PE30 2HZ





Safety during emptying and cleaning of fryers

Catering Information Sheet No 17 (revised)

Introduction

Accidents during the emptying and cleaning of fryers are a major cause of the burns suffered by employees in the catering industry.

This information sheet gives guidance on how to empty and clean fryers safely.

Hazards

Hazards connected with emptying and cleaning fryers include:

- fire;
- burns from hot oil;
- contact with hot surfaces;
- fumes from boiling cleaning chemicals and the danger of the chemicals overflowing;
- eye injuries from splashes;
- slips from fat spillage; and
- strains and sprains while lifting and moving containers of oil.

When to empty and clean

Most catering establishments are closed overnight for a least eight hours. For fire safety and economy, fat fryers must be switched off when unattended. It is therefore common sense that cleaning and oil filtering should always be planned as a **first task of the day** rather than part of the closing down procedure.

If a 24 hour service is offered and the appliance is required continuously, there are two safe options:

- use more than one fryer and clean them in rotation; or
- use a fat saver or similarly designed appliance that removes the hot oil direct from the fryer, filters the oil and holds it safely. Under no other circumstances should personnel remove oil that is hot.

Oil draining

Rules for draining oil safely and in the correct sequence can be based on the following guidelines.

- Switch off appliance.
- Allow oil to cool, ideally for at least six hours, and before draining the oil, check the temperature using a suitable probe thermometer. Do not drain if this is above 40°C.
- If the oil is too cold to drain easily, reheat the oil briefly and agitate with the fryer basket (for no more than one minute). Switch the appliance off and check the temperature before emptying.
- Follow any instructions and use the equipment needed, eg a detachable spout for the type of fryer being emptied.
- Using a filter, run the oil into a suitable, clean, dry, metal holding container (plastic may melt) with carrying handles and a cover or lid. Depending on the type of fryer, draining of oil will be by drain valve, removable spout, lifting container or tilting.
- Place the full container in a safe place where it cannot be contaminated with chemicals, water or foreign bodies. Place the container on top of a drip tray to avoid any floor contamination. Use two people whenever possible if the container has to be moved and have any lid or cover secured before moving.
- Loss of special tools or proper containers is a common problem. Attaching these to the fryer can help prevent this. Do not dispose of waste oil down the drain. It can be sold for reclarification.
- Clean and dry floor afterwards to avoid slip risks.

Other precautions

- Ensure the design of the drain-off tap prevents it being turned on accidentally.
- Mark the tap clearly that it should not be touched.
- Place warning signs near the tap.

- If possible, remove the tap handle when the fryer is switched on.
- Never attempt to move or slide along a hot fryer.

Cleaning procedure

- Check that other activities will not be endangered by the cleaning activity.
- Check that the oil has been thoroughly drained and that there are no spillages that may cause slipping.
- Ensure that the power supply is switched off and the equipment isolated.
- Remove loose debris from the internal surfaces.
- Ensure suitable protective equipment is worn, including eye protection (if appropriate).
- Thoroughly wash all internal and external surfaces with suitable cleaning chemicals and check for any leaks.
- For stubborn residues, fill the fryer with your recommended cleaning agents and leave or boil according to instructions.
- Drain appliance and rinse thoroughly with copious amounts of water. Rinse all the areas of the fryer with hot water.
- Dry all internal surfaces and make sure there is no water left in the fryer.
- Check drain valve is closed and working properly, refill and switch on as required. Resist the temptation to overfill, especially on table top models. Check equipment is safe.

Training

- Only staff who have been trained in the safe use of the cleaning chemicals and the cleaning procedures for the fryer should be allowed to do this task.
- A short, written procedure can act as a reminder to staff for both draining and cleaning operations.

- Safety data sheets for cleaning chemicals should be available and staff made aware of these.

Further reading

Managing the health and safety of catering equipment and workplaces HSE Catering Information Sheet 8 HSE Books 1997

Planning for health and safety when selecting and using catering equipment and workplaces HSE Catering Information Sheet 9 HSE Books 1997

Maintenance priorities in catering HSE Catering Information Sheet 12 HSE Books 2000

Manual handling in the catering industry HSE Catering Information Sheet 13 HSE Books 2000

While every effort has been made to ensure the accuracy of the references listed in this publication, their future availability cannot be guaranteed.

Further information

HSE priced and free publications are available by mail order from HSE Books, PO Box 1999, Sudbury, Suffolk CO10 2WA. Tel: 01787 881165 Fax: 01787 313995. Website: www.hsebooks.co.uk

HSE priced publications are also available from good booksellers.

For other enquiries ring HSE's InfoLine Tel: 08701 545500, or write to HSE's Information Centre, Broad Lane, Sheffield S3 7HQ. Website: www.hse.gov.uk

This leaflet contains notes on good practice which are not compulsory but which you may find helpful in considering what you need to do.

This publication may be freely reproduced, except for advertising, endorsement or commercial purposes. The information is current at 2/01. Please acknowledge the source as HSE.

**THIS EQUIPMENT IS HEAVY AND SHOULD NOT BE LIFTED BY
ONE PERSON**

**Failure to adhere to the cleaning and
maintenance instructions detailed in this booklet
could affect the warranty of this machine.**

CONTENTS

Section - 1.0	Introduction
Section - 2.0	Dimensions
Section - 3.0	Specifications
Section - 4.0	Safety
Section - 5.0	Installation
Section - 6.0	Isolation
Section - 7.0	Cleaning Instructions
Section - 8.0	Operating instructions <ul style="list-style-type: none">▫ Float fry operation▫ Immersion fry operation
Section - 9.0	Service and spares
Section - 10.0	Electrics

1.0 INTRODUCTION

The table Top Fryer is designed for frying ball, ring and finger doughnuts. Features include:

- Thermostat controlled fat/oil temperature and a safety override thermostat.
- Quick drain mesh frying screens
- Easy lowering/raising of doughnuts into fat
- Drain tap
- Adjustable feet
- Special doughnut turning device for use when float frying
- The easily removed control box located on the side of the fryer has “Mains On” and “Heat on/off “indicator lights and a manually reset, thermostatically controlled, safety cut-out.

2.0 DIMENSIONS

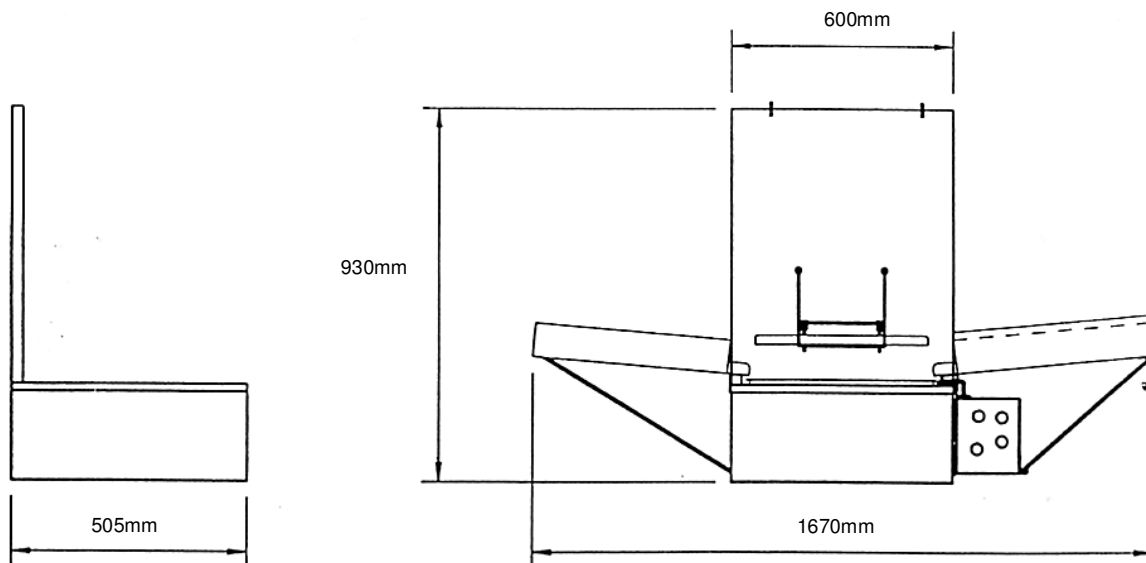

3.0 SPECIFICATIONS

Power:	240v. Single phase. 7.0kW fused at 32amp 415v. 3 phase + neutral 7.0kW fused at 16amp per phase
Safety Thermostat:	221 degrees C (430F) Trip switch reset manually after temperature drop.
Output:	up to 500 doughnuts per hour.
Fat/oil level:	50mm (2") below lip of frying tank. (allow for expansion when heating up from cold)
Weight:	94kg (207lb).
Noise level:	Less than 85dB.

This machine is clad entirely in stainless steel.

4.0 SAFETY

In the interests of safety and efficient operation of this fryer, it is essential that this manual should be made available to all personnel who may be required to operate it, before work is commenced.

The following points should be closely observed and rigorously pursued at all times

- 1 Never use the fryer in a faulty condition and always report any damage.
- 2 No-one under the age of 16 may operate this machine.
- 3 No-one under the age of 18 may clean this machine under any circumstances.
- 4 Only trained personnel may remove any part from this fryer that requires a tool to do so.
- 5 Always ensure hands are dry before touching any electrical appliance (including cable, switch and plug).
- 6 All operatives must be fully trained.
- 7 People undergoing training on the machine must be under direct supervision.
- 8 Do not operate the machine with any panels removed.
- 9 All guards must be fixed in place with bolts or screws unless protected by a safety switch.
- 10 No loose clothing or jewellery to be worn while operating the fryer.
- 11 Switch off power at the mains isolator when fryer is not in use and before carrying out any cleaning or maintenance.

ALL CLEANING AND MAINTENANCE OPERATIONS MUST BE MADE WITH FRYER DISCONNECTED FROM THE POWER SUPPLY

- 12 The Bakery Manager or the Bakery Supervisor must carry out daily safety checks on the fryer.

**WARNING
THIS EQUIPMENT IS HEAVY AND SHOULD NOT BE LIFTED BY ONE PERSON**

5.0 INSTALLATION

WARNING
THIS EQUIPMENT IS HEAVY AND SHOULD NOT BE LIFTED BY ONE PERSON

- 1 It is recommended that the Doughnut Fryer should be sited away from any main thoroughfare and that the surrounding floor area should be covered with a proprietary brand of non-slip surfacing.
- 2 Ventilation should be provided with an extraction canopy to ensure that convected heat and cooking smells are removed from the building. The canopy should extend a minimum of 300mm (12") beyond each edge of the fryer and have its lowest point between 1980mm (78") and 2740mm (108") above the floor. The extraction canopy should be fitted with a grease trap.
- 3 The table or bench the fryer is to be used on should be strong enough to give support when full of oil and capable of taking an accidental blow during operation.
4. Check that the power supply matches the rating plate fixed to the control box.
5. To ensure that the machine is safe to use, If a base unit is supplied with the fryer it must be attached to the fryer by a "MONO" engineer.

6.0 ISOLATION

**To stop the Doughnut Fryer in an emergency
switch off at the mains wall isolator.**

7.0 CLEANING INSTRUCTIONS

WARNING:

HOT OIL IS DANGEROUS. ALLOW OIL TO COOL BEFORE ATTEMPTING TO DRAIN OR CLEAN ANY PART OF FRYER.

ISOLATE FRYER FROM MAINS SUPPLY BEFORE CLEANING

□ **GENERAL CLEANING**

- 1 Wipe down exterior brightwork with a damp cloth.
- 2 To help cleaning, While fat is still liquid (NOT HOT), heating unit may be lifted out of oil tank.

□ **DRAINING COOKING OIL / MOLTEN FAT**

- 1 Allow oil to cool and place container under drain spout and open valve.
Drain out contents of frying tank.
Do not leave the tank draining and walk away, the tank will hold more than the container, which will need to be changed at regular intervals. Use the tap to turn off the oil flow between each container change.
- 2 Close drain valve before removing container

8.0 OPERATING INSTRUCTIONS

NOTE

SHOULD THE OIL TEMPERATURE EXCEED SAFE LIMITS (LOW OIL LEVEL ETC), THE SAFETY THERMOSTAT WILL OPERATE.

TO RESET, ALLOW OIL TO COOL (TEMPERATURE MUST DROP) AND PRESS RED BUTTON SET INSIDE A SMALL HOLE IN THE CONTROL BOX SIDE SHEET.

Doughnuts should be proofed on the frying screens to the required size and placed in the fryer without being touched. If moved on to the frying screens after proofing they will collapse and an inferior product will be the result.

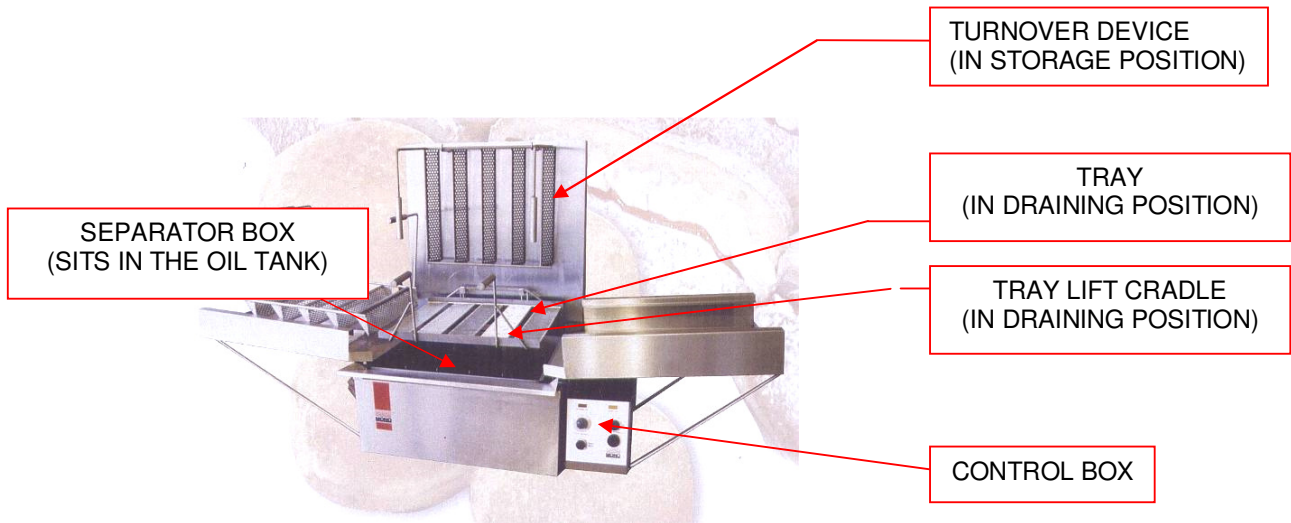
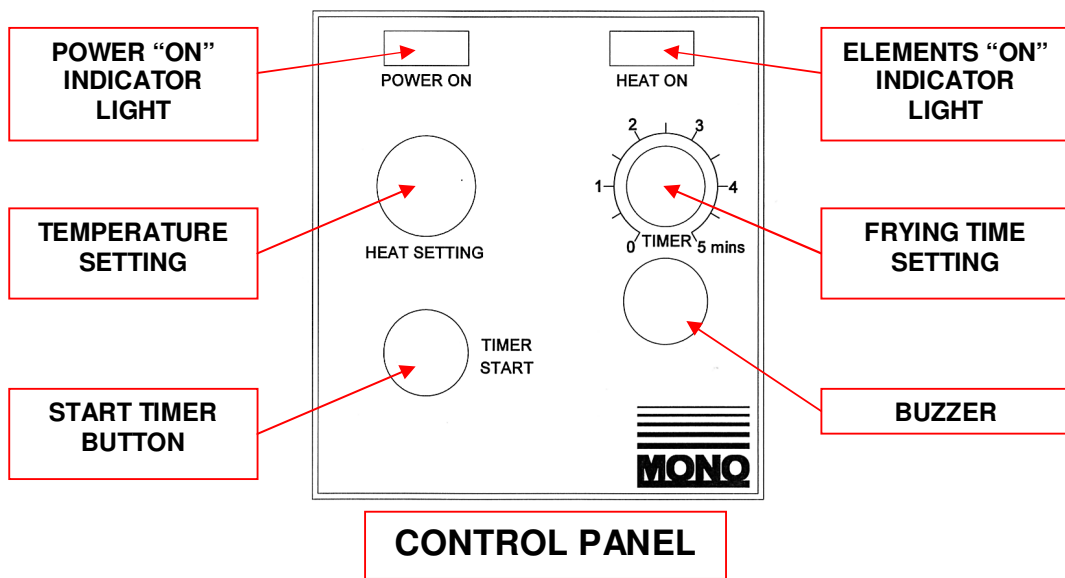

FLOAT FRY OPERATION

□ **BEFORE USE**

- 1 Attach draining boards, control box and separator box. Hang turnover device on hooks at top of back sheeting and tray cradle on lower hooks.
- 2 Check that drain tap is closed.
- 3 Fill the fryer with suitable cooking oil to just below 2" (50mm) from the top. (Correct operational level of the oil is 2" from the top, but allowance should be made for expansion of the oil when heated.)

IF SOLID FAT IS TO BE USED – break up fat and melt gradually by turning the elements on and off for 15 second periods until the elements are totally submerged. This will stop any damage to the elements.

□ **OPERATION**

- 1 Set frying temperature required on thermostat and ensure that both indicator lights are on.
- 2 When the heat on light goes out, the oil is at the correct temperature for cooking.
- 3 Slide a tray of doughnuts on to the cradle.
- 4 Set timer to fry time required.
- 5 Unhook cradle and gently lower into the oil.
- 6 Press the timer button.
- 7 When timer sounds and the doughnuts are cooked on one side, the turnover device should be lowered into the tank ensuring that the device is held against the baffles of the separator unit making the doughnuts turnover. (Leave the device in the oil).
- 8 Press the timer button again.
- 9 When the timer sounds, remove the turnover device and hang it back on the back sheet top hooks.
- 10 Remove the cradle and hang back on the lower rear hooks to allow the doughnuts to drain.
- 11 Slide tray on to drainer to drain for more time and slide a fresh tray on to cradle and repeat the procedure.

IMMERSION FRY OPERATION (PARTS OPTIONAL)

□ **BEFORE USE**

- 1 Attach draining boards, control box but not separator box. Place element guard (spider) in the bottom of the tank. Hang immersion cradle on lower hooks.
- 2 Check that drain tap is closed.
- 3 Fill the fryer with suitable cooking oil to just below 2" (50mm) from the top. (Correct operational level of the oil is 2" from the top, but allowance should be made for expansion of the oil when heated.)

IF SOLID FAT IS TO BE USED – break up fat and melt gradually by turning the elements on and off for 15 second periods until the elements are totally submerged. This will stop any damage to the elements.

□ **OPERATION**

- 1 Set frying temperature required on thermostat and ensure that both indicator lights are on.
- 2 When the heat on light goes out the oil is at the correct temperature for cooking.
- 3 Slide a tray of doughnuts into the cradle.
- 4 Set timer to fry time required.
- 5 Unhook cradle and gently lower into the oil.
- 6 Press the timer button.
- 7 When timer sounds and the doughnuts are cooked, remove the cradle and hang back on the lower rear hooks to allow the doughnuts to drain.
- 8 Slide tray on to drainer to drain for more time and slide a fresh tray on to cradle and repeat the procedure.

9.0 SERVICE AND SPARES

NOTE

SHOULD THE OIL TEMPERATURE EXCEED SAFE LIMITS (LOW OIL LEVEL ETC), THE SAFETY THERMOSTAT WILL OPERATE.

TO RESET, ALLOW OIL TO COOL (TEMPERATURE MUST DROP) AND PRESS RED BUTTON SET INSIDE A SMALL HOLE IN THE CONTROL BOX SIDE SHEET.

If a fault arises, please do not hesitate to contact Customer Service Department.

Tel. +44(0)1792 561234

email:spares@monoequip.com

Spares Tel.+44(0)1792 564039
Fax. 01792 561016



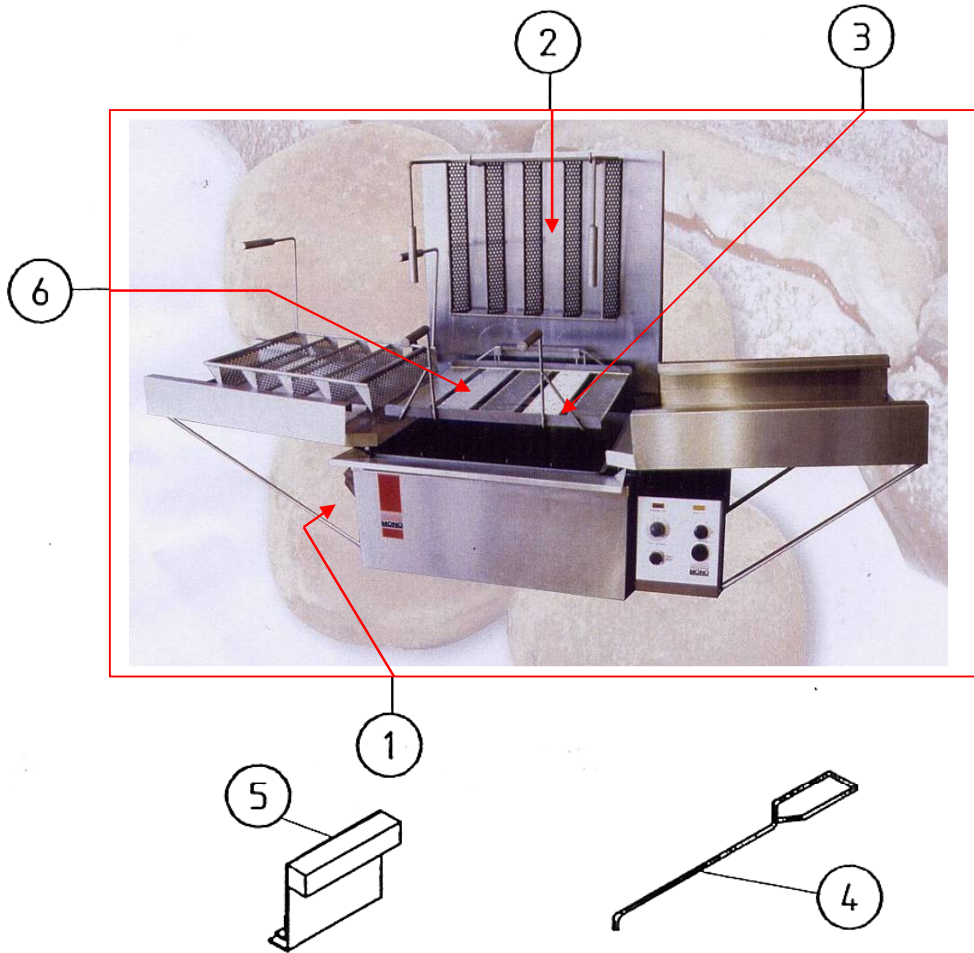

<u>Item</u>	<u>Description</u>	<u>Part No.</u>
1	TAP	A900-34-071
2	TURNOVER DEVICE	030-06-00000
3	TRAY LIFT CRADLE	030-07-00000
4	HOOK	030-08-00500
5	HANDLE	030-08-00600
6	SCREENS	030-08-00100

FOR ELECTRICAL SPARES SEE ELECTRICAL COMPONENT SECTION



10.0 ELECTRICS

IF IN ANY DOUBT - ASK

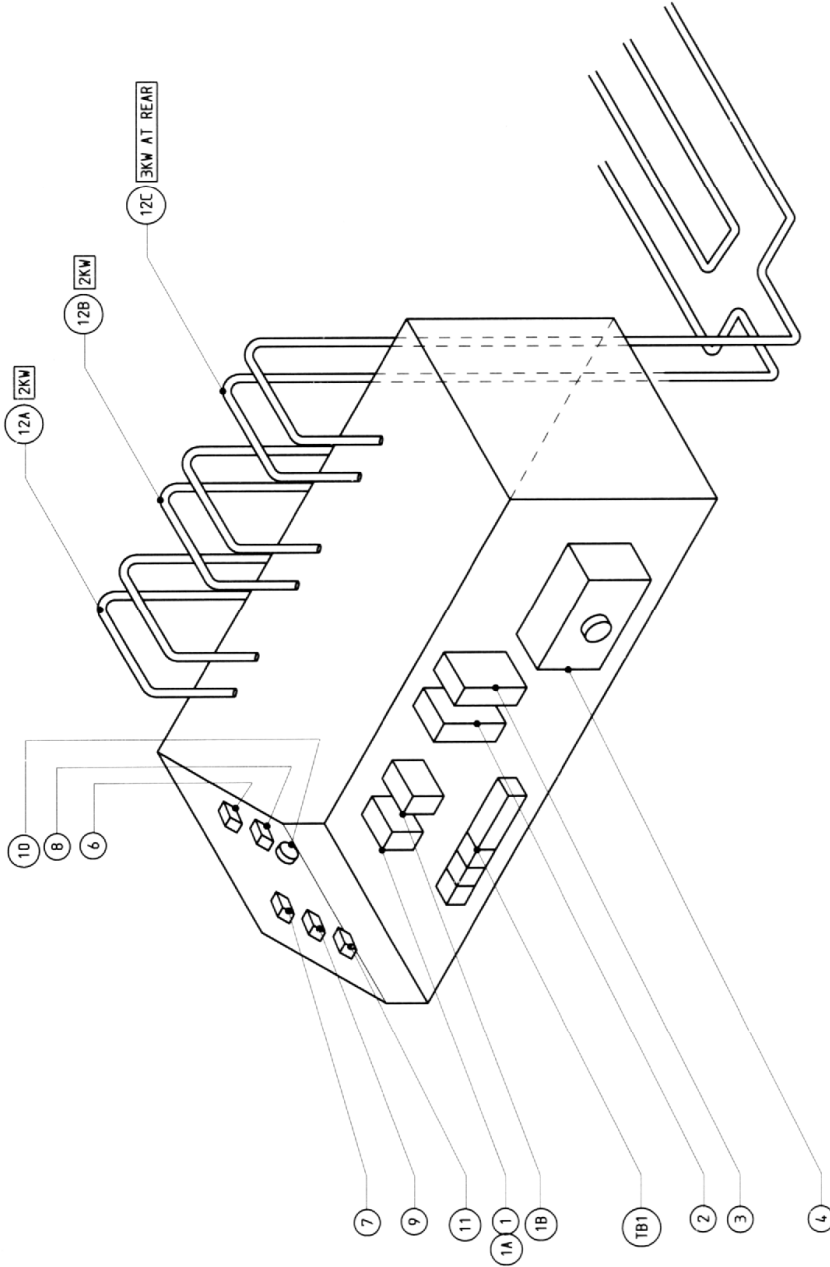

PARTS LIST

FOR 240v. 1PHASE - SEE SHEET 3
 FOR 415v. 3PHASE AND NEUTRAL - SEE SHEET 6

A	RAC	11-6-07	TIMER NOT AVAILABLE. PARTS REPLACED	REVISION	3004
REV	SIG	DATE	TITLE:		ECN NO.
			MONO EQUIPMENT QUEENSWAY SWANSEA WEST IND PARK SWANSEA. SA5 4EB. TEL: (01782) 561234 FAX: (01782) 561016	COMPONENT LAYOUT	
ELECTRICAL SPECIFICATIONS:-			DRAWN:	ELECTRICALLY APPROVED BY:-	
			RAC		
			DATE:	DRAWING NO.	REV.
			5-12-92	M030-25-00000	A
			11-6-07	SHEET 2	

COPYRIGHT © 1998 - THIS DESIGN/DRAWING IS THE PROPERTY OF MONO EQUIPMENT LTD. AND MUST NOT BE REPRODUCED, COPIED, NOR ITS CONTENTS DIVULGED WITHOUT PRIOR WRITTEN PERMISSION.

IF IN ANY DOUBT - ASK

DRAWING PART No.	DESCRIPTION	PART No.	QTY
1	MAIN TIMER	B819-34-004	1
1A	11 PIN BASE	B822-36-002	1
1B	SOUNDER ON TIMER	B842-34-003	1
2	CONTROL MCB	B872-22-001	1
3	HEATER CONTACTOR	B801-08-007	1
4	OVERHEAT THERMOSTAT	B888-30-002	1
5	KILLER THERMOSTAT	B873-30-005	1
6	SUPPLY "ON" LIGHT	B842-43-005	1
7	HEAT "ON" LIGHT	B842-43-006	1
8	CONTROL THERMOSTAT	B873-30-013	1
9A	TIME SETTING POTENTIOMETER	B842-59-007	1
9B	TIME SETTING KNOB	B842-47-006	1
10A	START TIMER - PUSH BUTTON	B801-12-021	1
10B	START TIMER - CONTACT BLOCK	B801-14-002	1
11	AUDIBLE WARNING DEVICE	B704-92-001	1
12A	HEATING ELEMENT - 2KW	B847-04-028	1
12B	HEATING ELEMENT - 2KW	B847-04-028	1
12C	HEATING ELEMENT - 3KW	B847-04-029	1
	DIN RAIL C 100mm LONG	B852-26-009	0.055M
	TERMINAL BLOCKS	B852-50-022	4
	END PLATE	B852-40-016	1
	SHORTING LINKS	B852-13-019	2
	TERMINAL MARKER	B852-88-011	1
	TERMINAL MARKER	B852-88-012	1
	TERMINAL MARKER	B852-88-013	1
	TERMINAL MARKER	B852-88-014	1
	CABEL GLAND	B839-17-004	1
	MAINS CABLE	B884-72-001	3M
	LOCKNUT	B886-28-002	1
	SLEEVING - EXPANDIBLE	B842-87-003	1M
	CABLE - RED 1.5mm	B843-52-029	1.5M
	CABLE - BLUE 1.5mm	B843-52-025	1.5M
	CABLE - GREEN/YELLOW 1.5mm	B843-52-026	1M
	CABLE - RED 1.0mm	B843-52-001	1.5M
	CABLE - WHITE 1.0mm	B843-52-005	1.5M
	CABLE - BLUE 1.0mm	B843-52-002	1.5M

COPYRIGHT © 1998 - THIS DESIGN/DRAWING IS THE PROPERTY OF MOND EQUIPMENT LTD. AND MUST NOT BE REPRODUCED. COPIED.
 NOR ITS CONTENTS DIVULGED WITHOUT PRIOR WRITTEN PERMISSION.

REV	SIG	DATE	REVISION	ECN NO.
A	RAC	12/16/07	TIMER NOT AVAILABLE. PARTS REPLACED	3004
 MOND EQUIPMENT QUEENSWAY SWANSEA WEST IND PARK SWANSEA, SA6 4EB. TEL: (01792) 961234 FAX: (01792) 961016		TITLE: PARTS LIST		
ELECTRICAL SPECIFICATIONS:-		DRAWN: RAC		
24.0V. 50HZ 1 PHASE		ELECTRICALLY APPROVED BY:-		
DATE: 5/12/92		DRAWING NO. M030-25-00000 SHEET 3		
12/16/07		REV: A		



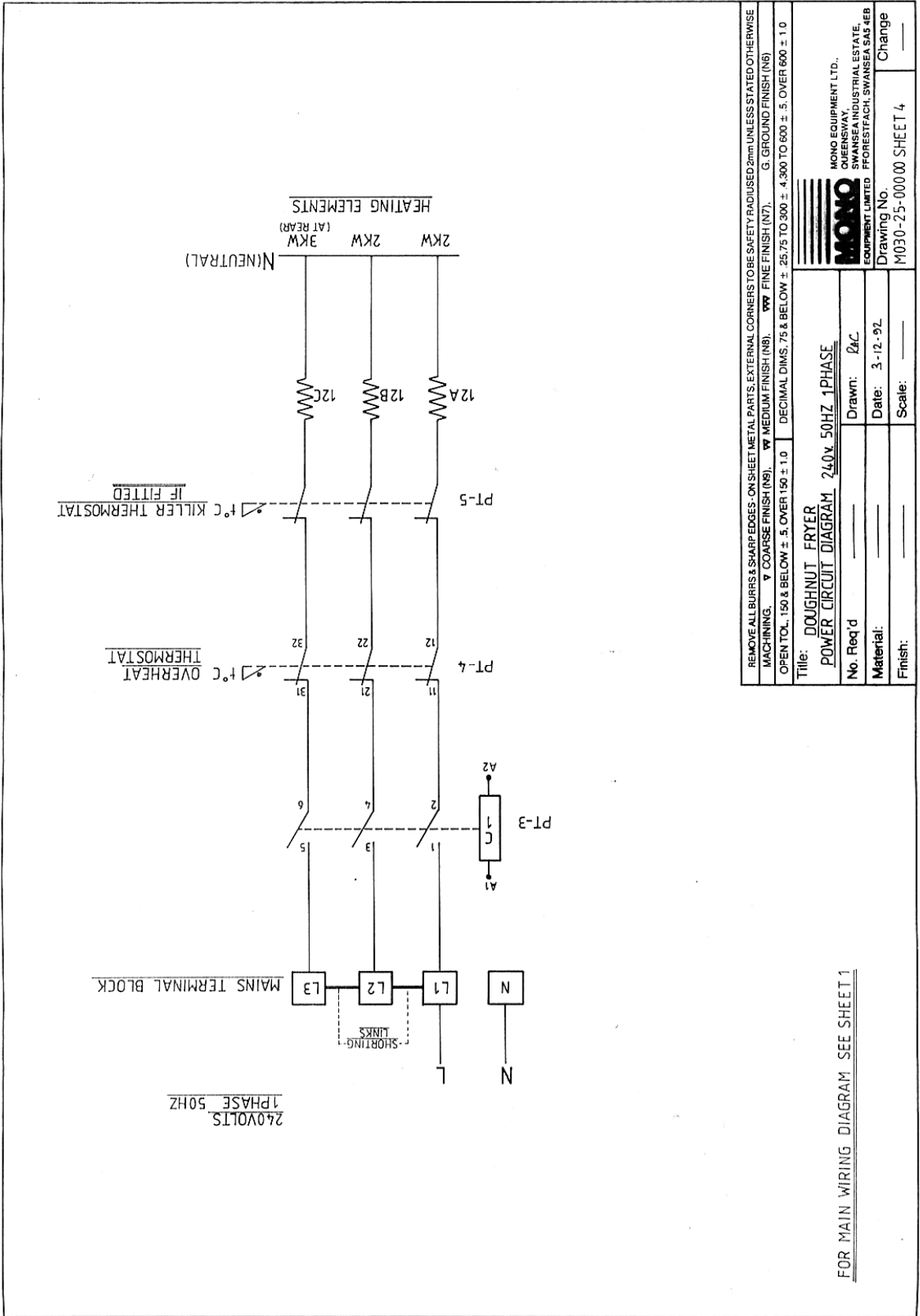

REMOVE ALL BURRS & SHARPEDES. ON SHEET METAL PARTS. EXTERNAL CORNERS TO BE SAFETY RADIUS 2mm UNLESS STATED OTHERWISE.	
MACHINING. ▽ COARSE FINISH (NS). ▽ MEDIUM FINISH (NB). ▽ FINE FINISH (NT). ▽ G. GROUND FINISH (NG)	
OPEN TOL. 150 & BELOW ± .5. OVER 150 ± 1.0	DECIMAL DIMS. 75 & BELOW ± .25. 75 TO 300 ± .4. 300 TO 600 ± .5. OVER 600 ± 1.0
Title: DOUGHNUT FRYER POWER CIRCUIT DIAGRAM 240V 50HZ 1PHASE	
No. Req'd	Drawn: BJC
Material:	Date: 3-12-92
Finish:	Scale:
Drawing No. M030-25-0000 SHEET 4	
Change	

FOR MAIN WIRING DIAGRAM SEE SHEET 1



IF IN ANY DOUBT - ASK

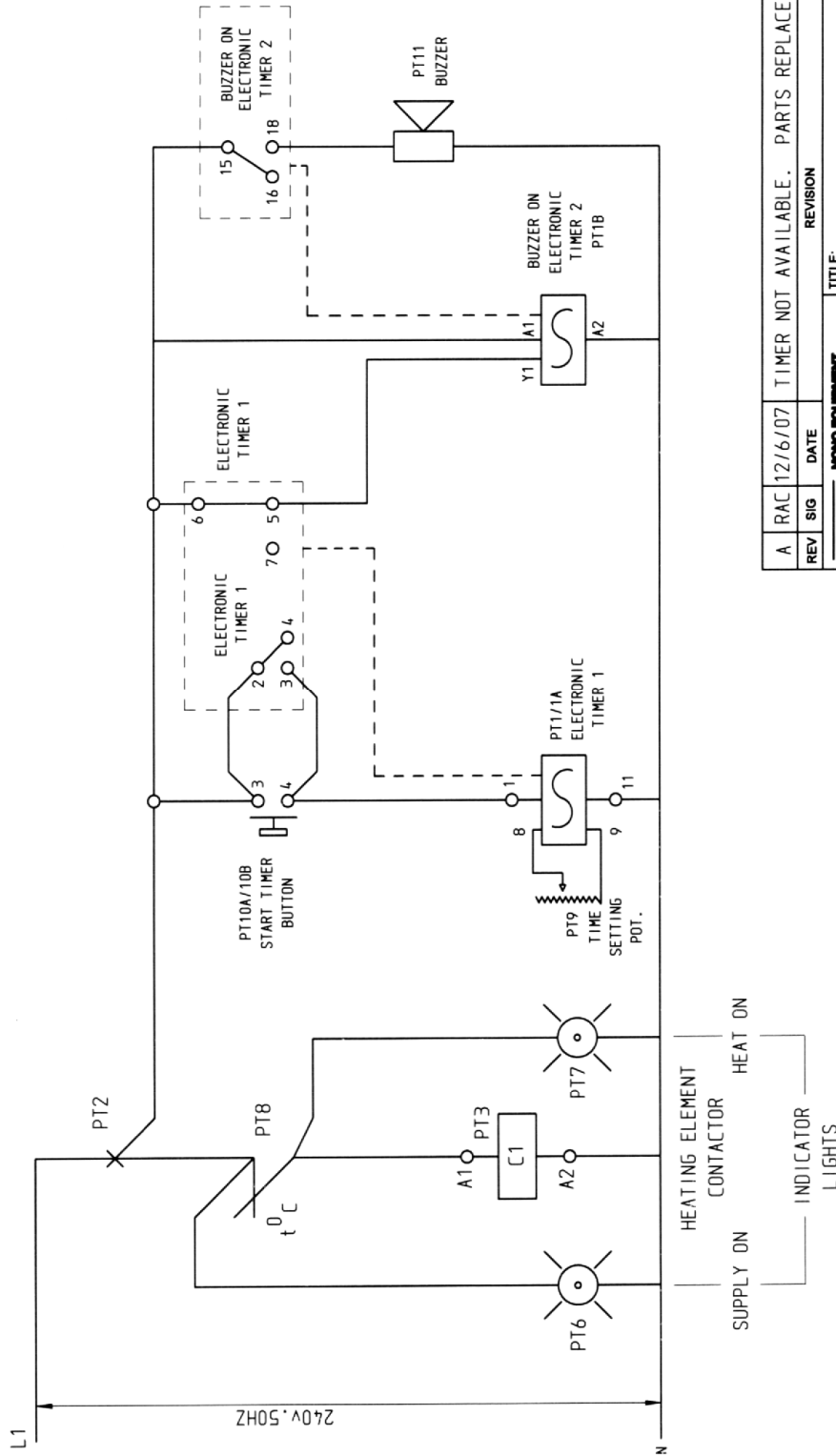

FOR MAIN PRODUCTION WIRING DIAGRAM SEE SHEET 1

REV	SIG	DATE	REVISION	ECN NO.
A		12/16/07	TIMER NOT AVAILABLE. PARTS REPLACED	3004
<p>MONO EQUIPMENT QUEENSWAY SWANSEA WEST IND PARK SWANSEA, SA5 4EB. TEL: (01782) 561234 FAX: (01782) 561016</p>				
<p>MONO</p>				
<p>ELECTRICAL SPECIFICATIONS:-</p>				
<p>TITLE: CONTROL CIRCUIT DIAGRAM</p>				
<p>DONUT FRYER</p>				
<p>DRAWN: RAC ELECTRICALLY APPROVED BY:-</p>				
<p>DATE: 3-12-92 11-6-07</p>				
<p>DRAWING NO. M030-25-00000 SHEET 5</p>				
<p>REV: A</p>				

COPYRIGHT © 1998 - THIS DESIGN/DRAWING IS THE PROPERTY OF MONO EQUIPMENT LTD. AND MUST NOT BE REPRODUCED, COPIED, NOR ITS CONTENTS DIVULGED WITHOUT PRIOR WRITTEN PERMISSION.



IF IN ANY DOUBT - ASK

DRAWING PART No.	DESCRIPTION	PART No.	QTY
1	MAIN TIMER	B819-34-004	1
1A	11 PIN BASE	B822-36-002	1
1B	SOUNDER ON TIMER	B842-34-003	1
2	CONTROL MCB	B872-22-001	1
3	HEATER CONTACTOR	B801-08-007	1
4	OVERHEAT THERMOSTAT	B888-30-002	1
5	KILLER THERMOSTAT	B873-30-005	1
6	SUPPLY "ON" LIGHT	B842-43-005	1
7	HEAT "ON" LIGHT	B842-43-006	1
8	CONTROL THERMOSTAT	B873-30-013	1
9A	TIME SETTING POTENTIOMETER	B842-59-007	1
9B	TIME SETTING KNOB	B842-47-006	1
10A	START TIMER - PUSH BUTTON	B801-12-021	1
10B	START TIMER - CONTACT BLOCK	B801-14-002	1
11	AUDIBLE WARNING DEVICE	B704-92-001	1
12A	HEATING ELEMENT - 2KW	B847-04-028	1
12B	HEATING ELEMENT - 2KW	B847-04-028	1
12C	HEATING ELEMENT - 3KW	B847-04-029	1
	DIN RAIL C 100mm LONG	B852-26-009	0.055M
	TERMINAL BLOCKS	B852-50-022	4
	END PLATE	B852-40-016	1
	TERMINAL MARKER	B852-88-011	1
	TERMINAL MARKER	B852-88-012	1
	TERMINAL MARKER	B852-88-013	1
	TERMINAL MARKER	B852-88-014	1
	CABEL GLAND	B839-17-001	1
	MAINS CABLE	B843-57-002	3M
	LOCKNUT	B886-28-002	1
	SLEEVING - EXPANDIBLE	B842-87-003	1M
	CABLE - RED 1.5mm	B843-52-029	1.5M
	CABLE - BLUE 1.5mm	B843-52-025	1.5M
	CABLE - GREEN/YELLOW 1.5mm	B843-52-026	1M
	CABLE - RED 1.0mm	B843-52-001	1.5M
	CABLE - WHITE 1.0mm	B843-52-005	1.5M
	CABLE - BLUE 1.0mm	B843-52-002	1.5M

REV	A	RAC	12/6/07	TIMER NOT AVAILABLE. PARTS REPLACED	3004
SIG		DATE		REVISION	ECH NO.
 MONO EQUIPMENT QUEENSWAY SWANSEA WEST IND PARK SWANSEA, SA5 4EB. TEL: (01792) 561234 FAX: (01792) 561016					
ELECTRICAL SPECIFICATIONS:-					
DRAWN: RAC					
DATE: 5/12/92					
12/4/07					
TITLE: PARTS LIST					
ELECTRICALLY APPROVED BY:-					
3 PHASE AND NEUTRAL					
DRAWING NO. M030-25-00000 SHEET 6					
REV: A					

COPYRIGHT © 1998 - THIS DESIGN/DRAWING IS THE PROPERTY OF MONO EQUIPMENT LTD. AND MUST NOT BE REPRODUCED. COPIED. NOR ITS CONTENTS DIVULGED WITHOUT PRIOR WRITTEN PERMISSION.



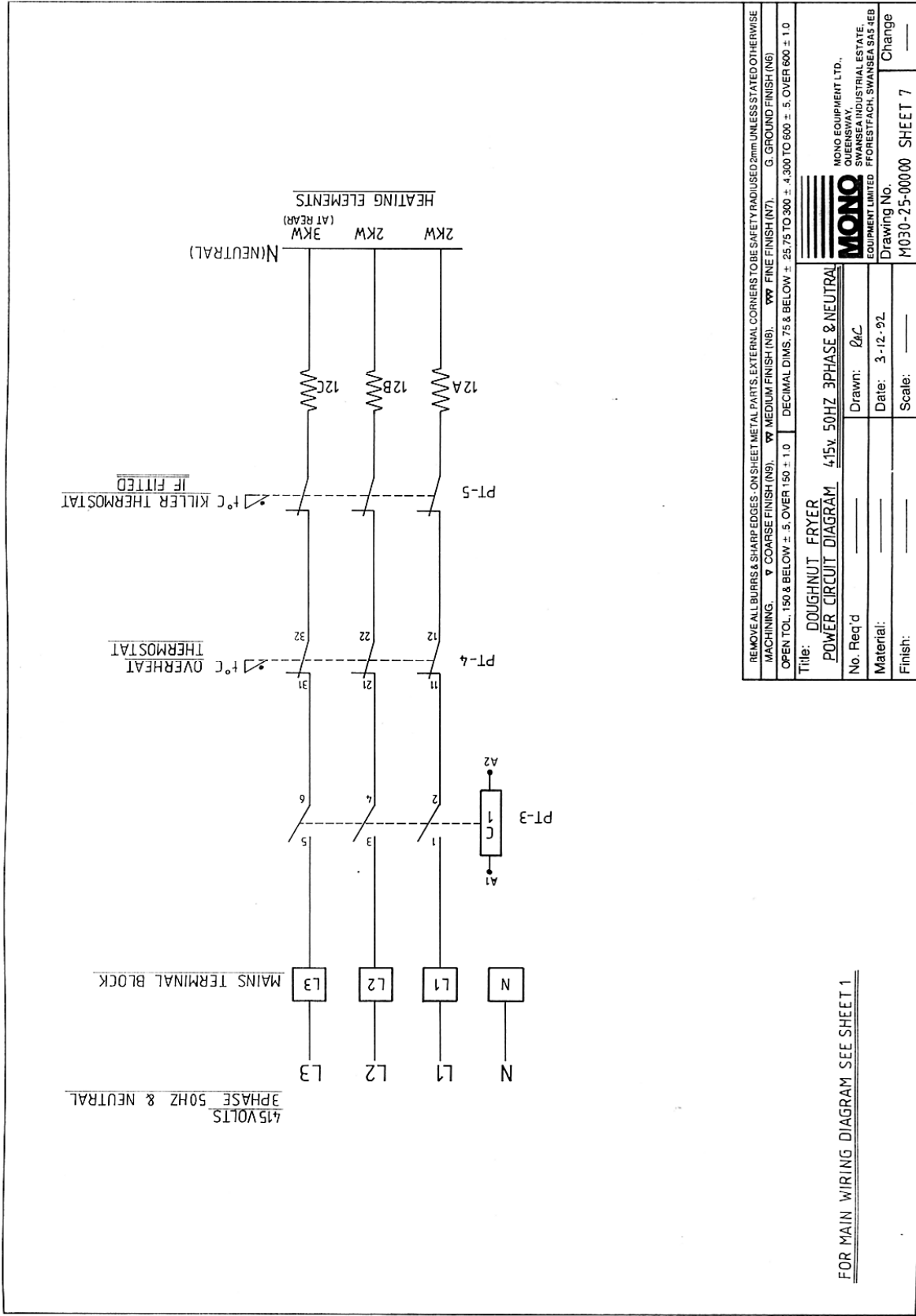

REMOVE ALL BURRS & SHARP EDGES. ON SHEET METAL PARTS. EXTERNAL CORNERS TO BE SAFETY RADIUS 2mm UNLESS STATED OTHERWISE

MACHINING: ▽ COARSE FINISH (N6) ▽ MEDIUM FINISH (N6) ▽ FINE FINISH (N7) G. GROUND FINISH (N6)

OPEN TOL. 150 & BELOW ± .5. OVER 150 ± 1.0 DECIMAL DIMS. 75 & BELOW ± .25. 75 TO 300 ± .4. 300 TO 600 ± .5. OVER 600 ± 1.0

Title: DOUGHNUT FRYER
POWER CIRCUIT DIAGRAM 415v 50HZ 3PHASE & NEUTRAL

No. Rec'd: _____ Drawn: JAC

Material: _____ Date: 3-12-92

Finish: _____ Scale: _____

Change No. _____

M030-25-00000 SHEET 7

MONO EQUIPMENT LTD.,
QUEENSWAY,
SWANSEA INDUSTRIAL ESTATE,
EQUIPMENT LIMITED, FOREST PACH, SWANSEA S45 7EB

FOR MAIN WIRING DIAGRAM SEE SHEET 1





MONO Equipment

Queensway, Swansea West Industrial Park, Swansea, SA5 4EB UK
Tel. 01792 561234 Fax. 01792 561016
Email:mono@monoequip.com

www.monoequip.com

As it is our policy to improve our machines continuously, we reserve the right to change specifications without prior notice.

- **DISPOSAL**

Care should be taken when the machine comes to the end of its working life. All parts should be disposed of in the appropriate place, either recycling or other means as the law permits at the time.