



[www.monoequip.com](http://www.monoequip.com)

Enter **Serial No.** here. \_\_\_\_\_

In the event of an enquiry please quote this serial number.



**OPERATING AND MAINTENANCE MANUAL  
TWIN SHEETING ROLLER MODEL  
MONO MULTI MOULDER**

**FILE 116**

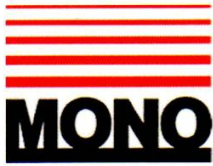

## DECLARATION OF CONFORMITY

We hereby declare that this machine complies with the essential health and safety requirements of :-

- The Machinery Directive 2006 / 42 / EC
- The Low voltage Directive 2014 / 35/ EC
- The requirements of the Electromagnetic Compatibility Directive 2004 / 108EC, 91 / 263 / EEC, 92 / 31 / EEC  
Incorporating standards  
EN55014-1:2006+A1:2009+A2:2011  
EN55014-2:1997+A1:2001+A2:2008
- The General Safety of Machinery and food processing Standards applicable
- Materials and Articles intended to come into contact with food Regulation (EC) No. 1935 / 2004

<b>Signed</b>	
G.A. Williams – Quality Manager	

<b>Date</b>	
-------------	--

<b>Machine FG Code.</b>		<b>Machine Serial No.</b>	
-----------------------------	--	-------------------------------	--

A technical construction file for this machine is retained at the following address:

**MONO EQUIPMENT**  
Queensway,  
Swansea West Industrial Park,  
Swansea  
SA5 4EB  
UK

**MONO EQUIPMENT** is a business name of **A FE GROUP Ltd**  
Registered in England No.3872673 VAT registration No.923428136

Registered office: Unit 9, Bryggen Road,  
North Lynn Industrial Estate,  
Kings Lynn,  
Norfolk,  
PE30 2HZ

# INDEX

---

- 1.0 Introduction**
- 2.0 Dimensions**
- 3.0 Specifications**
- 4.0 Safety**
- 5.0 Installation**
- 6.0 Isolation**
- 7.0 Cleaning Instructions**
- 8.0 Operating conditions**
- 9.0 General remarks – machine moulding of dough**
- 10.0 OPERATING INSTRUCTIONS**
  - Primary adjustments
  - Sheeting gap
  - Moulding pressure
  - Starting
- 11.0 Maintenance**
  - Moulding belt adjustment
  - Drive belt adjustment
- 12.0 MOULDER WILL NOT START**
- 13.0 Service**
- 14.0 Spares**
- 15.0 Electrical diagrams**

# 1.0 INTRODUCTION

---

The Multi Moulder will process up to 1200 dough pieces an hour, but will still treat your dough gently, giving a tight mould with no tails.

This versatile moulder will shape all oven bottom and tin bread to a standard that will please the most fastidious baker, and is easily adjustable for sheeting pressure, moulding width and moulding pressure.



## 2.0 DIMENSIONS

---

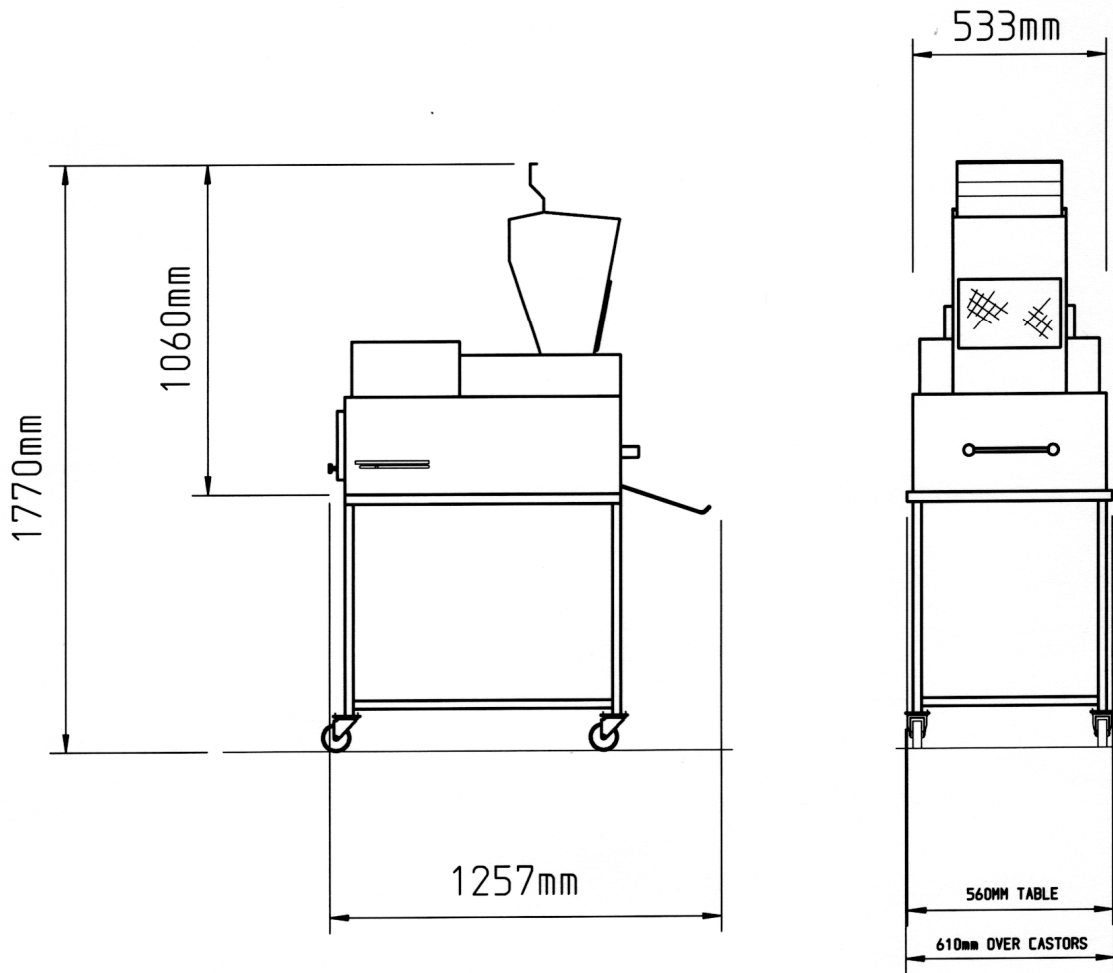

**Height:** 1770mm

**Width:** 560mm (610mm over castors)

**Length:** 1257mm

## 3.0 SPECIFICATIONS

---

**Electric:** 380v / 415v ,3 phase ,neutral,50/60Hz  
1.7 Amps per phase , 0.55kW.

**Weight:** 168kg.

**Noise Level:** Less Than 85 dB.

**Output:** up to 1200 dough pieces an hour

## 4.0 SAFETY

---

**ALL CLEANING AND MAINTENANCE OPERATIONS MUST BE MADE WITH MACHINE DISCONNECTED FROM THE POWER SUPPLY**

- 1 Never use a machine in a faulty condition and always report any damage.
- 2 No-one under the age of 16 may operate this machine.
- 3 No-one under the age of 18 may clean this machine under any circumstances.
- 4 Only trained personnel may remove any part from this machine that requires a tool to do so.
- 5 Always ensure hands are dry before touching any electrical appliance (including cable, switch and plug).
- 6 All operatives must be fully trained.
- 7 People undergoing training on the machine must be under direct supervision.
- 8 Do not operate the machine with any panels removed.
- 9 All guards must be fixed in place with bolts or screws unless protected by a safety switch.
- 10 No loose clothing or jewellery to be worn while operating the machine.
- 11 Switch off power at the mains isolator when machine is not in use and before carrying out any cleaning or maintenance.
- 12 The Bakery Manager or the Bakery Supervisor must carry out daily safety checks on the machine
- 13 If fitted, the power socket on the side must only be used for weighing scales.  
**DO NOT PLUG IN ANYTHING ELSE LIKE VACUUM CLEANERS.**  
The socket will trip and have to be reset by a service engineer.



# INSTALLATION

---

- 1 The Multi Moulder should be connected to a mains wall isolator.
- 2 When installing machines with 3 phase electrics check:-  
At the discharge end of the machine the upper belt surface should travel back into the machine - *see direction of arrows in photograph*.  
If belt direction is incorrect, change any two of the three phase wires in the plug and check travel again.

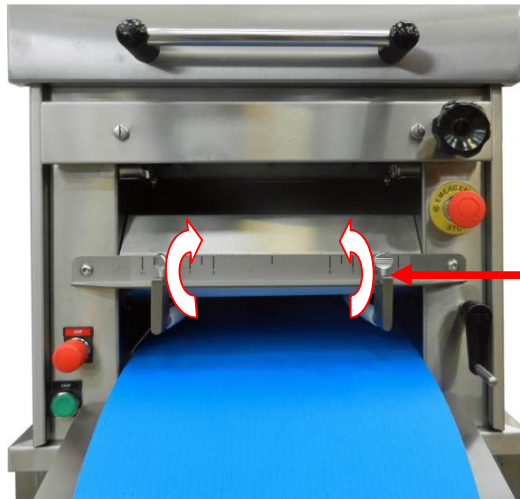

CHECK THE DIRECTION OF THE  
MOULDING BELT TRAVEL  
BEFORE COMMENCING  
PRODUCTION

- 3 Ensure machine is standing on a solid level floor

## 6.0 ISOLATION

---

To stop the multi moulder in an emergency, switch off at the wall isolator or at the machine's emergency stop button.(Twist to release)



**EMERGENCY STOP  
BUTTON**





## 7.0 CLEANING INSTRUCTIONS

**NOTE:- SWITCH OFF AND ISOLATE FROM THE MAINS SUPPLY BEFORE COMMENCING ANY CLEANING.**

### Daily cleaning

- 1 Scrape off any dough residue with a plastic scraper.
- 2 Wipe over perspex window on hopper with cloth dampened in approved sterilising solution and hot water.
- 3 Lift hopper / top sheet assembly (1)  
BEWARE THAT THE TOP SHEET ASSEMBLY IS HEAVY.



- 5 Lift out curling chain (5) and shake off any dough residue, then brush with a stiff nylon brush. **DO NOT WASH.**

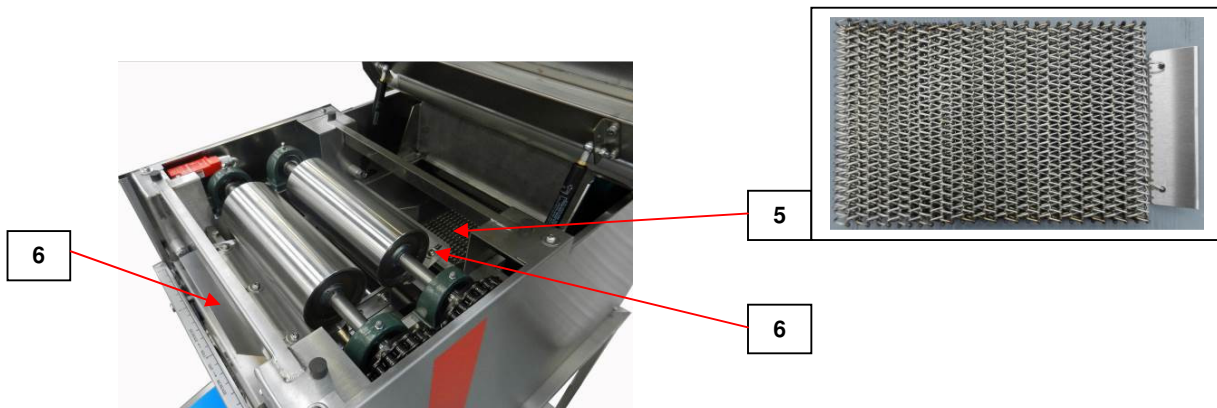

- 6 Replace chain.
- 7 Unclip and wipe scrapers (6) clean. **DO NOT WASH.** Smear edges with vegetable oil.

- 8 Scrape rollers with **plastic scraper** and remove any debris around roller edges.
- 9 Replace scrapers.
- 10 Unscrew rear panel nuts (7) using a spanner and remove rear panel (8). Clean belting on panel and remove any debris from around belt edges on machine.
- 11 Replace rear panel ensuring belting is correctly positioned before tightening nuts (7).

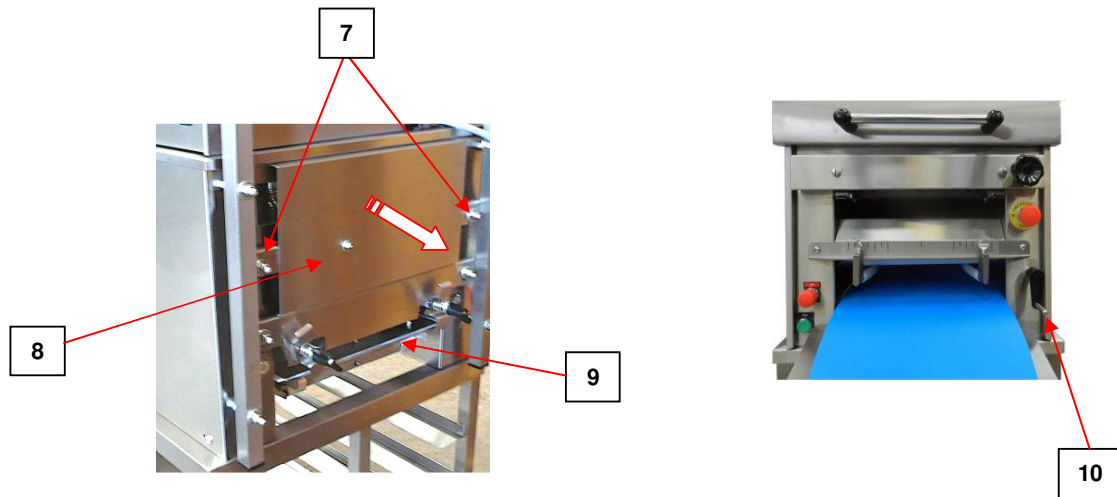

- 12 Remove pressure board (9) by winding handle (10) to move the board to its lowest position. Lift it out of its slots and slide the board out from the front of machine. Wash board in solution of sterilising solution and hot water. Dry thoroughly.
- 13 Close top assembly. BEWARE THIS IS HEAVY.
- 14 Scrape dough belt with a **plastic scraper**. **DO NOT USE A METAL SCRAPER.** The belt will have to be inched forward by turning the machine on and off to gain access to all parts of the surface.
- 15 Brush down external surfaces of machine and clean with sterilising solution and hot water. Pay particular attention to handles, levers and controls.

## 8.0 OPERATING CONDITIONS ---

For best results the Multi Moulder should be used on a solid, level floor and all operating and cleaning instructions should be followed meticulously.

## 9.0 GENERAL REMARKS REGARDING MACHINE MOULDING OF DOUGH.

The action of the MONO Multi Moulder consists of sheeting out, curling, and final moulding of the dough piece under pressure.

- Where dough is hand weighed prior to moulding it is important that as little flour as possible is used when handling. If floury dough pieces are fed into the machine, a poor mould will result giving a bad seal on the dough piece.
- **A brief rest of the dough piece is desirable** prior to moulding.
- If a stock of scaled dough pieces can be built up by using trays, or a large table, and then fed to the moulder starting with the first piece scaled, a decided improvement will be seen in the moulding.
- **Avoid allowing dough pieces to acquire a “skin”** as these could be difficult to mould.
- Attention to the setting of the moulder will be amply repaid in the superb results that this machine is capable of producing.

# 10.0 OPERATING INSTRUCTIONS

- A. Primary Adjustments
- B. Sheeting Gap
- C. Moulding pressure
- D. Starting

## A. PRIMARY ADJUSTMENTS

1. Adjust the hopper width to the size of dough piece to be used by adjusting the hopper cheeks evenly around the machine's centre line, using wing bolts (11).

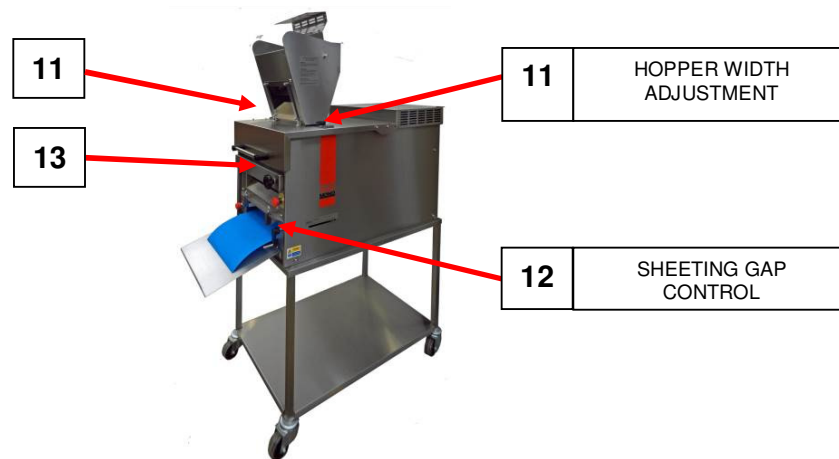

## B. SHEETING GAP.

The sheeting roll gap can be set to the required width using the adjusting handle (12). The setting of the sheeting roll gap is shown on the indicator (13) across the front cover.



**SHEETING ROLL GAP INDICATOR (13) ON FRONT OF MACHINE**

- If sheeting gap is too small-- this will result in **torn edges** to the dough pieces.
- If sheeting gap is too large-- this will result in **poor curling** of the dough pieces.

SUGGESTED SHEETING ROLL SETTINGS	
FINISHED LOAF	ROLL GAP SETTING
400 grms	No.5
800 grms	No.6

## C. MOULDING PRESSURE.

The moulding pressure applied to the dough pieces is adjusted by raising the pressure board (to increase pressure) or lowering it (to decrease pressure). This is done by adjusting the pressure board adjusting handle (10).

If the ends of the moulded piece are torn it indicates too great a pressure. Adjust accordingly by lowering the pressure board - turning the adjusting handle (10) anti-clockwise.

Insufficient pressure will result in a poor seal of the dough piece; rectify this by raising the pressure board by turning the adjusting handle (10) clockwise.

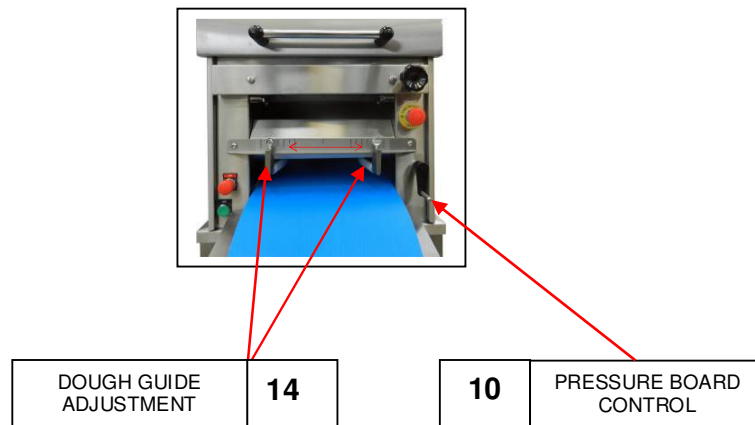

The pressure board dough guides (14) are adjusted by means of the guide clamps. The length of the dough piece required determines the width at which the dough guides are set. It should be noted that the dough guides and pressure board adjustments are relative to each other and should be adjusted accordingly.

## D. STARTING

Ensure moulder is set up and adequate tins and trays are available before starting  
Start moulder by pressing green start button.

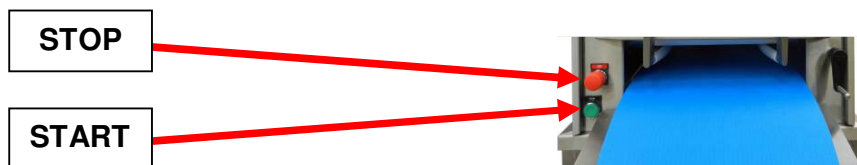

### **If moulder does not start check:-**

- 1 Check that the **power supply** is switched on.
- 2 Check that the **hopper door** is closed.
- 3 Check that all **safety interlocks** are properly engaged on the machine guards and covers.
- 4 Check that the **emergency stop** button is released (twist to release).

If machine still does not run call Mono Service Department.

# 11.0 MAINTENANCE

## IMPORTANT

**BEFORE REMOVING THE SIDE SHEETS OR MOTOR COVER, OR CARRYING OUT ANY CLEANING OR MAINTENANCE PROCEDURES, THE MACHINE MUST BE DISCONNECTED FROM THE MAINS SUPPLY.**

### MOULDING BELT ADJUSTMENT

- 1 The tension of the moulding belt rarely requires adjustment. Should the belt show signs of slipping, then the side sheets must be removed. After loosening the two bearing clamp bolts on each bearing (**16**), take up the slack by a small amount of equal adjustment of the belt tensioning bolts (**15**). Make sure the bearing bolts (**16**) are tightened after adjustment.

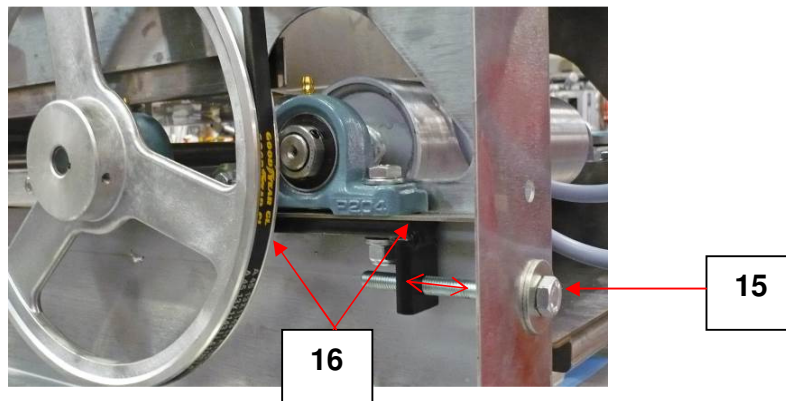

### EVERY THREE MONTHS

- 1 Once every three months the side sheets must be removed and the inside of the machine thoroughly brushed clean. The chain drive can also be given a light greasing if required.  
*NOTE: The bearings fitted to the machine will not normally require lubricating as they are sealed.*

### DRIVE BELT ADJUSTMENT

- 2 The drive belt from the motor rarely requires adjustment. If this becomes necessary, then remove the motor cover and adjust the motor in the desired direction by slackening off the four bolts (**17**) which secure the motor to its mounting. Tighten the bolts when the correct tension (**18**) is achieved.

**NOTE:- WHEN BELT TENSION (**18**) IS CORRECTLY ADJUSTED, THE MAXIMUM TOTAL MOVEMENT OF THE BELT AT THE CENTRE POINT OF ITS RUN SHOULD BE 20mm.**

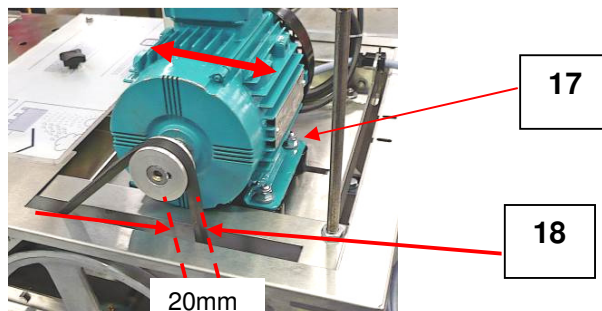

## 12.0 MOULDER WILL NOT START ---

If moulder does not start check:-

- 1 that the **power supply** is switched on.
- 2 that the **hopper door** is closed.
- 3 that all **safety interlocks** are properly engaged on the machine guards and covers.
- 4 that the **emergency stop** button is released. (Twist to release)

If the machine still does not run, call Mono Service Department.

## **13.0 SERVICE**

---

If a fault arises, please do not hesitate to contact the Customer Service Department, quoting the **machine serial number** on the silver information plate of the machine and on the front cover of this manual

### **MONO**

**Queensway  
Swansea West Industrial Estate  
Swansea.  
SA5 4EB  
UK**

**email: [spares@monoequip.com](mailto:spares@monoequip.com)  
Spares Tel. +44(0)1792 564039**

**Web site: [www.monoequip.com](http://www.monoequip.com)**

**Main Tel. 01792 561234  
Fax. 01792 561016**



## 14.0 SPARES

---

Tel. +44(0)1792 561234

Spares Tel. +44(0)1792 564039

Email:mono@monoequip.com

### GENERAL SPARES

### PART NUMBER TO ORDER

RETURN FLAP 129K03P03700

MOULDING BELT A900-22-041

PRESSURE BOARD FELT A900-22-025

SWING PLATE HANDLE P700-07-011

SWING PLATE INDICATOR ASSEMBLY 007-04-02600

*(MATCHED PAIR OF SCREWS AND NUTS)*

12 TOOTH SPROCKET 129K08D01600

18 TOOTH SPROCKET 129K08D01500

CONVEYOR AND TRANSMISSION BEARING A900-06-023

SHEETING ROLLER BEARINGS	A900-06-023
LIGHT DUTY CHAIN	A900-08-008
LIGHT DUTY CHAIN JOIN LINK	A900-08-013
HEAVY DUTY CHAIN	A900-08-010
HEAVY DUTY CHAIN JOIN LINK	A900-08-011
DRIVE CHAIN TENSIONER	007K08-D01100
DRIVE BELT	A900-21-025
<u>SHEETING ROLL SCRAPERS:-</u>	
FRONT	129K05D04200
REAR	129K05D04000
MOULDING FELT CLAMP	129K05D02500
MOULDING FELT HOOK	129K05D02600
OFFTAKE TRAY	169-02D04000

SCRAPER SPRING	129-05-01700
SHEETING ROLLER	129K05D01000
SHEETING ROLL ADJUSTING HANDLE	P700-07-006
LIVE ROLL	129K03D02400
<u>CURLING CHAIN ASSEMBLY:-</u>	
CHAIN	129K06D00100
BRACKET	129K06D00400
DRIVE PULLEY	129K08D02200
DRIVEN PULLEY	129K08D02100
DRIVE ROLLER	129K03D01900
HOCKEY STICK LEFT HAND	124K03D02900
HOCKEY STICK RIGHT HAND	124K03D02901
HOCKEY STICK COVER	A900-18-014
HOCKEY STICK NUT	A900-04-048
HOCKEY STICK SPRING	A900-19-009
HOCKEY STICK WING NUT	P700-04-005
MOULDING BELT GUIDE	129K03D00600
GAS STRUT (REPLACE IN PAIRS)	A900-29-016
BALL END JOINTS (FOR GAS STRUTS)	A900-29-017

IF IN ANY DOUBT - ASK

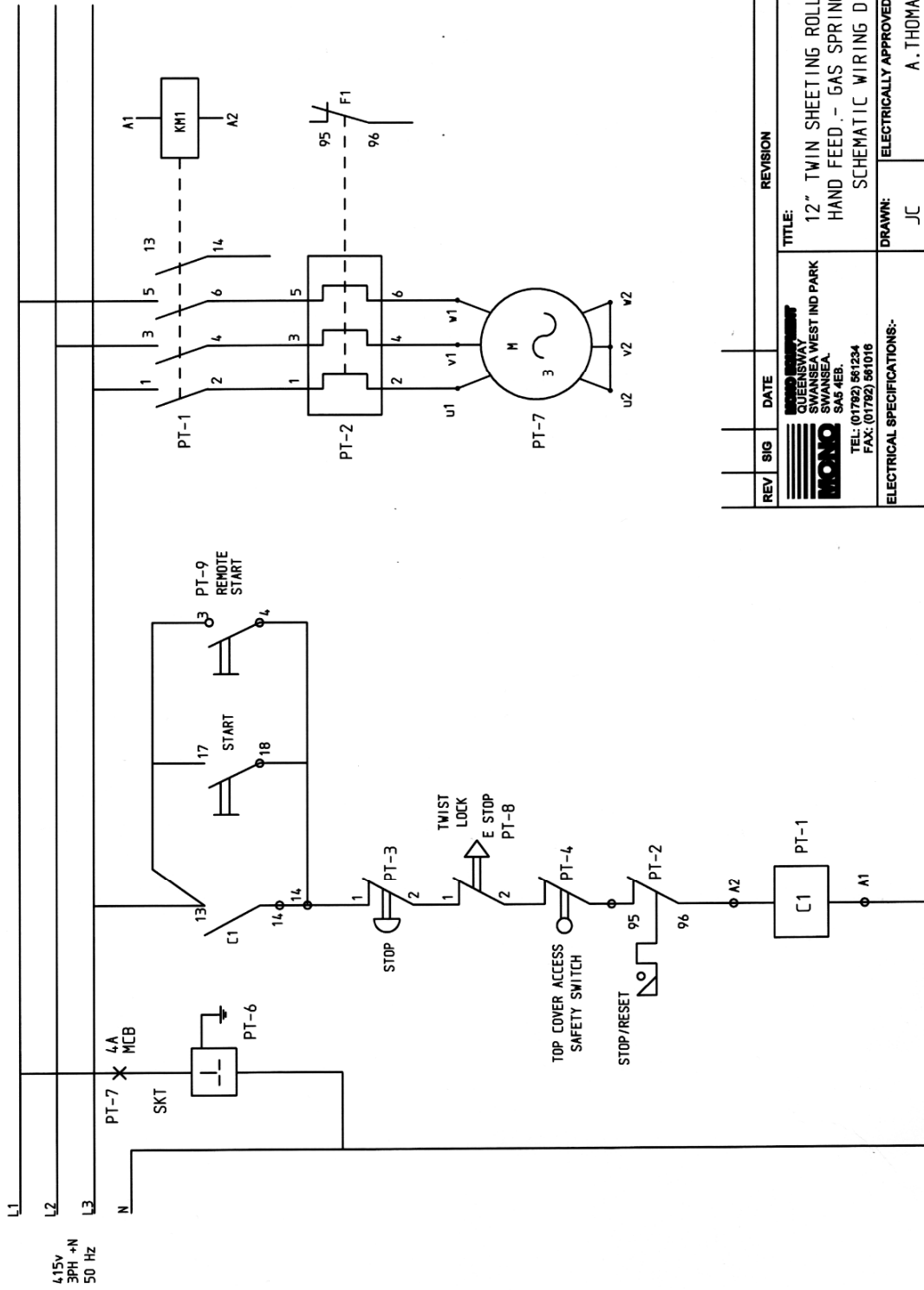

415v  
3PH +N  
50 Hz

COPYRIGHT © 1998 - THIS DESIGN/DRAWING IS THE PROPERTY OF MONO EQUIPMENT LTD. AND MUST NOT BE REPRODUCED, COPIED, NOR ITS CONTENTS DIVULGED WITHOUT PRIOR WRITTEN PERMISSION.

REV	SIG	DATE	REVISION	ECN NO.
<p><b>MONO EQUIPMENT LTD.</b>                  QUEENSWAY                  SWANSEA WEST IND PARK                  SWANSEA,                  SA5 4EB.                  TEL: (01792) 981234                  FAX: (01792) 981016</p>				
ELECTRICAL SPECIFICATIONS:-			TITLE:	
415V 3PH N 50HZ			12" TWIN SHEETING ROLL MOULDER HAND FEED - GAS SPRING ACCESS SCHEMATIC WIRING DIAGRAM	
ELECTRICALLY APPROVED BY:-			DRAWN:	
A. THOMAS			JC	
DATE:			DATE:	
9-1-17			9-1-17	
DRAWING NO.			DRAWING NO.	
169E25-31000			169E25-31000	
REV:			REV:	
-			-	

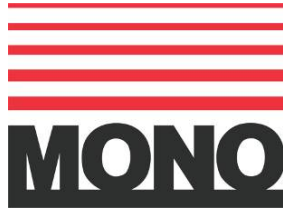

**MONO Equipment**  
Queensway,  
Swansea West Industrial Park,  
Swansea,  
SA5 4EB  
UK

Tel. +44(0)1792 561234  
Fax. 01792 561016

Spares Tel. +44(0)1792 564039

Email:mono@monoequip.com

**[www.monoequip.com](http://www.monoequip.com)**

As it is our policy to improve our machines continuously, we reserve the right to change specifications without prior notice.

□ **DISPOSAL**

**CARE SHOULD BE TAKEN WHEN THE MACHINE COMES TO THE END OF ITS WORKING LIFE. ALL PARTS SHOULD BE DISPOSED OF IN THE APPROPRIATE PLACE, EITHER BY RECYCLING OR OTHER MEANS OF DISPOSAL THAT COMPLIES WITH LOCAL REGULATIONS. (IN UK, ENVIRONMENTAL PROTECTION ACT 1990 APPLIES)**